



Welcome To Your City Commission Meeting - Please turn off or silence all cell phones during the commission meeting.
Meetings are televised everyday on Channel 2 at 7 p.m. and midnight

Call to Order – Pledge of Allegiance Followed by Silent Meditation

OLD BUSINESS:

Consideration of Previous Meeting Minutes:

1. Minutes from July 24, 2018 Regular Meeting & August 7, 2018 Special Meeting **Action:** Motion (pg. 2)

Second Consideration Ordinance:

2. Second Consideration Ordinance No. 8082 Demolition Assessments **Action:** Roll Call Vote (pg. 7)
3. Second Consideration Ordinance No. 8083 Nuisance Assessments **Action:** Roll Call Vote (pg. 10)

NEW BUSINESS:

Citizen Participation: (*i.e. Items not listed on the agenda or receipt of petitions- Please state your name and address*)

General Items:

4. Mosquito Program Discussion (pg. 15)
5. Public Hearing 2019 Budget (pg. 16)
 - a. Open Public Hearing **Action:** Motion
 - i. Present 2019 Budget
 - b. Close Public Hearing **Action:** Motion
 - c. Adopt the 2019 Budget **Action:** Motion
 - d. Adopt Housing Budget (Planters II) Resolution B-2204 **Action:** Motion
6. Annual Approval of the Edward Byrne Grant **Action:** Motion (pg. 27)

Bids, Contracts and Agreements:

7. Consider Proposals for Replacement of Cody Park Playground Equipment **Action:** Motion (pg. 30)
8. Consider Bids for PAC HVAC Phase 3 **Action:** Motion (pg. 38)
9. Consider Sole Source Contract for City Hall HVAC System Upgrade and Repair **Action:** Motion (pg. 40)
10. Consider Bids for WPC Tandem Axle Dump Truck **Action:** Motion (pg. 43)
11. Consider Contract for Website Redesign **Action:** Motion (pg. 84)

First Consideration Ordinance:

12. First Consideration Charter Ordinance Transient Guest Tax **Action:** Consensus (pg. 131)
13. First Consideration Ordinance Uniform Public Offense Code 2018 **Action:** Consensus (pg. 139)
14. First Consideration Ordinance Standard Traffic Ordinance 2018 **Action:** Consensus (pg.146)
15. First Consideration Ordinance Intersection Traffic Control Devices 2018 **Action:** Consensus (pg. 150)

Consent Agenda: Claims for July 21, 2018 through August 3, 2018 in the amount of \$2,630,862.20 ; Net amount for Pay #16 effective August 3, 2018 in the amount of \$338,157.51 ; (No Police & Fire Pension). **Action:** Motion

Adjourn: **Action:** Motion



CALL TO ORDER - The Governing Body met in regular session and the following commission members were present: Mayor Mark Preisinger, Mayor Pro-Tem Jermaine Wilson, Commissioners Nancy Bauder and Myron J. (Mike) Griswold; not present: Commissioner Larry Dedeke.

Others present: City Manager Paul Kramer, Assistant City Manager Taylour Tedder, Public Works Director Mike McDonald, Operations Superintendent Curtis Marks, Solid Waste Foreman Steve King, Finance Director Ruby Maline, Public Information Officer Melissa Bower, City Attorney David E. Waters and City Clerk Carla K. Williamson.

Mayor Mark Preisinger opened the meeting with the pledge of allegiance followed by silent meditation.

PROCLAMATIONS:

National Farmer's Market Week

Patty Scharinger was present to receive the proclamation on behalf of the Leavenworth Farmer's Market.

OLD BUSINESS:

Consideration of Previous Meeting Minutes:

Commissioner Bauder moved to approve the minutes from the July 10, 2018 regular meeting as presented. Commissioner Wilson seconded the motion and was unanimously approved. The Mayor declared the motion carried 4-0.

NEW BUSINESS:

Citizen Participation:

Charlsey Filbert - 205 Topeka Ave
Melissa Tinsley - 1619 6th Ave
Brittan Young-Henderson – 320 Vine Street

Ms. Filbert addressed the Commission with these items:

- Aware there is an upcoming study session on mosquito spraying
- Cited a recent article in the Leavenworth Times and West Nile Virus from KDHE
- 2015 was the last case of West Nile Virus in Leavenworth County
- Provided various statistics on West Nile Virus
- Asked how requests for spraying are tracked

- Asked what steps are taken if someone is in violation of stagnant water as described in Chapter 54 of the City Code
- Would like the City to publicly disclose the cost of spraying each year
- Just because someone is against spraying does not mean they are not pro-mosquito
- Has heard there has been trapping and testing of mosquitos on Fort Leavenworth

Mayor stated that the City Manager has been in contact with a top entomologist from Kansas State University.

City Manager Kramer stated that he has been in contact with Dr. Jeff Wentworth at Kansas State University and he or someone from his team will be here in August to attend a Study Session regarding the topic of mosquitoes.

Ramona Price - 92 Woodmor Court

- Dog was picked up for running at large
- Not his first offense for running at large
- Dog lunged at officer when he was picked up
- Trying to classify as dangerous dog
- Has asked Animal Control if she can have an animal behaviorist evaluate her dog
- Was told by Animal Control that the Lt. will have to decide if they will allow third party evaluation of the dog
- Has been nine days without her dog
- Court date is this Thursday

Mayor Preisinger directed City Manager to work with Animal Control and Ms. Price.

City Attorney Waters is not aware of any requirement that the City allow outside evaluation. The city prosecutor makes the determination if charges are brought forward. The Judge makes the determination if the dog is deemed dangerous or not.

Ms. Price asked about why there are no ordinances against cats and stated that her dog had not bitten anyone and therefore should not be deemed dangerous.

City Attorney Waters stated that he is not aware of any cities that have dangerous cat ordinance. Mr. Waters read the ordinance from the City Code of Ordinances and the ordinance states *show of aggression*. It does not state that it is required that the animal has bitten to be deemed dangerous.

Bids, Contracts and Agreements:

Consideration of the 2018 Sanitary Sewer Inflow and Infiltration (I & I) Contract with Linaweaver Construction – Public Works Director Mike McDonald presented for consideration the bids for the 2018 Sanitary Sewer I & I Project. Staff recommends approval of the low base bid and alternate 1 bid received from Linaweaver Construction in the amount not to exceed \$475,564.00. Bids were opened on July 18, 2018 and were as follows:

Bidder	City	Base Bid	Alternate 1 Bid	Total Bid
Lexeco Inc.	Leavenworth	\$440,504.00	\$246,525.00	\$687,029.00
Linaweaver Construction	Lansing	\$295,960.00	\$179,604.00	\$475,564.00
Westland Construction	Basehor	\$332,940.00	\$225,045.00	\$557,985.00
Engineer's Base Bid Estimate		\$477,410.00		

John Will from Linaweaver Construction addressed the Commission to answer some questions on the bidding process.

Commissioner Bauder moved to approve the low base bid and alternate 1 bid received from Linaweaver Construction in the amount not to exceed \$475,564.00 for the 2018 Sanitary Sewer Inflow and Infiltration Project. Commissioner Wilson seconded the motion and was unanimously approved. The Mayor declared the motion carried 4-0.

Consider Proposals for Solid Waste Disposal Services – Public Works Director Mike McDonald presented for consideration proposals for solid waste disposal services. Due to a rise in fees by Leavenworth County for use of the County transfer station from \$35.00 per ton to \$45.00 per ton in 2019 Staff revisited the costs and benefits of hauling the solid waste directly to area landfills. Bids were solicited from several locations. Staff evaluated the bids and found the bid from Waste Management to be the best option. Staff recommends approval of the bid by Waste Management for at least one year after a review and approval of the contract by the City Attorney. Approval of the bid will allow the City Manager to sign the contract after it has been finalized. Below are the responses for a one-year contract:

Company	Response
Hamm Landfill	*MSW - \$30.25/Ton; Sludge \$30.25/Ton; Grit/Special Waste \$15.00/Ton for all contract periods
Waste Management	All waste \$24.00/Ton for 1-year, \$23.00/Ton for 3-year; \$22.00/Ton for 5-Year; subject to possible 3% /year increase
Leavenworth County	Verbal discussion confirmed the \$45.00/Ton tipping fee. No written response was received
Atchison County	No response

**MSW = Municipal Solid Waste*

Scott Cornell with Waste Management addressed the Commission and answered questions related to their operation.

Commissioner Griswold moved to approve the bid by Waste Management for at least one year at a cost of \$24.00 per ton. Commissioner Wilson seconded the motion and was unanimously approved. The Mayor declared the motion carried 4-0.

First Consideration Ordinances:

First Consideration Ordinance – Demolition Assessments – City Clerk Carla Williamson presented for first consideration an ordinance levying special assessments for the City’s cost to demolish or prepare for demolition of five properties.

There was a consensus by the City Commission to place on first consideration.

First Consideration Ordinance – Nuisance Assessments – City Clerk Carla Williamson presented for first consideration an ordinance levying special assessments for the cost and administrative fees for lot cleanup and or mowing.

There was a consensus by the City Commission to place on first consideration.

CONSENT AGENDA:

Commissioner Griswold moved to approve claims for July 7, 2018 through July 20, 2018 in the amount of \$682,240.58; Net amount for Pay #15 effective July 20, 2018 in the amount of \$362,134.01 (Includes Police & Fire Pension in the amount of \$11,572.36). Commissioner Wilson seconded the motion and was unanimously approved. The Mayor declared the motion carried 4-0.

Other:

Adjourn:

Commissioner Bauder moved to adjourn the meeting. Commissioner Wilson seconded the motion and was unanimously approved. The Mayor declared the motion carried and the meeting adjourned.

Time Meeting Adjourned 8:04 p.m.

Minutes taken by City Clerk Carla K. Williamson, CMC



The City Commission met for a Study Session with the following members present: Mayor Mark Preisinger, Mayor Pro-Tem Jermaine Wilson, Commissioners Nancy Bauder and Larry Dedeke. Commissioner Myron J. (Mike) Griswold attended via telephone.

Others Present: City Manager Paul Kramer, Assistant City Manager Taylour Tedder, Finance Director Ruby Maline, Public Information Officer Melissa Bower and City Clerk Carla K. Williamson.

The Governing Body signed the consent for the special meeting written waiver notice.

Mayor Preisinger called for a motion to open the special meeting.

Commissioner Dedeke moved to open a Special Meeting. Commissioner Bauder seconded the motion and was unanimously approved. The Mayor declared the motion carried 5-0.

Consider the Purchase of 301 Delaware Street—City Manager Paul Kramer presented for consideration the purchase of 301 Delaware Street from Triple R Properties LLC in the amount of \$52,500.00 which includes the price of the property and realtor commission fees. Mr. Kramer discussed various properties that have been purchased in the past to spur economic development. If the Commission approves the purchase Staff will move forward with demolition and regrading of the site.

Commissioner Bauder moved to approve the purchase of 301 Delaware Street from Triple R. Properties LLC in the amount of \$52,500.00 and authorize the Mayor to execute all documents related to the purchase. Commissioner Bauder seconded the motion and was unanimously approved. The Mayor declared the motion carried 5-0.

Mayor's Appointment- Library Board—Mayor Preisinger moved to appoint to the Library Board, Lisa Weakley to an unexpired term ending April 30, 2019. Commissioner Dedeke seconded the motion and was unanimously approved. The Mayor declared the motion carried 5-0.

Comments:

Commissioner Bauder

Visited the apartments at Hughes Road recently and they are beautiful and the residents are very happy.

City Manager Kramer

Mr. Kramer stated that a representative from Kansas State entomology department will be at the City Commission Meeting on Tuesday August 14 unless they have any schedule changes.

Adjourn:

Commissioner Dedeke moved to adjourn the meeting. Commissioner Bauder seconded the motion and was unanimously approved. The Mayor Pro-Tem declared the motion carried and the meeting adjourned.

Meeting adjourned at 7:53 p.m.

Minutes taken by City Clerk Carla K. Williamson

**POLICY REPORT
SECOND CONSIDERATION ORDINANCE
ORDINANCE TO LEVY SPECIAL ASSESSMENTS FOR
DEMOLITION COSTS**

AUGUST 14, 2018

Prepared by:

Reviewed by:



Carla K. Williamson, CMC
City Clerk

for Paul Kramer
City Manager

Background:

At the July 24, 2018 meeting the City Commission discussed and placed on first consideration

“AN ORDINANCE LEVYING AND ASSESSING SPECIAL ASSESSMENTS FOR CERTAIN LOTS, PIECES AND TRACTS OF LAND IN THE CITY OF LEAVENWORTH, LEAVENWORTH COUNTY, KANSAS, FOR THE PURPOSE OF PAYING THE COSTS OF DEMOLITION AND PRESCRIBING FOR PAYMENT AND COLLECTION OF SAID ASSESSMENTS.”

At the time of this Policy Report, no payments have been received. Any payments received up to 5:00 P.M. on August 14, 2018 will be removed from the ordinance.

Action:

Ordinance No. 8082 is now presented for second consideration and requires a roll call vote.

(Published in the Leavenworth Times on August 17, 2018)

ORDINANCE NO. 8082

AN ORDINANCE LEVYING AND ASSESSING SPECIAL ASSESSMENTS FOR CERTAIN LOTS, PIECES AND TRACTS OF LAND IN THE CITY OF LEAVENWORTH, LEAVENWORTH COUNTY, KANSAS, FOR THE PURPOSE OF PAYING THE COSTS OF DEMOLITION AND PRESCRIBING FOR PAYMENT AND COLLECTION OF SAID ASSESSMENTS.

WHEREAS, by due and legal proceedings heretofore carried into effect by the City of Leavenworth, Kansas, certain unsafe structures have been abated, and

WHEREAS, several lots pieces, parcels and tracts of land hereinafter set forth are legally liable to pay the costs or proportionate costs hereof as provided by the Code of the City of Leavenworth, Kansas, and

WHEREAS, the cost of such abatement has been ascertained as provided by law and fixed and distributed and apportioned as in this ordinance set forth.

NOW, THEREFORE, BE IT ORDAINED BY THE GOVERNING BODY OF THE CITY OF LEAVENWORTH, KANSAS:

Section 1. That for the purpose of paying the costs to demolish unsafe structures in the City of Leavenworth, Kansas, there shall be and hereby is apportioned to be levied and assessed on and against certain lots, pieces, parcels and tracts of land liable; therefore, special assessments hereinafter set out in such amounts, as are set out as follows:

Property Owner	Street Address	Legal Address	Demolition Cost
Justine Alexander	116 Ottawa St	Lot 17, 18 and 19, in Block 12, in Leavenworth City Proper, Leavenworth County, Kansas	\$10,300.00
Brian K & Julia Rose Visocky	709 Oak St	E32' of Lot 4, Block 21, Latta's Addition, a subdivision in the City of Leavenworth Leavenworth County, Kansas	\$10,850.00
Pamela A Barden	913 Pawnee St	Lots 10 and 11, Block 34, Macaulay's First Addition to the City of Leavenworth, Leavenworth County, Kansas	\$3,590.00
Swift Holdings, LLC	119-121 Kickapoo St	The North 85.00 feet of the West 20.83 feet of Lot 15, and the North 85 feet of Lot 16, Block 12, Leavenworth City Proper, a subdivision in the City of Leavenworth, Leavenworth County, Kansas	\$1,550.00
William and Kristina Russell	1214 Pottawatomie St	Lot 12, Herrig's Subdivision of Block 89, Central Subdivision, in the City of Leavenworth, Leavenworth County, Kansas	\$1,600.00
		Total	\$27,890.00

Section 2. Such amounts so levied and assessed are set forth in Section 1 of this ordinance, shall be due and payable from and after publication of this ordinance, and the City Clerk shall certify same to the County Clerk for collection as other special assessments are collected and such amounts so certified shall be placed on the tax rolls and collected as special assessments.

Section 3. This Ordinance shall take effect and be in force from and after its passage, approval, and publication in the official city newspaper.

PASSED and APPROVED by the Governing Body on this 14th day of August, 2018.

Mark Preisinger, Mayor

{SEAL}

ATTEST:

Carla K. Williamson CMC, City Clerk

**POLICY REPORT
SECOND CONSIDERATION ORDINANCE
ORDINANCE TO LEVY SPECIAL ASSESSMENTS FOR
NUISANCE ABATEMENT COSTS**

AUGUST 14, 2018

Prepared by:



Carla K. Williamson, CMC
City Clerk

Reviewed by:

for Paul Kramer
City Manager

Background:

At the July 24, 2018 meeting the City Commission discussed and placed on first consideration

“AN ORDINANCE LEVYING AND ASSESSING SPECIAL ASSESSMENTS FOR CERTAIN LOTS, PIECES AND TRACTS OF LAND IN THE CITY OF LEAVENWORTH, LEAVENWORTH COUNTY, KANSAS, FOR THE PURPOSE OF PAYING THE COSTS OF ABATEMENT OF NUISANCES AND PRESCRIBING FOR PAYMENT AND COLLECTION OF SAID ASSESSMENTS.”

Since the July 24th meeting payments have been received on several properties and those assessments have been removed. Any additional payments received up to 5:00 P.M. on August 14, 2018 will be removed from the list.

Action:

Ordinance No. 8083 is now presented for second consideration and requires a roll call vote.

(Published in the Leavenworth Times on August 17, 2018)

ORDINANCE NO. 8083

AN ORDINANCE LEVYING AND ASSESSING SPECIAL ASSESSMENTS FOR CERTAIN LOTS, PIECES AND TRACTS OF LAND IN THE CITY OF LEAVENWORTH, LEAVENWORTH COUNTY, KANSAS, FOR THE PURPOSE OF PAYING THE COSTS OF ABATEMENT OF NUISANCES AND PRESCRIBING FOR PAYMENT AND COLLECTION OF SAID ASSESSMENTS.

WHEREAS, by due and legal proceedings heretofore carried into effect by the City of Leavenworth, Kansas, certain nuisances have been abated, and

WHEREAS, several lots pieces, parcels and tracts of land hereinafter set forth are legally liable to pay the costs or proportionate costs hereof as provided by the Code of the City of Leavenworth, Kansas, and

WHEREAS, the cost of such abatement has been ascertained as provided by law and fixed and distributed and apportioned as in this ordinance set forth.

NOW, THEREFORE, BE IT ORDAINED BY THE GOVERNING BODY OF THE CITY OF LEAVENWORTH, KANSAS:

Section 1. That for the purpose of paying the costs of abatement of nuisances in the City of Leavenworth, Kansas, there shall be and hereby is apportioned to be levied and assessed on and against several lots, pieces, parcels and tracts of land liable; therefore, special assessments hereinafter set out in such amounts, as are set out as follows:

ATTACHED GRASS AND WEEDS NUISANCE ASSESSMENTS – EXHIBIT A

Section 2. Such amounts so levied and assessed are set forth in Section 1 of this ordinance, shall be due and payable from and after publication of this ordinance, and the City Clerk shall certify same to the County Clerk for collection as other special assessments are collected and such amounts so certified shall be placed on the tax rolls and collected as special assessments.

Section 3. This Ordinance shall take effect and be in force from and after its passage, approval, and publication in the official city newspaper.

PASSED and APPROVED by the Governing Body on this 14th day of August, 2018.

Mark Preisinger, Mayor

{SEAL}

ATTEST:

Carla K. Williamson CMC, City Clerk

Property Owner	Property Address	CAMA	Legal Description	Billed Amt
DWIRE, TERESA	1028 9TH AVENUE	0773504009009000	BENZ'S SUBDIVISION, BLOCK 2, Lot 4	\$118.24
SECRETARY OF VETERAN'S AFFAIRS	1602 PAWNEE STREET	0782701003029000	BESETTE SUBDIVISION, BLOCK 2, Lot 8	\$660.97
STANDIFER, BIANCIA	222 DAKOTA STREET	0772502008006000	BRIDGEPORT SUBDIVISION, S25, T08, R22E, BLOCK 2, Lot 18	\$2,137.04
JACKSON, WINNIE	1424 6TH AVENUE	0773504025019000	BUETTINGERS 2ND SUB, BLOCK 1, N32'LT 5 & S1/2 LT 6	\$125.00
CARLSON, MICHAEL D & DANNIELLAJO G BASS	1411 6TH AVENUE	0773504027006000	BUETTINGERS 2ND SUB, BLOCK 2, Lot 8	\$267.91
H&P DEVELOPMENT LLC	2101 2ND AVENUE	1010103002004000	BYINGTONS SUB, N145' BLK 5 EXC E180' BYINGTONS SUB & N145' BLK 16 JOHNSONS SUB (SCALED)	\$2,100.00
WESLEY, MONTARIAL A & LAKISHA	213 SOUTH 10TH STREET	0773502010005000	CENTRAL SUBDIVISION, BLOCK 15, Lot 26	\$2,679.60
DUCKWORTH, HARLAN J & HOOTEN, SHARLEE S	1002 CHEROKEE STREET	0773502009016000	CENTRAL SUBDIVISION, BLOCK 26, E38'LTS 1-4	\$120.00
LIS, KEVIN C & PATRICIA A	209 SOUTH 12TH STREET	0773502008008000	CENTRAL SUBDIVISION, BLOCK 29, Lot 5 - 6	\$115.50
NEELAND, MARYANN	1311 CHEROKEE STREET	0773502018002000	CENTRAL SUBDIVISION, BLOCK 51, LTS 4 & 5 & E27' LT 6	\$135.73
NEXIA HOLDINGS, INC	431 NORTH 12TH STREET	0772603016001000	CENTRAL SUBDIVISION, S26, T08, R22E, BLOCK 88, TR BLK 88 CENTRAL SUB; BEG INTER POTTAWATOMIE ST & 12TH ST; S27', W115', NWLY37.3', E143' TO POB & ABAN RR ROW ADJ	\$1,428.96
WACKER, THOMAS E	854 SHERMAN AVENUE	0773501014002000	CENTRAL SUBDIVISION, S35, T08, R22E, BLOCK 13, PT BLK 13; BEG W69' FROM NE COR SE60'(S), SW43', NW75' (S), E28' TO POB (SCALED)	\$2,144.56
OUR OCEAN VIEW LLC	208 SOUTH 10TH STREET	0773502009017000	CENTRAL SUBDIVISION, S35, T08, R22E, BLOCK 26, Lot 5 - 6	\$275.00
WEBSTER, RODNEY W	303 SPRUCE STREET	0773602048001010	CLARK & REES ADDITION, BLOCK 18, N92' LT 1 & N92' OF E5' LT 2	\$150.00
WILLIAMSON, ANDY T L	616 SPRUCE STREET	0773602042012000	CLARK & REES ADDITION, BLOCK 30, Lot 12, (SCALED)	\$1,546.95
CHISHTI REAL ESTATE INC	619 OAK STREET	0773602022004000	CLARK & REES ADDITION, BLOCK 33, Lot 5	\$2,562.25
HUDSPETH, CHADWICK G	625 OAK STREET	0773602022006000	CLARK & REES ADDITION, BLOCK 33, Lot 7	\$1,939.26
PURSEL, MATTHEW ROSS & ANGELICA B LIS, KELLEY A	607 OAK STREET	0773602022003000	CLARK & REES ADDITION, BLOCK 33, W5'LT 3 & ALL LT 4	\$250.00
LIS, KELLEY A	717 OLIVE STREET	0773602040002000	CLARK & REES ADDITION, BLOCK 38, W20'LT 4 & E15'LT 5	\$268.77
CARLYSLE, BETTY & BILLY	934 OTTAWA STREET	0772603105008000	COCHRAN & MULLIGAN'S SUB , BLOCK 14 , LT 39 COCHRAN & MULLIGAN'S SUB & LT 29 EWING, ROELOFSON & CO SUB (SCALED).	\$370.22
SMITH, AMY R	926 POTTAWATOMIE STREET	0772603108007000	COCHRAN & MULLIGAN'S SUB , BLOCK 24 , Lot 38 - 39	\$390.50
MELONE, MARYLYN	1011 COLUMBIA AVENUE	0773504011004000	DAVIS, JAMES, ADD, BLOCK 6, Lot 10	\$125.00
ANDERSON, CHERYL	722 KICKAPOO STREET	0772604102019000	DAY & MACAULAY'S SUB, BLOCK 100, Lot 10 - 11	\$391.40
DEVELOPMENT INC	735 METROPOLITAN AVENUE	0772601403004000	DAY & MACAULAY'S SUB, BLOCK 104, S75'LTS 27 & 28	\$117.24
CLARK, MARIA L & CLARK, MEGAN N	907 NORTH BROADWAY STREET	0772601310010000	DAY & MACAULAY'S SUB, BLOCK 108, Lot 4	\$124.14
LD DEVELOPMENT LLC	801 NORTH BROADWAY STREET	0772604201001000	DAY & MACAULAY'S SUB, BLOCK 109, ACRES 1.8	\$439.78
CARIGLIO, CHRISTINA M	604 CONGRESS STREET	0773603005008000	DAY'S SUBDIVISION , BLOCK 3 , W53' OF S30'LT 9 & W53'LT 10.	\$111.36
SANTEE, DAVID ROY	615 PROSPECT STREET	0773603039004000	DAY'S SUBDIVISION, BLOCK 18, W1/2 LT 6 & ALL LT 7	\$2,737.98
VOSSSELER, THOMAS W JR	622 OHIO STREET	0773603039009000	DAY'S SUBDIVISION, BLOCK 18, W40'LTS 11-13	\$381.22
ANDINO, ROBERT G	916 4TH AVENUE	0773603005011000	DAY'S SUBDIVISION, BLOCK 3, Lot 7	\$117.37
NELSON, GARY A & TONIA L	1020 2ND AVENUE	0773603010013000	DAY'S SUBDIVISION, BLOCK 8, Lot 23	\$116.64
CAMMACK, CURTIS W	617 MIDDLE STREET	0773603024005000	DAY'S SUBDIVISION, S36, T08, R22E, BLOCK 15, Lot 6 - 7	\$2,855.62
BRUNDY, JOSEPH W JR & DOROTHY E	1416 4TH AVENUE	0773603040011000	DAY'S SUBDIVISION, S36, T08, R22E, BLOCK 19, Lot 19	\$605.00
HIATT, DONALD L	611 NORTH 8TH STREET	0772604208025000	EWING, ROELOFSON & CO., BLOCK 13, LTS 5 & 6 & S28.5'LT 7	\$2,645.18
DUREE, BETTY J	1028 POTTAWATOMIE STREE	0772603107012000	EWING, ROELOFSON & CO., BLOCK 4, LT 29 & W18'LT 30	\$1,035.36
SALYERS, VICTORIA A	1117 POTTAWATOMIE STREET	0772603015003000	EWING, ROELOFSON & CO., BLOCK 8, LOT 12 Total	\$1,029.56
THE ZENITH SHOP	829 KICKAPOO STREET	0772604208009000	EWING, ROELOFSON & CO., S26, T08, R22E, BLOCK 13, LT 19 LESS TR BEG NE COR S63', W8.4', NE63', E1.2' TO POB	\$2,182.56
CAMPBELL, MISTY D	917 KICKAPOO STREET	0772604209004000	EWING, ROELOFSON & CO., S26, T08, R22E, BLOCK 14, Lot 13 - 14.	\$394.76
KOPP, MICHAEL E & KATHY ANN	503 NORTH 11TH STREET	0772603014018000	EWING, ROELOFSON & CO., S26, T08, R22E, BLOCK 7, Lot 1 - 2	\$125.00
WILLIAMS, CHARLES F JR & LILLIAN A	1129 OSAGE STREET	0772603021003000	EWING, ROELOFSON & CO., S26, T08, R22E, BLOCK 9, LTS 21-28 & ABAN RR ROW ADJ	\$1,215.97
JENG, SANDRA Y	209 ELM STREET	0773604005003000	FACKLERS ADDITION, BLOCK 11, Lot 3	\$301.02
COATES, AARON RYAN	418 LINN STREET	0773603030011000	FACKLERS ADDITION, BLOCK 23, Lot 11	\$119.27
R & M INVESTMENT GROUP LLC	500 ELM STREET	0773603026009000	FACKLERS ADDITION, BLOCK 28, Lot 13 - 16	\$2,100.00
SENTMAN, SAMUEL L	511 VINE STREET	0773603026006000	FACKLERS ADDITION, BLOCK 28, Lot 6, (SCALED)	\$814.72
ADAMS, RYAN M & MILLS, KIRA A	508 MAPLE STREET	0773603033011000	FACKLERS ADDITION, S36, T08, R22E, BLOCK 30, LTS 13 & 14 EXC E10' LT 14	\$145.16
RICH, SHARI A	1916 MONTEZUMA AVENUE	1010201016022000	FENNS BROADWAY SUB, BLOCK 1, Lot 25&26	\$1,313.17

Property Owner	Property Address	CAMA	Legal Description	Billed Amt
MINOR, EDWIN A & KATHY A	1015 NORTH 14TH STREET	0782701005009000	FENN'S FAIRGROUND SUB, BLOCK 5, Lot 37 - 41	\$1,255.71
CONREX RESIDENTIAL PROPERTY GROUP 2013-1	1329 CHEYENNE STREET	0782701008001000	FENN'S FAIRGROUND SUB, BLOCK 6, E19'LT 42 & ALL LT 43 & W1/2 VAC N/S ALLEY ADJ	\$300.00
QUIGLEY, DEREK R	1331 CHEYENNE STREET	0782701008002000	FENN'S FAIRGROUND SUB, BLOCK 6, LTS 40-41 & W5'LT 42	\$150.00
LYONS,ETHAN LOREN & MIKALLIA	1010 NORTH 14TH STREET	0782701008009000	FENN'S FAIRGROUND SUB, BLOCK 6, N1/2 LT 3 & ALL LTS 4&5	\$131.08
HANSEN, CORAL L	1400 KIOWA STREET	0782704003017010	FENN'S FAIRGROUND SUB, S27, T08, R22E, BLOCK 1, Lot 33 - 35	\$141.33
H&P DEVELOPMENT LLC	800 NORTH 17TH STREET	0782704005001000	FOWLER'S ADDITION, LOT 4, ACRES 2.21	\$1,950.00
PAYNE-HOWARD, LULA MAE	1720 SHAWNEE STREET	0782704018011000	GIST SURVEY, PT GIST SURVEY IN SE1/4;BEG 231'E & 30'N SW COR SE1/4, N110',E100',S110',W100'TO POB	\$946.00
H&P DEVELOPMENT LLC	1131 METROPOLITAN AVENUE	0772602004009000	GIST SURVEY, S26, T08, R22E, PT GIST SURVEY IN NW1/4;BEG SE COR INTER METRO AVE & 12TH ST, E50.1', S154.1', W50', N152' TO POB	\$1,054.29
HARVEST ENTERPRISES LLC	1051 NORTH 16TH STREET	0782701003001000	GIST SURVEY, S27, T08, R22E, ACRES 3.8, PT GIST SURVEY IN NE1/4; BEG 90'N INTER PAWNEE ST & 16TH ST; W650'(S), N290'(S), SELY660'(S), S190'(S) TO POB (SCALED)	\$425.00
ADAMS, WILLIAM CASEY	3000 SHRINE PARK ROAD	1011101002009000	GODDARD'S SUBDIVISION, Lot 44	\$451.96
PAJAK, KELLY	1000 SHERMAN AVENUE	0773502012012000	HALDERMAN'S SUBDIVISION, S35, T08, R22E, BLOCK 25, PT LTS 6-12 & VAC ALLEY BEG SE COR LT 11, N94.17', W136.5', S45'(S), SW20'(S), S125', NE170'(S) TO POB (SCALED)	\$559.87
THOMPSON, WILLIAM L	1107 NORTH 10TH STREET	0772602003014000	HANNON'S ADDITION, BLOCK 4, Lot 3 - 5	\$1,747.80
BROWN, NORMA ANN	1218 OTTAWA STREET	0772603008009000	HERSHFIELD'S,R.N. SUB, BLOCK 1, Lot 37 - 39	\$404.52
CAIRNS, ROBERT A	1410 CENTRAL AVENUE	0773504031021000	INSLEY & SHIRE'S SUB, BLOCK 6, LTS 19 & 20 & S8'LT 21	\$2,108.11
FRESH AIR FOUNDATION	2227 2ND AVENUE	1010103009006000	JOHNSON'S SUBDIVISION, PT BLK 15 JOHNSONS SUB & PT BLK 6 BYINGTONS SUB,BEG SW COR BLK 15 JOHNSONS SUB,N60',E125' S60',W125' TO POB	\$519.92
GENESIS ONE LLC	729 CHESTNUT STREET	0773501030002000	LATTA'S ADDITION, BLOCK 27, Lot 3	\$2,432.75
HEINRICH,CRYSTAL R & MUZA,MARLIN	912 CHEYENNE STREET	0772601304008000	LEA'S & HARSH'S SUB, BLOCK 1, E22'LT 14 & ALL LT 15 & W10'LT 16	\$131.09
GOULD, MARION F	718 MICHIGAN STREET	1010201002005000	LEAS SUBDIVISION, BLOCK 2, Lot 6 - 10	\$513.52
BRUNGARDT, SANDIE	621 KIOWA STREET	0772604103009000	LEAVENWORTH,PLT ORIG , BLOCK 93 , Lot 22.	\$373.22
SWEENEY 2 LLC	520 PAWNEE STREET	0772601406013000	LEAVENWORTH,PLT ORIG, BLOCK 60, Lot 11	\$2,416.34
HUD	631 MIAMI STREET	0772604406005000	LEAVENWORTH,PLT ORIG, BLOCK 77, LT 17 & W12.47'LT 18	\$168.71
BANK OF NEW YORK MELLON	625 KIOWA STREET	0772604103011000	LEAVENWORTH,PLT ORIG, BLOCK 93, Lot 20	\$1,510.20
ALEXANDER, JUSTINE	116 OTTAWA STREET	0772503101005000	LEAVENWORTH,PLT ORIG, S25, T08, R22E, BLOCK 12, Lot 17 - 19	\$2,567.14
PALLESEN, RANDALL D	113 SENECA STREET	0772503405002000	LEAVENWORTH,PLT ORIG, S25, T08, R22E, BLOCK 17, Lot 13	\$2,153.28
PALLESEN, RANDALL D	119 SENECA STREET	0772503405004000	LEAVENWORTH,PLT ORIG, S25, T08, R22E, BLOCK 17, Lot 15 - 16	\$2,479.12
MEDARIS, CATHY ANN	201 OSAGE STREET	0772503107001000	LEAVENWORTH,PLT ORIG, S25, T08, R22E, BLOCK 26, Lot 32	\$2,422.68
SCHWARTZ, NICHOLAS J	219 POTTAWATOMIE STREET	0772503106006000	LEAVENWORTH,PLT ORIG, S25, T08, R22E, BLOCK 27, Lot 23 - 24	\$128.89
BRUMLEY, DAVID	207 OTTAWA STREET	0772503103002000	LEAVENWORTH,PLT ORIG, S25, T08, R22E, BLOCK 28, E1/2 LT 28 & ALL LT 29	\$2,071.96
BOSWELL, RICHANDA Y	301 OTTAWA STREET	0772503207001000	LEAVENWORTH,PLT ORIG, S25, T08, R22E, BLOCK 39, Lot 30 - 32	\$931.96
MULLINS, BRIAN ALAN	317 POTTAWATOMIE STREET	0772503212005000	LEAVENWORTH,PLT ORIG, S25, T08, R22E, BLOCK 40, E1/2 LT 25 & ALL LT 26	\$2,439.88
WESTON, ANGELA D	301 POTTAWATOMIE STREET	0772503212001000	LEAVENWORTH,PLT ORIG, S25, T08, R22E, BLOCK 40, Lot 31 - 32	\$124.19
OLD CANAL FINANCIAL	323 OSAGE STREET	0772503213008000	LEAVENWORTH,PLT ORIG, S25, T08, R22E, BLOCK 41, Lot 21	\$2,602.86
TOUSSEAU, AMY CHEBONNE	806 NEWMAN STREET	0773502040018000	MAPLEWOOD ADD SUB, BLOCK 2, S1/2 LTS 31-34	\$128.98
WELLS, PATRICIA N & STRANGE, E MICHAEL	1504 OSAGE STREET	0782704007031000	MARSHALL'S SUBDIVISION , BLOCK 8 , W100' OF S80' BLK 8.	\$148.00
RICHMOND, LANCE WILLIAM & SULLIVAN, TES	1517 9TH AVENUE	1010201004006000	MARSHALL'S SUBDIVISION, BLOCK 1, N40' OF S180' OF BLK 1	\$453.22
WILMINGTON SAVINGS FUND SOCIETY FSB	776 THORNTON STREET	1010201017021000	MARSHALL'S SUBDIVISION, BLOCK 17, BEG SE COR BLK 17, W100', N TO RW AT&S RR,SELY TO E LI OF BLK 17, S TO POB & ABAN RR ROW ADJ (SCALED)	\$226.30
GALLEGOS, ERNEST E JR	914 OSAGE STREET	0772604303012000	MIX'S SUBDIVISION, BLOCK 2, W8'LT 6 & ALL LT 7	\$113.96
NELSON, GARY A & TONIA L	1306 DAKOTA STREET	0772602016005000	MORRIS METRO SUB BL 1-4, S26, T08, R22E, BLOCK 2, Lot 21 - 22	\$119.00
HASHAGEN, ROBERT H	2311 GIRARD AVENUE	1010204007009000	NEELY'S FOREST ADDITION, BLOCK 6, LT 4 & S14'LT 5& W1/2 VAC ALLEY ADJ	\$549.04
COOPER, JOHN M	3213 GRAND AVENUE	1011102007001180	OAKS, THE , Lot 13.	\$137.00
NANNEN,STEVEN F	617 NORTH 13TH TERRACE	0782704004037000	OTTAWA SUBDIVISION, BLOCK 2, Lot 4, (SCALED)	\$175.00
BURNS, F ROBERT & ELIZABETH C	538 PLEASANT AVENUE	1011203001025000	PLEASANT VIEW SUBDIVISION, Lot 4	\$444.10
LUCAS, LELAND E	1421 SHAWNEE STREET	0783401002004000	R G D REPLAT, Lot 4	\$133.26
FLACK, WYATT	1120 DAKOTA STREET	0772602014013000	RAFTER'S RPLT BL7&8 HANNON'S, BLOCK 7, Lot 6	\$115.00
BROWN, FLOSSIE & KING, DELORES	651 SOUTH STREET	1010102019001000	REES' DONIPHANÞTON'S, BLOCK 14, LT 1 & VAC ALLEY ADJ	\$160.37
BELA VISTA PROPERTIES LLC	1916 2ND AVENUE	1010102022001000	REES' DONIPHANÞTON'S, BLOCK 17, Lot 1 - 3	\$1,200.00

Property Owner	Property Address	CAMA	Legal Description	Billed Amt
SIBOLD, MEGAN & BRADLEY	1611 3RD AVENUE	1010102010004000	REES' DONIPHANÞTON'S, BLOCK 8, Lot 8&9	\$148.51
US BANK TRUST N A	2008 4TH AVENUE	1010102026009000	REES' DONIPHANÞTON'S, S01, T09, R22E, BLOCK 22, Lot 13 - 14	\$316.20
SILVA, MICHAEL	1811 5TH AVENUE	1010102019003010	REES' DONIPHAN&TON'S, BLOCK 14, LTS 8-10 & W1/2 VAC ALLEY ADJ	\$1,615.60
MOHAN, JOSHUA L & JENNIFER	121 SOUTH 20TH STREET	0783402001013000	RUSSELL'S SURVEY, BLOCK 24, S 153' OF W150' OF BLK 24	\$954.00
SOUTH HILLSIDE DEVELOPMENT LLC	2300 WILSON AVENUE	1010104006001130	RUTTER'S REPLAT, S01, T09, R22E, Lot 4	\$1,249.72
BURGESS,KATHY D	1803 DAKOTA STREET	0782703001002000	S27, T08, R22E, PT NE1/4 NE1/4 SW1/4; BEG NW COR LT 1 BLK 1 QUAIL CREEK, S440', W105', N440', E105' TO POB	\$2,922.20
WESLEY PROPERTIES LLC	1531 SPRUCE STREET	0783404003004000	SCHEER'S SUBDIVISION, CORR., BLOCK 3, W30' LT 9 & ALL LTS 10 & 11	\$130.00
VEGA,GEORGE L & ELIZABETH	755 MICHIGAN STREET	1010201010002000	SHOWER'S SUBDIVISION, BLOCK 3, Lot 6	\$123.60
J J & J INCORPORATED	3200 SHRINE PARK ROAD	1011101004040000	SHRINE PARK PUD, S11, T09, R22E, ACRES 41.05, LT 6 EXC TR BEG NW COR LT 3, SW TO NW COR LT 2, SE180', NE636', SE42.4', SW691.5', NW144.5', N193.6', NE755.7', E123.2' TO POB	\$700.00
HERNANDEZ, KETZY	50 LOGAN AVENUE	1010104013009000	SOUTHSIDE PARK SUB, BLOCK 33, Lot 12	\$1,430.47
MATZEDER, ROBERT A	51 LOGAN AVENUE	1010104019001000	SOUTHSIDE PARK SUB, S01, T09, R22E, BLOCK 36, LOT 10-11	\$2,074.16
WILLIAMS, LINDA I	1416 SPRUCE STREET	0783401024017000	STILLINGS 2ND SUB, BLOCK 5, E20' LT 19 & ALL LT 20	\$271.02
TURNER,MICHAEL A & HEATHER	1401 SANDERS STREET	0783401022001000	STILLINGS 2ND SUB, BLOCK 7, LTS 1-9 & E1/2 VAC ALLEY ADJ	\$175.00
GREEN, MICHAEL J	1314 GRAND AVENUE	0773503022010000	STILLING'S BLKS 12-17, BLOCK 13, Lot 38	\$1,559.84
JONES, SCOTT	1226 10TH AVENUE	0773503020014000	STILLING'S BLKS 12-17, BLOCK 15, LT 44 & N1/2 LT 45	\$118.38
LAUN,STEPHAN L & ALICE K	1002 KLEMP STREET	0773503008001000	STILLING'S BLKS 4-8, BLOCK 4, Lot 14 - 15, (SCALED)	\$122.58
H&P DEVELOPMENT LLC	1009 KENTON STREET	0773503010004000	STILLING'S BLKS 4-8, S35, T08, R22E, BLOCK 6, N125.5' LTS 19 & 20	\$1,162.30
BANK OF NEW YORK MELLON	1013 SPRUCE STREET	0773503001006000	STILLING'S, BLKS 1-3, BLOCK 1, Lot 12 - 13	\$279.42
DONALD,PHELPS M & ROSE M	1118 KENTON STREET	0773503002009000	STILLING'S, BLKS 1-3, BLOCK 2, Lot 16 - 18	\$1,082.70
BITTEL PROPERTIES LLC	1123 SPRUCE STREET	0773503002006000	STILLING'S, BLKS 1-3, BLOCK 2, LT 11 & E1/2 LT 12	\$788.13
COLLINS,RALPH & GORDEN,BETTY	1529 10TH AVENUE	1010201006005000	WOLLMAN'S SUB OF W1/2 BLK #4, S02, T09, R22E, Lot 13 - 15	\$541.44
HANSHEW, JAMES E	1513 JACKSON COURT	1010202004044000	WOODLAWN SUBDIVISION, BLOCK 1, Lot 14	\$125.00
WOODS ON MUNCIE ASSOC	1150 MUNCIE ROAD	1011103004026000	WOODS ON MUNCIE, S11, T09, R22E, BLOCK 1, Lot TRACT A, ACRES 3.58 I	\$175.00
			Grand Total	\$101,112.82

Policy Report
Mosquito Program Discussion
Aug. 14, 2018

Prepared by:

A handwritten signature in black ink, appearing to read 'Paul Kramer', written over a horizontal line.

Paul Kramer
City Manager

Issue:

Kansas State University Entomologists Jeff Whitworth (PhD) and Holly Davis (PhD) will speak to the Commission about the City's mosquito program and mosquito control in general.

Drs. Whitworth and Davis will also be available to answer Commissions questions related to this topic.

**Policy Report No. FIN-18-03
Public Hearing on the Proposed 2019 Budget**

August 14, 2018

Prepared By:



Ruby Maline
Finance Director

Approved By:



Paul Kramer
City Manager

Issue:

According to State statute, the City Commission must hold a Public Hearing prior to adopting the 2019 City Budget in order to receive citizen comment. Attached please find a copy of the notice of public hearing that was published in *The Leavenworth Times*.

By resolution the Commission must also adopt the 2019 Housing Budget.

Recommendation:

Staff recommends that the City Commission:

- Hold the required public hearing and then consider the adoption of the proposed 2019 budget with or without amendment, and
- Adopt the 2019 Housing budget.

Background:

Last month, staff presented to the City Commission the proposed 2019 budget. Attached is the budget transmittal letter that provides an overview of 2019 budget issues, budget summary, and a resolution adopting the 2019 Housing budget.



July 11, 2018

Mayor and City Commission

City of Leavenworth

Leavenworth, Kansas

Dear Mayor and Commissioners:

The City of Leavenworth Management Team is pleased to present the 2019 Operating Budget. It is a balanced budget, as required by law, and builds on the City's goal to provide high-quality services while maintaining sound financial standing. The budget contains revenue and expenses for all City funds and includes a "pass-through" levy as mandated by the Library Ordinance. The proposed mill levy that supports City of Leavenworth operations remains unchanged from 2018. However, the library has requested a 0.385 mill increase for their Library Employee Benefits Fund.

The Management Team has evaluated economic trends, City Commission priorities and adopted goals, public discourse and feedback, staff recommendations and many other factors while drafting the 2019 budget. The following issues, in context of their relation to available resources, were discussed at length in development of the 2019 budget:

- Budgeting for the mid-year addition of a Community Development Director to reassume housing authority duties and work on directed community improvement projects/programs.
- Funding of court-ordered nuisance abatement in a way that brings more expedient relief to neighborhoods.
- Implementing a portion of the commissioned employee classification and compensation study.
- A new budget line item for aesthetic improvements in City parks and budging for tree removal of infected ash trees.
- Employee health/welfare and retirement expenses.

General Fund

The City's General Fund accounts for core municipal functions and services such as Police, Fire, Parks and Recreation, Public Works, Planning and Administration. This is an operating budget focused primarily on revenues coming and going in a particular fiscal year. The primary revenue streams that support the General Fund budget are: 1) Sales and Use Taxes; 2) Property Taxes; 3) Charges for Services; 4) Fines and Forfeitures; and 5) Franchise Fees. Fluctuations in these revenue streams impact how the City is able to pay for and maintain core services.

Revenue Highlights

- The City experienced an increase in initial assessed valuation from \$207,179,358 in 2018 to \$212,395,600 in 2019 – an increase of 2.5%.
- Total sales tax revenues in the Tax Funds are budgeted to increase \$888,019, or 3.5%, over 2018. Several other revenue sources increased, including property tax (\$172,000), franchise fees (\$43,091) and motor vehicle tax (\$78,924). The most substantial decline is in court fines/fees (- \$175,000).
- There is a small increase in other revenue sources, including Motor Vehicle Tax and licenses and permits.

Additionally, the General Fund includes a budgeted reserve of \$2,540,165, which is available to support unanticipated expenses or underperforming revenues.

Expense Highlights

- The Riverfront Community Center requires an operating subsidy of \$400,000 in the 2019 Operating Budget. Everything from insurance to supplies and maintenance increase year-to-year, without corresponding changes in revenue. Future changes in either revenue or expenses will need to occur to freeze or reduce the trend in escalating operating subsidies.
- The inclusion of \$60,000 to hire a Community Development Director mid-year.
- City contributions to the Police and Fire KP&F State Pension system and in the KPERS State Pension system contribution rate for all other City employees saw an increase for 2019 of \$59,695.
- Health insurance costs are budgeted to increase 8% (which would equate to \$241,919), although the exact amount is unknown at this time. There are also slight increases to dental and vision costs.
- The introduction of Fire Department specialty assignment pay (similar to what was implemented for the Police Department in 2018) is included for HazMat and Investigation functions at a cost of \$13,200.
- Increasing the legal budget by \$50,000 to reflect staffing changes.

It is recommended that the 2019 employee compensation plan include a 2.75% across the board increase for employees, implemented mid-year. The compensation plan is in-line with those being provided by most municipalities in the region. Along with the increase, the budget includes a \$100,000 set-aside for implementation of the yet-to-be-completed classification and compensation study. It is unclear at this time what the phasing plan will be for implementation of the study.

Other budgets included

It is again useful to consider the 2019 budget document as consisting of four separate budgets: Library Funds, Federal Grant Funds, Non-Tax Funds and Tax Funds. The recommended budget is for the mill rate to remain the same for City activities 26.768 and 4.979 for the library for a total mill levy of 31.747

Library

The Library Ordinance is set at 3.75 mills, which generates \$796,403 for operations. Additionally, there is a second levy for the Library Employee Benefits Fund (EBF). That levy fluctuates based on cost and is currently requested to increase from 0.844 to 1.229, which will generate \$261,126. The library also receives other (motor vehicle and delinquent taxes) funding.

Federal Grant Funds

The City receives grants each year for Planters II, Section 8, Community Development, and Comprehensive Improvements Assistance Program (CIAP) activities. The 2019 Planters II expense budget increased \$246,41 over 2018 - in most part as budgeted reserves - \$61,801 over the 2018 budget, and \$64,065 over 2017 actuals. Increases in expenditures are due to increased health insurance, electric and gas utilities, and increased buildings and grounds maintenance. The financial condition of the Fund is stable. The 2019 Section 8 Fund expense budget increases by \$157,282 to \$1,768,385, mostly because of increases in anticipated housing payments.

The 2018 Community Development Block Grant funds are estimated to increase to \$334,736. \$66,947 may be used for administrative purposes; the balance, or \$267,789, is used for a variety of community projects in accordance with CDBG guidelines.

The CIAP Fund (Planters II Capital Fund) was established to account for federal grants received each year for repairs and renovations to the Planters II facility. The Fund will begin 2019 with a balance of \$237,274 while federal grant revenue of \$139,790 is budgeted for the year. Thus, total resources in 2019 are \$377,064 and are budgeted for building improvements.

The Blight Elimination Trust Fund is budgeted at \$13,572 for 2019. The Fund accounts for housing-related blight elimination and rehabilitation activities. The ESG Fund is a state funded emergency shelter grant. The 2019 amount for the ESG grant is anticipated to be \$37,486.

Non-Tax Funds

These Funds derive their financial support from sources other than ad valorem taxes. Expense budget levels for these Funds are generally dependent upon the availability of revenue generated through the pursuit of the Fund's activity. For example, the Sewer Fund expense budget is dependent upon funds generated from the sale of sewer services.

The 2019 expense base budget for this group of Funds increases \$6,311,252 or 47%, to \$19,816,545. These increases are due to FFE funds of \$1,000,000 carried over from 2017 that are restricted for capital outlay for streets; increased TIF payouts; increased activity in the Economic Development and CVB funds; and increased activity in the sewer and refuse funds.

Fund	2018 Budget	2019 Budget
Countywide Sales Tax	2,534,892	3,728,062
Streets	2,298,974	2,149,944
CIP Sales Tax Fund	3,261,963	2,607,792
Zeck TIF Fund	866,871	804,711
Econ Develop Fund	956,423	950,265
Probation Fund	185,505	255,522
Sewer	5,944,671	5,811,099
Refuse	2,195,269	2,295,911
Refuse Restricted	17,049	35,760
Police Seizure	157,592	157,592
CVB Fund	681,081	872,311
Hotel TIF Fund	430,801	529,174
Home Depot Tax Increment	255,454	359,838
Special Park Gift	30,000	30,000
Total	\$19,816,545	\$20,587,981

The 2019 Streets Fund operating budget increases \$149,030, or 6.5%, from the 2018 budget due to decreases in budgeted capital outlay. The anticipated subsidy transfer from the General Fund remains at \$80,000.

The Convention and Visitor's Bureau Fund was established in 2014 to account for the receipt of transient guest tax revenue that had previously been accounted for in the General Fund. The Fund began 2018 with \$384,172 and an additional \$350,000 in revenue was budgeted during 2018. The 2019 budget will begin with \$387,788. The operating budget revenue increases to \$440,000 due to anticipated revenue increases from new hotels. Budgeted expenses are \$301,824. Operating Reserves are budgeted at \$525,964 to be available should other projects become identified.

The 2019 Sewer Fund budget remains stable; Long-term financing analysis of the Fund indicates that a utility rate increase of 3% will be required for expenditures at the sewer plant and will generate an additional \$67,907 in utility revenue this year. Gross revenue is budgeted rather than the net amount. The gross revenue includes the water department billing fees. Budgeted expenditures include those fees as an expenses and therefore, the two offset each other.

The 2019 Refuse Restricted Fund beginning balance is expected to be \$25,760 and a \$10,000 transfer from the Refuse Fund will result in total 2019 resources of \$35,760. Budgeted 2019 expenditures include \$6,500 for mowing fees and \$29,260 for erosion control activities.

The 2019 Refuse Fund expense budget long-term financing analysis of the Fund indicates that a utility rate increase of 5% will be required for future capital expenditures for a refuse truck and will generate an additional \$100,792 in utility revenue.

The Home Depot Tax Increment Fund was established to account for the receipt and distribution of funds received from Home Depot as required by the tax increment financing agreement initiated in 2003. It is estimated that approximately \$359,838 will be paid to Home Depot in accordance with the agreement.

Two additional TIF funds were added to account for the collection and distribution of funds as required by tax increment financing agreements with Zeck Ford, First City Hotels, and Home 2 Suites Hotel. Zeck Ford TIF fund is anticipated to have \$804,711 paid out and the Hotel TIF funds are anticipated to have \$529,174 paid out.

No Supplemental Requests are recommended for this group of Funds.

Bond and Interest Fund

The 2019 Bond & Interest Fund expense budget increases \$110,448 due to increased debt service payments. Budgeted 2019 payments consisted of principal of \$3,015,000 and interest of \$530,687, and capital lease payment of \$164,840 for a total of \$3,710,227. New debt payment for 2019 includes principal of \$115,000 and interest of \$49,938 for the 2017 general improvements bonds.

Assessed Valuation

Based upon information recently received from the County Clerk, the City of Leavenworth experienced an increase in assessed valuation from \$207,227,412 to \$212,395,600. This is about a 2.5% increase; however, tax abatement property values increased to \$2,687,061.

	2018	2019	
	Budget	Budget	Variance
Real Property	\$191,282,464	\$196,347,637	\$5,065,173
Personal Property	4,105,653	4,009,374	-\$ 96,279

State Assessed Utilities	11,839,295	12,038,589	\$ 199,294
Total	\$207,227,412	\$212,395,600	\$5,168,188

Ad Valorem Taxes

The following table illustrates the 2019 ad valorem tax levy (prior to the delinquency rate calculation) required by each City Fund.

Fund	2018 Budget	2019 Budget	Variance
General Fund	\$3,437,745	\$3,430,109	-.23%
Recreation	377,498	483,670	21.95%
Bond & Interest	1,581,891	1,621,569	2.44%
Fire Pension	133,401	136,257	2.1%
Police Pension	12,477	13,605	.00%
Subtotal - City	5,543,012	5,685,210	2.5%
Library Fund	777,113	796,403	2.5%
Library Employee Benefits	174,894	261,126	35.52%
Subtotal - Library	952,007	1,057,529	9.98%
Total	\$6,495,019	\$6,742,739	3.68%

Mill Levies

The table below illustrates the 2019 mill levy rate for each City Fund requiring ad valorem tax support given the assessed valuation data provided by the County Clerk.

Fund	2018 Budget	2019 Budget	Variance
General Fund	16.589	16.150	-.439
Recreation	1.822	2.277	.455
Bond & Interest	7.634	7.635	0.001
Fire Pension	0.644	0.642	-0.002
Police Pension	0.060	0.064	0.004
Subtotal - City	26.749	26.768	0.019
Library Fund	3.750	3.750	0.000
Library Employee Benefits	0.844	1.229	0.385
Subtotal - Library	4.594	4.979	0.385
Total	31.343	31.747	0.404

Conclusion

The 2019 recommended operating budget reflects the continuation of modest, yet positive growth in revenue and service delivery. The recommended budget proposes to invest further in employee development and workforce stabilization while making small enhancements in public works, blight removal and parks and recreation with a completely flat City funded mill rate. Additionally, revenue trends and careful consideration of expenses in previous few years has allowed the City to sustain pre-recession reserve levels.

As with any budget process, certain areas were selected for enhancements, while others that were equally affected by cuts in previous years remained unchanged. We hope the proposed budget matches the goals and expectations of the residents of Leavenworth and the City Commission.

We appreciate the support of the staff in the preparation and presentation of the 2019 City recommended budget and we look forward to reviewing its contents with the City Commission.

Sincerely,



Paul Kramer
City Manager



Ruby Maline
Finance Director

CERTIFICATE

To the Clerk of Leavenworth County, State of Kansas

We, the undersigned, officers of

City of Leavenworth, Kansas

certify that: (1) the hearing mentioned in the attached publication was held;
(2) after the Budget Hearing this budget was duly approved and adopted as the
maximum expenditures for the various funds for the year 2019; and
(3) the Amount(s) of 2018 Ad Valorem Tax are within **statutory** limitations.

			2019 Adopted Budget		
			Budget Authority	Amount of 2018	County
			for Expenditures	Ad Valorem	Clerk's
				Tax	Use Only
Table of Contents:			Page		
			No.		
Computation to Determine Limit for 2019			2		
Allocation of MVT, RVT, 16/20M Veh Tax			3		
Schedule of Transfers			4		
Statement of Indebtedness			5		
Statement of Lease-Purchases			6		
Computation to Determine State Library Grant			7		
Fund K.S.A.					
General	12-101a	8	22,751,464	3,478,645	
Debt Service	10-113	9	3,821,027	1,621,608	
Library	12-1220	9	900,600	796,403	
Library Employee Benefit	12-16,102	10	284,000	261,126	
Recreation	12-1927	10	1,677,861	483,670	
Police Pension	13-14a01	11	166,800	13,605	
Fire Pension	13-14a02	11	630,000	87,871	
Special Highway		12	2,152,244		
Economic Development		12	968,336		
CIP Sales Tax		13	2,650,062		
County Wide Sales Tax		13	3,830,459		
CVB		14	872,311		
Probation		14	255,522		
TIF-Zeck		15	804,711		
TIF-Hotels		15	404,174		
TIF-Home Depot		16	391,759		
Sewer		16	5,843,546		
Refuse		17	2,368,352		
Refuse Restricted		17	35,760		
Non-Budgeted Funds-A		18			
Totals		xxxxxx	50,808,988	6,742,928	
Budget Summary		18			County Clerk's Use Only
Neighborhood Revitalization Rebate					Nov 1, 2018 Total Assessed Valuation

Tax Lid Limit (from Computation Tab) 7,411,599
Does the City need to hold an election? NO

Assisted by: _____

Address: _____

Email: _____

Attest: _____, 2018

County Clerk

Governing Body

CPA Summary

NOTICE OF BUDGET HEARING

2019

The governing body of
City of Leavenworth, Kansas
will meet on August 14, 2018 at 7:00 PM at City Hall for the purpose of hearing and
answering objections of taxpayers relating to the proposed use of all funds and the amount of ad valorem tax.
Detailed budget information is available at City Hall and will be available at this hearing.

BUDGET SUMMARY

Proposed Budget 2019 Expenditures and Amount of 2018 Ad Valorem Tax establish the maximum limits of the 2019 budget.
Estimated Tax Rate is subject to change depending on the final assessed valuation.

FUND	Prior Year Actual for 2017		Current Year Estimate for 2018		Proposed Budget Year for 2019		
	Expenditures	Actual Tax Rate *	Expenditures	Actual Tax Rate *	Budget Authority for Expenditures	Amount of 2018 Ad Valorem Tax	Estimate Tax Rate *
General	17,209,531	15.356	19,080,212	16.593	22,751,464	3,478,645	16.378
Debt Service	2,978,102	8.129	3,710,511	7.635	3,821,027	1,621,608	7.635
Library	842,000	3.706	885,271	3.750	900,600	796,403	3.750
Library Employee Benefit	191,000	0.845	199,571	0.844	284,000	261,126	1.229
Recreation	1,568,903	2.600	1,596,904	1.822	1,677,861	483,670	2.277
Police Pension	14,738	0.060	15,819	0.060	166,800	13,605	0.064
Fire Pension	122,183	0.647	124,213	0.644	630,000	87,871	0.414
Special Highway	1,177,106		1,158,465		2,152,244		
Economic Development	230,998		407,102		968,336		
CIP Sales Tax	2,112,144		2,942,924		2,650,062		
County Wide Sales Tax	1,890,907		2,207,651		3,830,459		
CVB	245,936		295,728		872,311		
Probation	155,800		177,505		255,522		
TIF-Zeck	617,399		817,439		804,711		
TIF-Hotels	500,392		354,390		404,174		
TIF-Home Depot	265,495		254,000		391,759		
Sewer	4,632,589		4,811,313		5,843,546		
Refuse	2,030,786		2,045,112		2,368,352		
Refuse Restricted	10,740		17,049		35,760		
Non-Budgeted Funds-A	2,668,406						
Totals	39,465,155	31.343	41,101,179	31.348	50,808,988	6,742,928	31.747
Less: Transfers	4,095,826		4,295,838		4,318,975		
Net Expenditure	35,369,329		36,805,341		46,490,013		
Total Tax Levied	6,383,650		6,495,016		XXXXXXXXXXXXXXXXXX		
Assessed Valuation	203,654,933		207,179,358		212,395,600		
Outstanding Indebtedness, January 1,							
G.O. Bonds	25,485,000		25,840,000		20,765,000		
Revenue Bonds	0		0		0		
Other	2,410,000		1,660,000		2,070,000		
Lease Purchase Principal	39,348		0		329,680		
Total	27,934,348		27,500,000		23,164,680		

*Tax rates are expressed in mills

Carla Williamson
City Official Title: City Clerk

Leavenworth Times

Publication

NOTICE OF BUDGET HEARING

State of Kansas
City

The governing body of
City of Leavenworth, Kansas

will meet on August 14, 2018 at 7:00 PM at City Hall for the purpose of hearing and answering objections of taxpayers relating to the proposed use of all funds and the amount of ad valorem tax. Detailed budget information is available at City Hall and will be available at this hearing.

2019

BUDGET SUMMARY

Proposed Budget 2019 Expenditures and Amount of 2018 Ad Valorem Tax establish the maximum limits of the 2019 budget. Estimated Tax Rate is subject to change depending on the final assessed valuation.

FUND	Prior Year Actual for 2017		Current Year Estimate for 2018		Proposed Budget Year for 2019		
	Expenditures	Actual Tax Rate *	Expenditures	Actual Tax Rate *	Budget Authority for Expenditures	Amount of 2018 Ad Valorem Tax	Estimate Tax Rate *
General	17,209,531	15.356	19,080,212	16.593	22,751,464	3,478,645	16.378
Debt Service	2,978,102	8.129	3,710,511	7.635	3,821,027	1,621,608	7.635
Library	842,000	3.706	885,271	3.750	900,600	796,403	3.750
Library Employee Benefit	191,000	0.845	199,571	0.844	284,000	261,126	1.229
Recreation	1,568,903	2.600	1,596,904	1.822	1,677,861	483,670	2.277
Police Pension	14,738	0.060	15,819	0.060	166,800	13,605	0.064
Fire Pension	122,183	0.647	124,213	0.644	630,000	87,871	0.414
Special Highway	1,177,106		1,158,465		2,152,244		
Economic Development	230,898		407,102		968,136		
CIP Sales Tax	2,112,144		2,942,924		2,650,062		
County Wide Sales Tax	1,890,907		2,207,651		3,930,459		
CVB	245,936		295,728		872,311		
Probation	155,800		177,505		255,522		
TIF-Truck	617,399		817,439		804,711		
TIF-Retail	500,392		354,190		404,174		
TIF-Home Depot	265,495		254,000		391,759		
Sewer	4,632,589		4,811,313		5,843,546		
Refuse	2,030,786		2,045,112		2,368,352		
Refuse Restricted	10,740		17,049		35,760		
Non-Budgeted Funds-A	2,608,406						
Totals	39,465,155	31.343	41,101,179	31.348	50,808,988	6,742,928	31.747
Less Transfers	4,095,820		4,295,838		4,318,075		
Net Expenditure	35,369,329		36,805,341		46,490,913		
Total Tax Levied	6,383,650		6,495,016				
Assessed Valuation	203,654,933		207,179,358		212,395,000		
Outstanding Indebtedness, January 1,	2016	2017	2018				
O.O. Bonds	23,485,000	25,840,000	20,765,000				
Revenue Bonds	0	0	0				
Other	2,410,000	1,660,000	2,070,000				
Lease Purchase Principal	39,348	0	329,680				
Total	27,934,348	27,500,000	23,164,680				

*Tax rates are expressed in mills

Carla Williamson

Carla Williamson

City Official Title - City Clerk



Published in the Leavenworth Times July 31, 2018

lawful age, being first duly sworn Representative of the Times a daily Leavenworth, Leavenworth County, published for a least Fifty (50) years prior to the date of publication for at least five (5) years prior to the date of publication on a yearly basis in Leavenworth County, Kansas and has a religious or fraternal publication and Leavenworth County, Kansas and has a . The attached Notice was a regular issue of said newspaper.

Publication was made on the 31 day of July, 2018.

Publication was made on the _____ day of _____, 20____.

Publication was made on the _____ day of _____, 20____.

Publication was made on the _____ day of _____, 20____.

Publication was made on the _____ day of _____, 20____.

Publication was made on the _____ day of _____, 20____.

Seventh Publication was made on the _____ day of _____, 20____.

WITNESS my hand this 31 day of July, 2018.

Sammy Lawson

Legal Representative

Subscribe and sworn before me, this the 31 day of July, 2018.

Rebecca A. Broom

Notary Public

My Commission Expires: 6/7/19



RESOLUTION B-2204
2019 HOUSING BUDGET

**A RESOLUTION ESTABLISHING THE 2019 HOUSING BUDGET
AND SPECIFICALLY THE OPERATING BUDGET FOR
PLANTER'S II, LEAVENWORTH, KANSAS**

BE IT RESOLVED by the Mayor and City Commission, acting as the Public Housing Authority (PHA) for Leavenworth, Kansas, as follows:

Section 1. The 2019 Operating Budget for Planter's II is hereby adopted.

Section 2. The Proposed expenditures are necessary in the efficient and economical operation of the Housing agency for the purpose of serving low-income families.

Section 3. The financial plan is reasonable in that: it indicates a source of funding to cover all proposed expenditures and it does not provide for use of federal funds in excess of that payable under the provisions of 24 CFR 890, Subpart A.

Section 4. All proposed rental charges and expenditures will be consistent with the provisions of law and the annual contributions contract.

Section 5. Pursuant to Section 960.209 of the final rule effective May 21, 1984, the PHA is re-examining the incomes of all families living in the project at least once a year.

Section 6. No PHA employee reflected in the proposed operating budget is serving in a variety of positions which will exceed a 100% allocation of his/her time.

Section 7. This resolution also adopts the budget of expenditures and revenue earnings from administrative fees associated with Section 8 - existing housing assistance payments made on behalf of participant - tenants in the certificate, voucher and HOME tenant based assistance programs.

Section 8. This resolution shall be effective January 1, 2019.

Passed and Approved this 14th day of August, 2018.

Mark Preisinger, Mayor

{SEAL}

ATTEST:

Carla K. Williamson, City Clerk, CMC

Policy Report No. 10-2018
2018 Edward Byrne Memorial Justice Assistance Grant Application
August 14, 2018

Prepared by:

Patrick R. Kitchens, Police Chief

Approved by:

Paul Kramer, City Manager

for

ISSUE:

The Police Department is requesting authority to apply for the 2018 Edward Byrne Memorial Justice Assistance Grant in the amount of \$25,170.00.

STAFF RECOMMENDATION:

Staff recommends approval.

BACKGROUND:

On July 23, 2018 the U.S. Department of Justice released the annual Edward Byrne Memorial Justice Assistance Grant local solicitation and identified the City of Leavenworth, Kansas as eligible for \$25,170.00. This is an annual grant made available to law enforcement agencies in the United States and we have experienced great success with these funds. Typically, we have used these funds to purchase police equipment.

This grant application requires the City of Leavenworth to share this allocation with Leavenworth County as they are categorized in the disparate grouping. The allocation is based upon a formula which provides the City of Leavenworth will receive \$15,170.00 and Leavenworth County will receive \$10,000.00. The City of Leavenworth must apply for this grant on behalf of both entities.

The Leavenworth County Sheriff's Office intends to use the funds to purchase law enforcement equipment.

BUDGET IMPACT:

No City of Leavenworth funds are necessary for this grant application.

COMMISSION ACTION:

Authorize the Police Department to apply for the 2018 Edward Byrne Memorial Justice Assistance Grant in the amount \$25,170.00 of which \$10,000.00 will be given to Leavenworth County Sheriff's Office. This action requires the City Manager and City Attorney to sign an Interlocal agreement with Leavenworth County.

Further, it requires the Mayor to sign an additional document entitled "Certifications and Assurances by the Chief Executive of the Applicant Government."

Listed below are all jurisdictions in the state that are eligible for FY 2018 JAG funding, as determined by the JAG formula. For additional details regarding the JAG formula and award calculation process, with examples, please refer to the updated JAG Technical report here: <https://www.bja.gov/Jag/pdfs/JAG-Technical-Report.pdf> and current JAG Frequently Asked Questions here: <https://www.bja.gov/Funding/JAGFAQ.pdf>.

Finding your jurisdiction:

- (1) Disparate jurisdictions are listed in shaded groups below, in alphabetic order by county.
- (2) Eligible individual allocations are listed alphabetically below the shaded, disparate groupings.
- (3) Counties that have an asterisk (*) under the "Eligible Individual Allocation" column did not submit the level of violent crime data to qualify for a direct award from BJA, but are in the disparate grouping indicated by the shaded area. The JAG legislation requires these counties to remain a partner with the local jurisdictions receiving funds and must be a signatory on the required Memorandum of Understanding (MOU). A sample MOU is provided online at: <https://www.bja.gov/Funding/JAGMOU.pdf>. Disparate jurisdictions do not need to abide by the listed individual allocations, which are provided for information only. Jurisdictions in a funding disparity are responsible for determining individual amounts within the Eligible Joint Allocation and for documenting individual allocations in the MOU.

State	Jurisdiction Name	Government Type	Direct Allocation	Joint Allocation
KS	DOUGLAS COUNTY	County	*	
KS	LAWRENCE CITY	Municipal	\$32,062	\$32,062
KS	FINNEY COUNTY	County	*	
KS	GARDEN CITY	Municipal	\$14,951	\$14,951
KS	FORD COUNTY	County	*	
KS	DODGE CITY	Municipal	\$10,699	\$10,699
KS	GEARY COUNTY	County	*	
KS	JUNCTION CITY CITY	Municipal	\$16,666	\$16,666
KS	HARVEY COUNTY	County	*	
KS	NEWTON CITY	Municipal	\$10,665	\$10,665
KS	JOHNSON COUNTY	County	*	
KS	OLATHE CITY	Municipal	\$17,146	
KS	OVERLAND PARK CITY	Municipal	\$37,789	
KS	SHAWNEE CITY	Municipal	\$12,516	\$67,451
KS	LEAVENWORTH COUNTY	County	*	
KS	LEAVENWORTH CITY	Municipal	\$25,170	\$25,170
KS	RENO COUNTY	County	*	
KS	HUTCHINSON CITY	Municipal	\$22,221	\$22,221

City of Leavenworth, Kansas
Parks & Recreation Department
Cody Park Playground
POLICY REPORT NO. P&R 08-18

August 14, 2018

PREPARED BY:

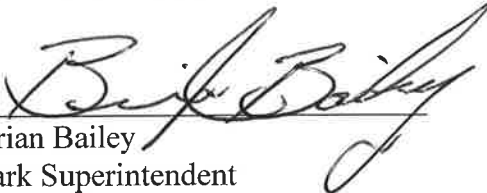
Brian Bailey
Park Superintendent

REVIEWED BY:

Steve Grant
Parks and Recreation Director

Paul Kramer
City Manager

ISSUE:

To review proposals submitted for replacement of playground unit/equipment for Cody Park.

BACKGROUND:

The playground composite structure at Cody Park was installed in 1999. In the most recent years the manufacturer quit making or are limited on what replacement parts are available for the existing unit. As a result, staff has had to remove sections and repair the unit with limited parts from the manufacturer. The playground unit has reached the point that its playability and overall condition of the structure has deteriorated and is in need of replacement or removal.

As a result, staff formulated a set of guidelines from which to receive proposals for design and replacement of the unit. Proposals were to take into account on appearance, play value, vandal resistance, sturdiness, and time constraints. Interested firms were given the guideline of a \$125,400 budgeted amount to not exceed. From there it would be a qualifications based selection.

On August 1, 2018 the submitted proposals were opened. Four firms submitted proposals, and one with more than one option. One of the options from that firm was disqualified because it did not meet the recommended requirements. The results are as follows:

BIDDER	Playground Equipment Brand
Cunningham Assoc. Inc.	GameTime
AB Creative	Burke
Fry & Associates	PlayWorld
J. Oliver Construction, LLC	Henderson

RECOMMENDATION:

The Parks and Community Activities Advisory Board reviewed and discussed the proposals at their August 6th meeting. Based on playability, sturdiness, design, and appearance, the Board recommends the proposal from J. Oliver Construction, LLC, for the purchase and installation of Henderson playground equipment for Cody Park for the amount of \$124,500.

BUDGET IMPACT:

There is \$125,400 allocated in the 2018 Capital Improvement Program for this project.

ATTACHMENTS:

- J. Oliver Construction, LLC Proposal
- J. Oliver Construction, LLC, Renderings

Request for Proposal No: RFP-2018-14
PROPOSAL FOR CODY PARK
PLAYGROUND EQUIPMENT

Price for Proposed Playground and Installation \$ 124,500.00

Warranty: See attached documents

Unit Conforms with Guidelines Yes No

Delivery Time: Equipment Delivery 5 weeks - completion within 60 days

Company Name: J. Oliver Construction LLC

Address: 3408 Pomeroy Dr.

City: Kansas City State: KS Zip: 66109

Phone Number: 913-961-0330 Fax Number: _____

Authorized Individual's Name and Title (Please print or type):

Lyndsay Moore - Sales Rep

Authorized Signature: *L Moore*

Date: 07/31/2018

CODY PARK



JOLIVER
CONSTRUCTION LLC

Model No. B502673R1

Color: Blue
 Accent: Green
 Back Material: Plastic
 Main Material: Extruded Vinyl Plastic
 Safety: Soft Fall - 15mm (0.59")

Components

Item	Qty	Part No.	Description
1	1	1000000000	Slide
2	1	1000000000	Slide
3	1	1000000000	Slide
4	1	1000000000	Slide
5	1	1000000000	Slide
6	1	1000000000	Slide
7	1	1000000000	Slide
8	1	1000000000	Slide
9	1	1000000000	Slide
10	1	1000000000	Slide
11	1	1000000000	Slide
12	1	1000000000	Slide
13	1	1000000000	Slide
14	1	1000000000	Slide
15	1	1000000000	Slide
16	1	1000000000	Slide
17	1	1000000000	Slide
18	1	1000000000	Slide
19	1	1000000000	Slide
20	1	1000000000	Slide
21	1	1000000000	Slide
22	1	1000000000	Slide
23	1	1000000000	Slide
24	1	1000000000	Slide
25	1	1000000000	Slide
26	1	1000000000	Slide
27	1	1000000000	Slide
28	1	1000000000	Slide
29	1	1000000000	Slide
30	1	1000000000	Slide
31	1	1000000000	Slide
32	1	1000000000	Slide
33	1	1000000000	Slide
34	1	1000000000	Slide
35	1	1000000000	Slide
36	1	1000000000	Slide
37	1	1000000000	Slide
38	1	1000000000	Slide
39	1	1000000000	Slide
40	1	1000000000	Slide
41	1	1000000000	Slide
42	1	1000000000	Slide
43	1	1000000000	Slide
44	1	1000000000	Slide
45	1	1000000000	Slide
46	1	1000000000	Slide
47	1	1000000000	Slide
48	1	1000000000	Slide
49	1	1000000000	Slide
50	1	1000000000	Slide
51	1	1000000000	Slide
52	1	1000000000	Slide
53	1	1000000000	Slide
54	1	1000000000	Slide
55	1	1000000000	Slide
56	1	1000000000	Slide
57	1	1000000000	Slide
58	1	1000000000	Slide
59	1	1000000000	Slide
60	1	1000000000	Slide
61	1	1000000000	Slide
62	1	1000000000	Slide
63	1	1000000000	Slide
64	1	1000000000	Slide
65	1	1000000000	Slide
66	1	1000000000	Slide
67	1	1000000000	Slide
68	1	1000000000	Slide
69	1	1000000000	Slide
70	1	1000000000	Slide
71	1	1000000000	Slide
72	1	1000000000	Slide
73	1	1000000000	Slide
74	1	1000000000	Slide
75	1	1000000000	Slide
76	1	1000000000	Slide
77	1	1000000000	Slide
78	1	1000000000	Slide
79	1	1000000000	Slide
80	1	1000000000	Slide
81	1	1000000000	Slide
82	1	1000000000	Slide
83	1	1000000000	Slide
84	1	1000000000	Slide
85	1	1000000000	Slide
86	1	1000000000	Slide
87	1	1000000000	Slide
88	1	1000000000	Slide
89	1	1000000000	Slide
90	1	1000000000	Slide
91	1	1000000000	Slide
92	1	1000000000	Slide
93	1	1000000000	Slide
94	1	1000000000	Slide
95	1	1000000000	Slide
96	1	1000000000	Slide
97	1	1000000000	Slide
98	1	1000000000	Slide
99	1	1000000000	Slide
100	1	1000000000	Slide

Henderson
Providing Playground Fun



CODY PARK



J. OLIVER
CONSTRUCTION LLC

Model No. B502673R1

Model No. B502673R1
 15' x 15' x 15' (H x W x D)
 15' x 15' x 15' (H x W x D)
 15' x 15' x 15' (H x W x D)
 15' x 15' x 15' (H x W x D)

Components

1. 15' x 15' x 15' (H x W x D)
 2. 15' x 15' x 15' (H x W x D)
 3. 15' x 15' x 15' (H x W x D)
 4. 15' x 15' x 15' (H x W x D)
 5. 15' x 15' x 15' (H x W x D)
 6. 15' x 15' x 15' (H x W x D)
 7. 15' x 15' x 15' (H x W x D)
 8. 15' x 15' x 15' (H x W x D)
 9. 15' x 15' x 15' (H x W x D)
 10. 15' x 15' x 15' (H x W x D)

Henderson
Providing Playground Fun



CODY PARK



JOLIVER
CONSTRUCTION LLC

Model No. B502673R1

Capacity: 1000
 Weight: 15000 lbs
 Height: 12 ft
 Depth: 20 ft
 Width: 15 ft
 Material: Steel
 Color: Blue, Green

Components

<ul style="list-style-type: none"> 1. Playhouse 2. Slide 3. Tunnel 4. Climbing Wall 5. Monkey Bars 6. Swing Set 	<ul style="list-style-type: none"> 7. Platform 8. Railing 9. Stairs 10. Support Posts 11. Connectors 12. Handrails 13. Safety Mats 	<ul style="list-style-type: none"> 14. Swing Seats 15. Swing Chains 16. Swing Hangers 17. Swing Posts 18. Swing Bases 19. Swing Seats 	<ul style="list-style-type: none"> 20. Swing Seats 21. Swing Chains 22. Swing Hangers 23. Swing Posts 24. Swing Bases 25. Swing Seats
---	---	---	---

Henderson
Providing Playground Fun



CODY PARK



JOLIVER
CONSTRUCTION LLC

Model No. B502673R1

100' x 100'
 40' x 20' x 10' x 10' x 10' x 10'
 100' x 100' x 10' x 10' x 10' x 10'
 100' x 100' x 10' x 10' x 10' x 10'

Components

100' x 100' x 10' x 10' x 10' x 10'
 100' x 100' x 10' x 10' x 10' x 10'
 100' x 100' x 10' x 10' x 10' x 10'
 100' x 100' x 10' x 10' x 10' x 10'
 100' x 100' x 10' x 10' x 10' x 10'
 100' x 100' x 10' x 10' x 10' x 10'

Henderson®
Providing Playground Fun



ADA Accessibility Guideline

ELEVATED	ACCESSIBLE	RAMP ACCESSIBLE	GROUND TYPES
23	18/12	11	8/8 5/4

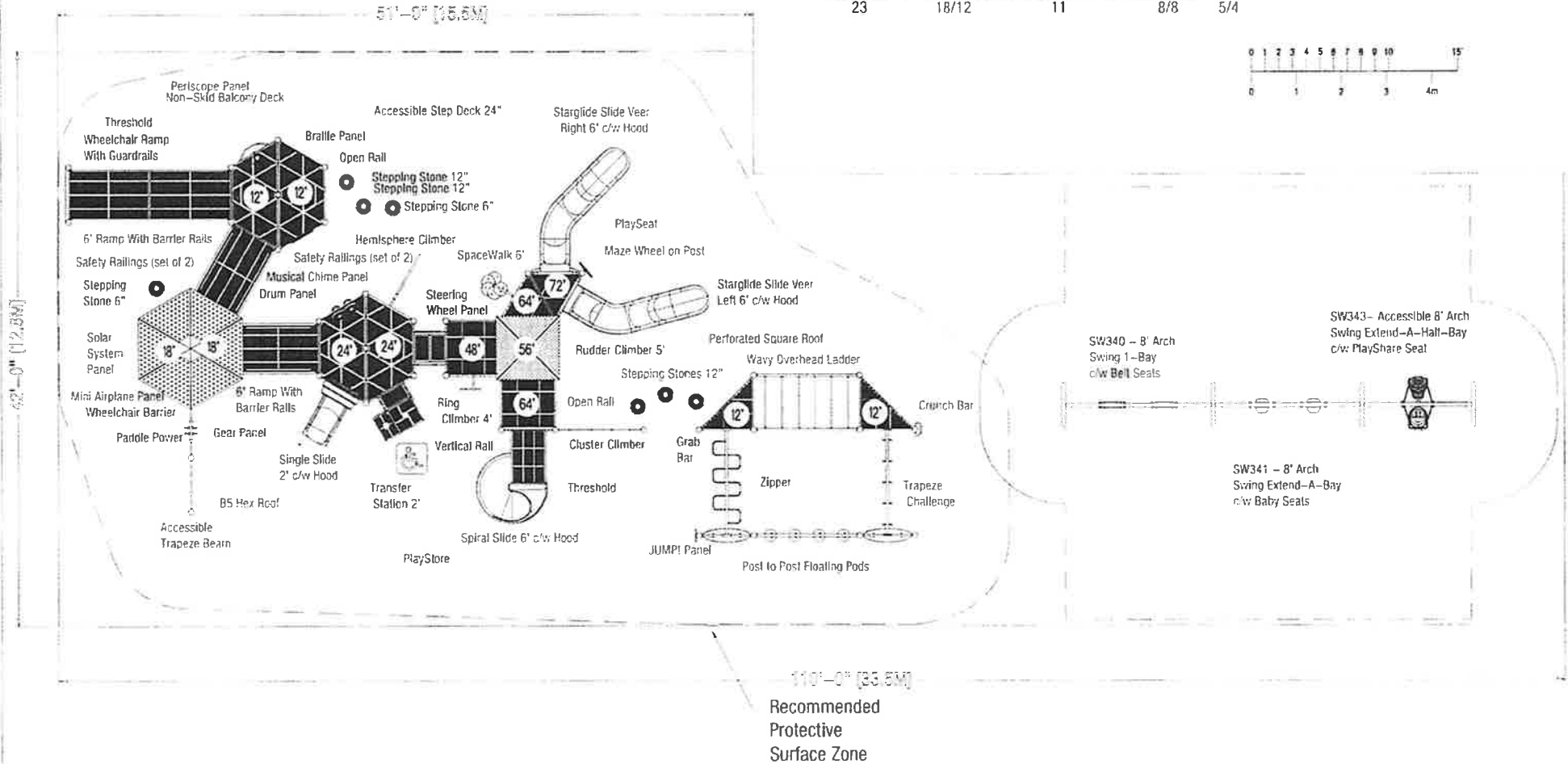
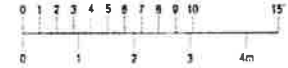

Model No. B502673R1

J. Oliver Construction
Cody Park

Henderson Recreation Equipment Ltd.
PO Box 68, 11 Gilbertson Drive
Simcoe, ON, Canada N3Y 4K5
T: 1.800.265.5462
F: 519.426.9380
www.hendersonplay.ca

Salesperson | A.G.
Drawn By | R.H.
Date Drawn | July 30, 2018
Revised By | R.H.
Revision Date | July 30, 2018

Product Line | Playsteel MAX
Standard Compliance | ASTM F 1487, CPSC
Best User Age | 2 to 12 yrs.
Protective Surfacing Type | Wood Chips
Accessibility | ADA Compliant

Border Area | 4,089 sqm
Border Perimeter | 304'
Installation Type | Inground

WARNING: All play equipment shall have a protective surfacing area that consists of an obstacle free path, resulting in a minimum clear width of 36" (914mm) for all equipment. A 36" (914mm) clear width is required for all equipment. The clear width shall be maintained at all times. See the critical path diagram as specified by the CAN/CSA Z614-14 ASTM F1687 and the U.S. Consumer Product Safety Commission.

POLICY REPORT NO. P&R 07-18
Parks & Recreation Department
Performing Arts Center HVAC Upgrade
Phase III
August 14, 2018

PREPARED BY:

 Steve Grant
 Parks and Recreation Director

REVIEWED BY:

 Paul Kramer
 City Manager

ISSUE:

Review bids received for Performing Arts Center HVAC Upgrades, Phase III.

BACKGROUND:

Due to the inefficiency and unreliability of the HVAC system at the Performing Arts Center, staff identified the need for upgrading the overall heating and cooling systems. During budgetary discussions in the fall of 2015, the decision was made to divide the work into three phases over three years. The first two phases, upgrading the cooling system and replacing the boiler, have been successfully completed in 2016 and 2017 respectively. This third and final phase is to make upgrades and repairs to the air handling unit and the return air tunnel, exhaust systems in the building, and controlled air supply to the southeast corner office.

A bid package was developed and published at local media sites and also posted at Drexel Technologies. A pre-bid meeting was held Friday, July 27, 10:00 a.m. at which time prospective bidders were given access to the Performing Arts Center building. Bids were opened on Friday, August 3, at 2:00 p.m.

Bids were received as follows:

Bidder	Address (City/State)	Base Bid
Engineering Estimate	Leavenworth, KS	\$58,860.00
BCI Mechanical Inc.	Gardner, KS	\$58,004.00
PM Contracting Inc.	Kansas City, MO	\$46,200.00

RECOMMENDATION:

Staff recommends the bid from PM Contracting in the amount not to exceed \$46,200.

BUDGET IMPACT:

There is \$58,860 allocated in the 2018 CIP for this project.

ATTACHMENTS:

PM Contracting Bid Proposal

BID PROPOSAL

(Must either be typewritten or in ink; all others will be rejected)

2018-PAC-HVAC Phase 3

Base Bid - Lump Sum Price – includes all insurance and bond costs, equipment, materials, appurtenances, and labor for the installation of the items as identified in the "Project Scope".

Lump Sum Price: Forty Six Thousand Two Hundred \$ 46,200

PM Contracting Inc. **HEREBY** agrees that the City of Leavenworth has a right to reject any and all bids or parts thereof. The undersigned bidder herewith deposits with the City Clerk the sum of 5% \$ _____ Dollars (Certified check, cashier's check or acceptable bid bond) and makes this bid on the condition and agreement that if said bidder shall fail to enter into a contract to do said work and file good and sufficient bonds as required by law on account of the work awarded to said bidder with the City Clerk within ten (10) working days after said work shall have been awarded to said bidder, that said deposit shall therefore be forfeited to the City of Leavenworth as and for liquidated damages by reason of such failure and that said award may be rescinded and contract awarded to the next lowest responsive bidder.

Completion date to be **Ninety (90) calendar days** after the City Engineer or a duly authorized representative has given "Notice to Proceed" or liquidated damages shall be in accordance with Table 1 in Section 58 of the General Conditions of this document for each calendar day until project completion.

Bidder:	<u>PM Contracting Inc.</u>		
FEIN:	<u>71-0964233</u>		
Address:	<u>15310 Hangar Rd, Kansas City, MO 64147</u>		
By:	<u>Paul Pfannenstiel</u>	Title:	<u>President</u>
Telephone No:	<u>816-318-9844</u>	Fax No:	<u>816-318-9820</u>
Email Address:	<u>paul@pmc-kc.com</u>		

POLICY REPORT PWD NO. 18-33

CONSIDER SOLE SOURCE CONTRACT WITH D'AGOSTINO MECHANICAL
FOR THE 2018 HVAC SYSTEM UPGRADE & REPAIR PROJECT

Project No. 2018-887

August 14, 2018

Prepared by:

Michael G. McDonald, P.E.,
Director of Public Works

Reviewed by:

for Paul Kramer,
City Manager

ISSUE:

Consider approval of the sole source bid received from D'Agostino Mechanical for the 2018 HVAC System Upgrade and Repair Project.

BACKGROUND:

In 2014, the City contracted with KC Mechanical to replace the approximately ten-(10) year old heat exchanger to include a five-(5) year extended warranty for parts and labor. Earlier this year, the replacement heat exchanger started leaking and KC Mechanical was contacted and completed the repair under warranty. Approximately four (4) weeks later, the replacement heat exchanger started leaking and KC Mechanical was contacted with the request to repair the component again. At this time, KC Mechanical refused to do any additional repairs or replacement until additional changes are made to the system, as it is their opinion that the lack of an expansion tank and pressure relief valve on the piping system and a malfunctioning control valve caused the failure of the heat exchanger. The failure in the replacement heat exchanger is different from the failure that prompted the 2014 replacement.

The original system installed with the renovation of City Hall between 2003 and 2005 was designed by an engineer and did not include an expansion tank or relief valve as part of the system. Staff contacted the original design engineer of the mechanical system, Alan Lankford of Lankford Fendler & Assoc., for guidance on the repairs and the original design. Initially Mr. Lankford agreed to assist in resolving the concerns regarding the design of the system.

The system is designed to allow the automatic switch from heating to cooling and/or cooling to heating as is necessary by the thermostat settings and outside temperatures. The issues with the heat exchanger do not allow the system to function as it was designed. With the refusal of KC Mechanical to complete the necessary repairs, City staff contacted D'Agostino Mechanical to make temporary modifications so the system could operate in the cooling mode. Once temporary repairs were made by D'Agostino Mechanical so that the air conditioning would function, Mr. Lankford was no longer interested in assisting the City with the issues.

Pursuing legal action to get KC Mechanical to make additional repairs as part of the warranty were considered, but after a review of the system by John D'Agostino, who is a P.E., I am not confident that course of action would deliver the results we would like, and would likely involve attorney fees as well. Mr. D'Agostino agrees with the opinion that the lack of an expansion tank and relief valve, along with the leaking control valve, are most likely not the cause of the heat exchanger leak, but they could be seen as contributing factors.

After consulting with John D'Agostino P.E., staff is recommending the replacement of the defective heat exchanger, the replacement of the faulty chiller control valve, and the installation of the expansion tank to include a pressure relief valve and air separation valve. This will bring the system more in line with current design criteria and eliminate any additional warranty-related controversy regarding the chiller loop and heat exchanger.

The 2014 project resulted in two (2) bidders, KC Mechanical and D'Agostino Mechanical. KC Mechanical was the low bidder for that project. D'Agostino has diagnosed and resolved several issues for the City at various buildings over the last 15 years, completed numerous quality HVAC projects with the City, and is currently the maintenance contractor for the City Hall system. They have a professional engineer on staff which has proven to be a great asset over the years.

The work must be completed prior to switching the system to the automated function. Equipment delivery is expected to be four (4) to five (5) weeks with installation to be approximately two (2) weeks.

RECOMMENDATION:

Staff recommends that the City Commission approve the sole source bid from D'Agostino Mechanical in the amount of \$38,285.00 to include a five- (5) year parts' warranty.

ATTACHMENTS:

Bid Tab



August 6, 2018

Leavenworth City Hall
 2018 HVAC System Upgrades & Repairs

The goal of this project is Replace the Failed Plate & Frame Heat Exchanger, Upgrade the Chiller Loop System by Adding a System Expansion Tank, Safety Pressure Relief Valve & Add an Air/Dirt Separator. In addition, the Failing Building Loop 3-Way Control Valve serving the Plate & Frame Heat Exchanger shall be Replaced. After installation of all items is completed New Piping & Equipment Insulation shall be Installed on all New Items & a Propylene Glycol Antifreeze mixture will be installed into the Chiller Loop.

All New Systems & Components shall have a full (1) Year Parts & Labor Warranty.

Cost shall not include Kansas Sales Tax, the City will issue a Kansas Project Exemption Certificate for the entire project.

2018 HVAC System Upgrades & Repairs Schedule of Values:

REPLACE PLATE & FRAME HEAT EXCHANGER:	\$ 20,295.00
ADD EXPANSION TANK, ADD SAFETY PRESSURE RELIEF VALVE, ADD AIR/DIRT SEPARATOR, GLYCOL CHILLER LOOP, REPLACE 3-WAY CONTROL VALVE:	\$ 14,550.00
TOTAL:	\$ 34,845.00

**HEAT EXCHANGER ADDITIONAL ADD FOR 4-YEAR
 EXTENDED WARRANTY TOTALING (5) YEAR WARRANTY: \$ 2,865.00**

**3-WAY CONTROL VALVE ADDITIONAL ADD FOR 4-YEAR
 EXTENDED WARRANTY TOTALING (5) YEAR WARRANTY: \$ 575.00**

Submitted By:





Kevin Morley
 Project Manager

POLICY REPORT NO. 18-32 - WPC
Bid Approval – Water Pollution Control (WPC) Division
Tandem Axle Dump Truck

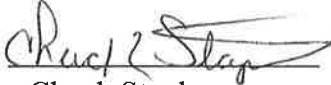
August 14, 2018

Prepared by: 
Chuck Staples
WPC Superintendent

Reviewed by: 
For  Paul Kramer
City Manager

Michael G. McDonald P.E.
Public Works Director

Issue:

Consider approval the purchase of a New Tandem Axle dump truck with 201 stainless steel dump body and hydraulics for snow plow. This project was approved as a 2018 Capital Improvements Project. Both International and Freightliner are members of the National Joint Powers Alliance. (NJPA)

Background:

The City of Leavenworth currently owns two 2005 Sterling tandem axle dump trucks with snow plows. These trucks have over 200,000 miles. The Dump trucks haul dewatered sludge to the landfill four times a week each. A round trip takes two hours and 15 minutes and encompasses 84 miles. Repair costs in 2017 were \$6,241.67 for truck 3364 and \$16,375.97 for truck 3366.

Bids received:	
Vehicle	Amount
2019 INTERNATIONAL MODEL HV507	\$126,556.00
2020 FREIGHTLINER 108SD	\$124,790.00
	(Delivery will be after the first of the year)

Capital Improvements Estimate: \$120,000.00

WPC had discussion with International and Freightliner to discuss the equipment they offered and the equipment needed to build this truck. Both trucks will come with Henderson 201 Stainless steel beds. Both dealers have locations in Kansas City.

NJPA establishes and provides nationally-leveraged and competitively-solicited purchasing contracts under the guidance of uniform Municipal Contracts Law (M.S. 471.345 subdivision 15.

NJPA contracts are awarded at the manufacturer level and sales are made through local dealerships by receiving national volume pricing.

Staff Recommendation:

The Staff recommends the City commission approves the low bid from Kansas City Freightliner Sales for the 2020 Freightliner 108SD Dump Truck at a cost of \$124,790.00.

Options/Alternatives: The City Commission can accept the low bid as recommended by City Staff, or can ask the staff to re-bid.

Attachments:

QUOTATION FORM

Department: WPC

Date of Quote: July 16, 2018

Description of goods or services required: Purchase of new Tandem Axle Dump Truck with 201 Stainless Steel Dump body with hydraulic for snow plow.

Unit of measure: _____

Quantity required: 1

Special requirements (i.e., warranty, ongoing maintenance, timing): Bids are through N.J.P.A. Contact.

Guide to Vendor Contacts for Quotations

DO identify yourself and inform your contact that you are soliciting competitive quotations and will be contacting other potential contractors for similar quotations and that this is their sole chance to price quote for this particular proposed purchase.

DO provide the date by which the quoted item(s) must be delivered to the City receiving point.

DO provide the quantity, unit of measure, a complete description of the item(s) that require pricing and any special considerations and/or requirements that pertain to the procurement.

DO request firm pricing for the required item(s) and ask what credit terms will be extended to the City if an order is placed with their firm.

DO ensure that all contacts are furnishing quotations on equivalent goods or services.

DO NOT contact any one potential contractor more than once for the same quotation or pricing.

DO NOT take a price from a contact and then try to "beat down" their price. The rule is the first price quoted by a given potential contractor is the price by which their quotation shall be evaluated.

DO avoid "price shopping." Price shopping in governmental procurement is an unethical practice that involves taking pricing from one potential supplier and disclosing those prices to another potential supplier in the hope of receiving a lower price from the second supplier. In effect, one is using the first price to "shop" for better prices. Your contacts have the right to expect, and you have an obligation to provide, price confidentiality of all quoted prices until the quotation is awarded.

DO NOT, under any circumstances, become abusive or argumentative with your contacts. Such conduct leads to negative supplier relationships and reflects poorly upon you and the City.

DO thank the contact for their quotation and inform them their firm will be notified by an official City purchase order if their quotation is the lowest price full meeting the requirements of the quotation.

Vendor: Kansas City Freightliner Sales

Vendor address: 7800 NE 38th St. Kansas City, MO 64161

Vendor Representative: Ryan Huff Telephone: (816) 453-4400

Unit Price: \$86,265.00 Extended Price: N/A

Other charges: \$38,525.00 (dump bed) Total Price: \$124,790.00

Other information: Dump bed is a Henderson 201 Stainless Steel bed.

Vendor: Summit Truck Group

Vendor address: 7700 NE 38th St. Kansas City, MO 64161

Vendor Representative: Howard Gentry Telephone: (816) 455-1833

Unit Price: \$88,031.00 Extended Price: N/A

Other charges: \$38,525.00 Total Price: \$126,556.00

Other information: Dump bed is a Henderson 201 Stainless Steel bed.

Vendor: _____

Vendor address: _____

Vendor Representative: _____ Telephone: _____

Unit Price: _____ Extended Price: _____

Other charges (i.e., shipping): _____ Total Price: _____

Other information: _____

Vendor selected: Kansas City Freightliner Sales (delivery will be early 2019)

If vendor selected was not the low quotation, explain rationale for choice (and review page 7 of the manual regarding the 1% preference to local vendors): _____

Performed by: _____

Approved by: _____



Rec'd 7-23-18

History (Cost Summary)

1/1/2017 - 12/31/2017

Innovative Maintenance Systems

CITY OF LEAVENWORTH GARAGE WPC DEPARTMENT WASTE WATER PLANT

Equipment	PM Cost	Repair Cost	Parts Cost	Labor Cost	Tax	Custom Cost	CPM/Km/Hr	Total Cost
3364 - 2006 STERLING LT8500	\$382.47	\$5,822.56	\$4,704.47	\$1,537.20	\$0.00	\$0.00	\$0.34	\$6,241.67
Category Subtotal -	\$382.47	\$5,822.56	\$4,704.47	\$1,537.20	\$0.00	\$0.00		\$6,241.67
Grand Totals:	\$382.47	\$5,822.56	\$4,704.47	\$1,537.20	\$0.00	\$0.00		\$6,241.67

Rec'd 7-23-18

History (Cost Summary)

1/1/2017 - 12/31/2017

Innovative Maintenance Systems

\CITY OF LEAVENWORTH GARAGE\WPC DEPARTMENT\WASTE WATER PLANT

Equipment	PM Cost	Repair Cost	Parts Cost	Labor Cost	Tax	Custom Cost	CPM/Km/Hr	Total Cost
3366 - 2006 STERLING LT8500	\$1,709.21	\$14,666.74	\$13,064.83	\$3,311.12	\$0.00	\$0.00	\$1.11	\$16,375.97
Category Subtotal -	\$1,709.21	\$14,666.74	\$13,064.83	\$3,311.12	\$0.00	\$0.00		\$16,375.97
Grand Totals:	\$1,709.21	\$14,666.74	\$13,064.83	\$3,311.12	\$0.00	\$0.00		\$16,375.97

Prepared for:
Chuck Staples
City of Leavenworth
100 N 5th St
City Hall
Leavenworth, KS 66048
Phone: (913) 306-2735

Prepared by:
Ryan Huff
KANSAS CITY FREIGHTLINER
SALES
7800 N.E. 38TH STREET
KANSAS CITY, MO 64161
Phone: 816-453-4400

A proposal for
City of Leavenworth

Prepared by
KANSAS CITY FREIGHTLINER SALES
Ryan Huff

Jun 28, 2018

2020 Freightliner 108SD

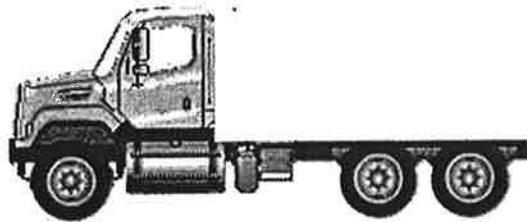

Components shown may not reflect all spec'd options and are not to scale

Application Version 10.1.002
Data Version PRL-18D.010
City of Leavenworth Waste Water TA
Dump Truck



06/28/2018 7:35 AM

Page 1 of 17

Prepared for:
 Chuck Staples
 City of Leavenworth
 100 N 5th St
 City Hall
 Leavenworth, KS 66048
 Phone: (913) 306-2735

Prepared by:
 Ryan Huff
 KANSAS CITY FREIGHTLINER
 SALES
 7800 N.E. 38TH STREET
 KANSAS CITY, MO 64161
 Phone: 816-453-4400

S P E C I F I C A T I O N P R O P O S A L

Data Code	Description	Weight Front	Weight Rear
Price Level			
PRL-18D	SD PRL-18D (EFF:04/17/18)		
Data Version			
DRL-010	SPECPRO21 DATA RELEASE VER 010		
Vehicle Configuration			
001-176	108SD CONVENTIONAL CHASSIS	6,829	3,748
004-219	2019 MODEL YEAR SPECIFIED		
002-004	SET BACK AXLE - TRUCK		
019-002	STRAIGHT TRUCK PROVISION		
003-001	LH PRIMARY STEERING LOCATION		
General Service			
AA1-002	TRUCK CONFIGURATION		
AA6-002	DOMICILED, USA (EXCLUDING CALIFORNIA AND CARB OPT-IN STATES)		
A85-001	REFUSE SERVICE		
A84-1GM	GOVERNMENT BUSINESS SEGMENT		
AA4-013	MOIST BULK COMMODITY		
AA5-006	TERRAIN/DUTY: 10% (SOME) OF THE TIME, IN TRANSIT, IS SPENT ON NON-PAVED ROADS		
AB1-008	MAXIMUM 8% EXPECTED GRADE		
AB5-003	MAINTAINED GRAVEL OR CRUSHED ROCK - MOST SEVERE IN-TRANSIT (BETWEEN SITES) ROAD SURFACE		
995-1A0	FREIGHTLINER SD VOCATIONAL WARRANTY		
A66-99D	EXPECTED FRONT AXLE(S) LOAD : 18000.0 lbs		
A68-99D	EXPECTED REAR DRIVE AXLE(S) LOAD : 40000.0 lbs		
A63-99D	EXPECTED GROSS VEHICLE WEIGHT CAPACITY : 58000.0 lbs		
Truck Service			
AA3-004	END DUMP BODY		

Application Version 10.1.002
 Data Version PRL-18D.010
 City of Leavenworth Waste Water TA
 Dump Truck



06/28/2018 7:35 AM

Page 2 of 17

Prepared for:
 Chuck Staples
 City of Leavenworth
 100 N 5th St
 City Hall
 Leavenworth, KS 66048
 Phone: (913) 306-2735

Prepared by:
 Ryan Huff
 KANSAS CITY FREIGHTLINER
 SALES
 7800 N.E. 38TH STREET
 KANSAS CITY, MO 64161
 Phone: 816-453-4400

Data Code	Description	Weight Front	Weight Rear
A88-99D	EXPECTED TRUCK BODY LENGTH : 15.0 ft		
AF3-1W0	HENDERSON		
Engine			
101-22T	CUM L9 350 HP @ 2000 RPM, 2200 GOV RPM, 1150 LB/FT @ 1400 RPM		
Electronic Parameters			
79A-075	75 MPH ROAD SPEED LIMIT		
79B-000	CRUISE CONTROL SPEED LIMIT SAME AS ROAD SPEED LIMIT		
79M-001	PTO MODE BRAKE OVERRIDE - SERVICE BRAKE APPLIED		
79P-002	PTO RPM WITH CRUISE SET SWITCH - 700 RPM		
79Q-003	PTO RPM WITH CRUISE RESUME SWITCH - 800 RPM		
79S-001	PTO MODE CANCEL VEHICLE SPEED - 5 MPH		
79U-007	PTO GOVERNOR RAMP RATE - 250 RPM PER SECOND		
80G-002	PTO MINIMUM RPM - 700		
80J-002	REGEN INHIBIT SPEED THRESHOLD - 5 MPH		
Engine Equipment			
99C-017	2016 ONBOARD DIAGNOSTICS/2010 EPA/CARB/FINAL GHG17 CONFIGURATION		
99D-010	NO 2008 CARB EMISSION CERTIFICATION		
13E-001	STANDARD OIL PAN		
105-001	ENGINE MOUNTED OIL CHECK AND FILL		
014-099	SIDE OF HOOD AIR INTAKE WITH FIREWALL MOUNTED DONALDSON AIR CLEANER		
124-1D7	DR 12V 160 AMP 28-SI QUADRAMOUNT PAD ALTERNATOR WITH REMOTE BATTERY VOLT SENSE		
292-071	(3) ALLIANCE MODEL 1231XOE, GROUP 31, 12 VOLT MAINTENANCE FREE 3375 CCA THREADED STUD BATTERIES	40	20
290-017	BATTERY BOX FRAME MOUNTED		
281-001	STANDARD BATTERY JUMPERS		
282-003	SINGLE BATTERY BOX FRAME MOUNTED LH SIDE BACK OF CAB		
291-017	WIRE GROUND RETURN FOR BATTERY CABLES WITH ADDITIONAL FRAME GROUND RETURN		
289-001	NON-POLISHED BATTERY BOX COVER		
87P-998	NO CAB AUXILIARY POWER WIRING		



Prepared for:
 Chuck Staples
 City of Leavenworth
 100 N 5th St
 City Hall
 Leavenworth, KS 66048
 Phone: (913) 306-2735

Prepared by:
 Ryan Huff
 KANSAS CITY FREIGHTLINER
 SALES
 7800 N.E. 38TH STREET
 KANSAS CITY, MO 64161
 Phone: 816-453-4400

Data Code	Description	Weight Front	Weight Rear
293-058	POSITIVE LOAD DISCONNECT WITH CAB MOUNTED CONTROL SWITCH MOUNTED OUTBOARD DRIVER SEAT	8	
107-032	CUMMINS TURBOCHARGED 18.7 CFM AIR COMPRESSOR WITH INTERNAL SAFETY VALVE		
152-041	ELECTRONIC ENGINE INTEGRAL SHUTDOWN PROTECTION SYSTEM		
128-076	CUMMINS EXHAUST BRAKE INTEGRAL WITH VARIABLE GEOMETRY TURBO WITH ON/OFF DASH SWITCH	20	
016-1C3	RH OUTBOARD UNDER STEP MOUNTED HORIZONTAL AFTERTREATMENT SYSTEM ASSEMBLY WITH RH HORIZONTAL TAILPIPE		
28F-002	ENGINE AFTERTREATMENT DEVICE, AUTOMATIC OVER THE ROAD REGENERATION AND DASH MOUNTED REGENERATION REQUEST SWITCH		
239-001	STANDARD EXHAUST SYSTEM LENGTH		
237-052	RH STANDARD HORIZONTAL TAILPIPE		
23U-002	13 GALLON DIESEL EXHAUST FLUID TANK		
30N-003	100 PERCENT DIESEL EXHAUST FLUID FILL		
23Y-001	STANDARD DIESEL EXHAUST FLUID PUMP MOUNTING		
43X-002	LH MEDIUM DUTY STANDARD DIESEL EXHAUST FLUID TANK LOCATION		
43Y-001	STANDARD DIESEL EXHAUST FLUID TANK CAP		
273-018	HORTON DRIVEMASTER ADVANTAGE ON/OFF FAN DRIVE		
276-001	AUTOMATIC FAN CONTROL WITHOUT DASH SWITCH, NON ENGINE MOUNTED		
110-003	CUMMINS SPIN ON FUEL FILTER		
118-008	COMBINATION FULL FLOW/BYPASS OIL FILTER		
266-104	1115 SQUARE INCH ALUMINUM RADIATOR		
103-039	ANTIFREEZE TO -34F, OAT (NITRITE AND SILICATE FREE) EXTENDED LIFE COOLANT		
171-007	GATES BLUE STRIPE COOLANT HOSES OR EQUIVALENT		
172-001	CONSTANT TENSION HOSE CLAMPS FOR COOLANT HOSES		
270-016	RADIATOR DRAIN VALVE		
360-016	1310 ADAPTER FLANGE FOR FRONT PTO PROVISION	10	
138-011	PHILLIPS-TEMRO 1000 WATT/115 VOLT BLOCK HEATER	4	



Prepared for:
 Chuck Staples
 City of Leavenworth
 100 N 5th St
 City Hall
 Leavenworth, KS 66048
 Phone: (913) 306-2735

Prepared by:
 Ryan Huff
 KANSAS CITY FREIGHTLINER
 SALES
 7800 N.E. 38TH STREET
 KANSAS CITY, MO 64161
 Phone: 816-453-4400

Data Code	Description	Weight Front	Weight Rear
140-053	BLACK PLASTIC ENGINE HEATER RECEPTACLE MOUNTED UNDER LH DOOR		
132-004	ELECTRIC GRID AIR INTAKE WARMER		
155-058	DELCO 12V 38MT HD STARTER WITH INTEGRATED MAGNETIC SWITCH		
Transmission			
342-582	ALLISON 3000 RDS AUTOMATIC TRANSMISSION WITH PTO PROVISION		
Transmission Equipment			
343-312	ALLISON VOCATIONAL PACKAGE 142 - AVAILABLE ON 3000/4000 PRODUCT FAMILIES WITH VOCATIONAL MODEL RDS		
84B-013	ALLISON VOCATIONAL RATING FOR REFUSE APPLICATIONS AVAILABLE WITH ALL PRODUCT FAMILIES		
84C-023	PRIMARY MODE GEARS, LOWEST GEAR 1, START GEAR 1, HIGHEST GEAR 6, AVAILABLE FOR 3000/4000 PRODUCT FAMILIES ONLY		
84D-023	SECONDARY MODE GEARS, LOWEST GEAR 1, START GEAR 1, HIGHEST GEAR 6, AVAILABLE FOR 3000/4000 PRODUCT FAMILIES ONLY		
84E-000	PRIMARY SHIFT SCHEDULE RECOMMENDED BY DTNA AND ALLISON, THIS DEFINED BY ENGINE AND VOCATIONAL USAGE		
84F-000	SECONDARY SHIFT SCHEDULE RECOMMENDED BY DTNA AND ALLISON, THIS DEFINED BY ENGINE AND VOCATIONAL USAGE		
84G-000	PRIMARY SHIFT SPEED RECOMMENDED BY DTNA AND ALLISON, THIS DEFINED BY ENGINE AND VOCATIONAL USAGE		
84H-000	SECONDARY SHIFT SPEED RECOMMENDED BY DTNA AND ALLISON, THIS DEFINED BY ENGINE AND VOCATIONAL USAGE		
84L-000	LOAD BASED SHIFT SCHEDULE AND VEHICLE ACCELERATION CONTROL RECOMMENDED BY DTNA AND ALLISON, THIS DEFINED VOCATIONAL USAGE		
84N-000	NEUTRAL AT STOP - DISABLED, FUELSENSE - DISABLED		
84U-000	DRIVER SWITCH INPUT - DEFAULT - NO SWITCHES		
84V-001	DIRECTION CHANGE ENABLED WITH MULTIPLEXED SERVICE BRAKES - ALLISON 5TH GEN TRANSMISSIONS		



Prepared for:
 Chuck Staples
 City of Leavenworth
 100 N 5th St
 City Hall
 Leavenworth, KS 66048
 Phone: (913) 306-2735

Prepared by:
 Ryan Huff
 KANSAS CITY FREIGHTLINER
 SALES
 7800 N.E. 38TH STREET
 KANSAS CITY, MO 64161
 Phone: 816-453-4400

Data Code	Description	Weight Front	Weight Rear
353-002	VEHICLE INTERFACE WIRING CONNECTOR WITHOUT BLUNT CUTS, AT FIREWALL		
34C-001	ELECTRONIC TRANSMISSION CUSTOMER ACCESS CONNECTOR FIREWALL MOUNTED		
362-035	CUSTOMER INSTALLED CHELSEA 277 SERIES PTO		
363-001	PTO MOUNTING, LH SIDE OF MAIN TRANSMISSION		
341-018	MAGNETIC PLUGS, ENGINE DRAIN, TRANSMISSION DRAIN, AXLE(S) FILL AND DRAIN		
345-003	PUSH BUTTON ELECTRONIC SHIFT CONTROL, DASH MOUNTED		
97G-004	TRANSMISSION PROGNOSTICS - ENABLED 2013		
370-015	WATER TO OIL TRANSMISSION COOLER, IN RADIATOR END TANK		
346-003	TRANSMISSION OIL CHECK AND FILL WITH ELECTRONIC OIL LEVEL CHECK		
35T-001	SYNTHETIC TRANSMISSION FLUID (TES-295 COMPLIANT)		

Front Axle and Equipment

400-1BA	DETROIT DA-F-18.0-5 18,000# FL1 71.0 KPI/3.74 DROP SINGLE FRONT AXLE	210	
402-030	MERITOR 16.5X6 Q+ CAST SPIDER CAM FRONT BRAKES, DOUBLE ANCHOR, FABRICATED SHOES	10	
403-002	NON-ASBESTOS FRONT BRAKE LINING		
419-023	CONMET CAST IRON FRONT BRAKE DRUMS		
409-006	FRONT OIL SEALS		
408-001	VENTED FRONT HUB CAPS WITH WINDOW, CENTER AND SIDE PLUGS - OIL		
416-022	STANDARD SPINDLE NUTS FOR ALL AXLES		
405-002	MERITOR AUTOMATIC FRONT SLACK ADJUSTERS		
406-001	STANDARD KING PIN BUSHINGS		
536-012	TRW TAS-85 POWER STEERING	40	
539-003	POWER STEERING PUMP		
534-015	2 QUART SEE THROUGH POWER STEERING RESERVOIR		
533-001	OIL/AIR POWER STEERING COOLER	5	
40T-002	SYNTHETIC 75W-90 FRONT AXLE LUBE		

Front Suspension

Application Version 10.1.002
 Data Version PRL-18D.010
 City of Leavenworth Waste Water TA
 Dump Truck



06/28/2018 7:35 AM

Page 6 of 17

Prepared for:
 Chuck Staples
 City of Leavenworth
 100 N 5th St
 City Hall
 Leavenworth, KS 66048
 Phone: (913) 306-2735

Prepared by:
 Ryan Huff
 KANSAS CITY FREIGHTLINER
 SALES
 7800 N.E. 38TH STREET
 KANSAS CITY, MO 64161
 Phone: 816-453-4400

Data Code	Description	Weight Front	Weight Rear
620-005	18,000# FLAT LEAF FRONT SUSPENSION	290	
619-004	GRAPHITE BRONZE BUSHINGS WITH SEALS - FRONT SUSPENSION		
410-001	FRONT SHOCK ABSORBERS		
Rear Axle and Equipment			
420-1K4	MT-40-14XP 40,000# R-SERIES TANDEM REAR AXLE		2,530
421-529	5.29 REAR AXLE RATIO		
424-003	IRON REAR AXLE CARRIER WITH OPTIONAL HEAVY DUTY AXLE HOUSING		40
386-073	MXL 17T MERITOR EXTENDED LUBE MAIN DRIVELINE WITH HALF ROUND YOKES	20	20
388-073	MXL 17T MERITOR EXTENDED LUBE INTERAXLE DRIVELINE WITH HALF ROUND YOKES		
452-005	DRIVER CONTROLLED TRACTION DIFFERENTIAL - REAR MOST TANDEM/TRIDEM REAR AXLE		20
878-021	(1) INTERAXLE LOCK VALVE AND (1) DRIVER CONTROLLED DIFFERENTIAL LOCK REAR-REAR AXLE VALVE		
87A-001	BLINKING LAMP WITH EACH INTERAXLE LOCK SWITCH, INTERAXLE UNLOCK DEFAULT WITH IGNITION OFF		
87B-004	BLINKING LAMP WITH EACH MODE SWITCH, DIFFERENTIAL UNLOCK WITH IGNITION OFF, ACTIVE <5 MPH		
423-020	MERITOR 16.5X7 Q+ CAST SPIDER CAM REAR BRAKES, DOUBLE ANCHOR, FABRICATED SHOES		
433-002	NON-ASBESTOS REAR BRAKE LINING		
434-011	BRAKE CAMS AND CHAMBERS ON FORWARD SIDE OF DRIVE AXLE(S)		
451-023	CONMET CAST IRON REAR BRAKE DRUMS		
440-006	REAR OIL SEALS		
426-101	WABCO TRISTOP D LONGSTROKE 2-DRIVE AXLE SPRING PARKING CHAMBERS		20
428-003	HALDEX AUTOMATIC REAR SLACK ADJUSTERS		
41T-002	SYNTHETIC 75W-90 REAR AXLE LUBE		
42T-001	STANDARD REAR AXLE BREATHER(S)		
Rear Suspension			
622-1A0	TUFTRAC 40,000# REAR SPRING SUSPENSION		410
621-055	TUFTRAC STANDARD RIDE HEIGHT		



Prepared for:
 Chuck Staples
 City of Leavenworth
 100 N 5th St
 City Hall
 Leavenworth, KS 66048
 Phone: (913) 306-2735

Prepared by:
 Ryan Huff
 KANSAS CITY FREIGHTLINER
 SALES
 7800 N.E. 38TH STREET
 KANSAS CITY, MO 64161
 Phone: 816-453-4400

Data Code	Description	Weight Front	Weight Rear
431-003	AXLE CLAMPING GROUP		
624-009	54 INCH AXLE SPACING		
623-006	FORE/AFT AND TRANSVERSE CONTROL RODS		
439-001	REAR SHOCK ABSORBERS - ONE AXLE		
Brake System			
490-100	WABCO 4S/4M ABS WITHOUT TRACTION CONTROL		
871-001	REINFORCED NYLON, FABRIC BRAID AND WIRE BRAID CHASSIS AIR LINES		
904-001	FIBER BRAID PARKING BRAKE HOSE		
412-001	STANDARD BRAKE SYSTEM VALVES		
46D-002	STANDARD AIR SYSTEM PRESSURE PROTECTION SYSTEM		
413-002	STD U.S. FRONT BRAKE VALVE		
432-003	RELAY VALVE WITH 5-8 PSI CRACK PRESSURE, NO REAR PROPORTIONING VALVE		
480-088	WABCO SYSTEM SAVER HP WITH INTEGRAL AIR GOVERNOR AND HEATER		
483-004	WABCO OIL COALESCING FILTER FOR AIR DRYER		
479-003	AIR DRYER MOUNTED INBOARD ON LH RAIL		
460-001	STEEL AIR BRAKE RESERVOIRS		
607-001	CLEAR FRAME RAILS FROM BACK OF CAB TO FRONT REAR SUSPENSION BRACKET, BOTH RAILS OUTBOARD		
477-004	PULL CABLES ON ALL AIR RESERVOIR(S)		
Trailer Connections			
335-004	UPGRADED CHASSIS MULTIPLEXING UNIT		
Wheelbase & Frame			
545-502	5025MM (198 INCH) WHEELBASE		
546-101	11/32X3-1/2X10-15/16 INCH STEEL FRAME (8.73MMX277.8MM/0.344X10.94 INCH) 120KSI	280	-30
547-001	1/4 INCH (6.35MM) C-CHANNEL INNER FRAME REINFORCEMENT	180	370
548-803	BODY COMPANY INSTALLED ADDITIONAL FRONT FRAME REINFORCEMENT FOR SNOW PLOW		
552-014	1900MM (75 INCH) REAR FRAME OVERHANG		
55W-007	FRAME OVERHANG RANGE: 71 INCH TO 80 INCH	-30	120



Prepared for:
 Chuck Staples
 City of Leavenworth
 100 N 5th St
 City Hall
 Leavenworth, KS 66048
 Phone: (913) 306-2735

Prepared by:
 Ryan Huff
 KANSAS CITY FREIGHTLINER
 SALES
 7800 N.E. 38TH STREET
 KANSAS CITY, MO 64161
 Phone: 816-453-4400

Data Code	Description	Weight Front	Weight Rear
AC8-99D	CALC'D BACK OF CAB TO REAR SUSP C/L (CA) : 132.45 in		
AE8-99D	CALCULATED EFFECTIVE BACK OF CAB TO REAR SUSPENSION C/L (CA) : 129.45 in		
AE4-99D	CALC'D FRAME LENGTH - OVERALL : 311.97		
AM6-99D	CALC'D SPACE AVAILABLE FOR DECKPLATE : 132.45 in		
FSS-0LH	CALCULATED FRAME SPACE LH SIDE : 40.1 in		
FSS-0RH	CALCULATED FRAME SPACE RH SIDE : 109.34 in		
553-001	SQUARE END OF FRAME		
550-001	FRONT CLOSING CROSSMEMBER		
559-003	LIGHTWEIGHT HEAVY DUTY ALUMINUM ENGINE CROSSMEMBER	-12	
562-001	STANDARD MIDSHIP #1 CROSSMEMBER(S)		
572-001	STANDARD REARMOST CROSSMEMBER		
565-002	HEAVY DUTY SUSPENSION CROSSMEMBER		30
Chassis Equipment			
556-1E7	14 INCH PAINTED STEEL SEVERE DUTY BUMPER	130	-15
558-001	FRONT TOW HOOKS - FRAME MOUNTED	15	
574-001	BUMPER MOUNTING FOR SINGLE LICENSE PLATE		
551-007	GRADE 8 THREADED HEX HEADED FRAME FASTENERS		
Fuel Tanks			
204-154	80 GALLON/302 LITER ALUMINUM FUEL TANK - LH	10	
218-006	25 INCH DIAMETER FUEL TANK(S)		
215-005	PLAIN ALUMINUM/PAINTED STEEL FUEL/HYDRAULIC TANK(S) WITH PAINTED BANDS		
212-007	FUEL TANK(S) FORWARD		
664-001	PLAIN STEP FINISH		
205-001	FUEL TANK CAP(S)		
122-1J1	DETROIT FUEL/WATER SEPARATOR WITH WATER IN FUEL SENSOR, HAND PRIMER AND 12 VOLT PREHEATER"	-5	
216-020	EQUIFLO INBOARD FUEL SYSTEM		
11F-998	NO NATURAL GAS VEHICLE FUEL TANK VENT LINE/STACK		



Prepared for:
 Chuck Staples
 City of Leavenworth
 100 N 5th St
 City Hall
 Leavenworth, KS 66048
 Phone: (913) 306-2735

Prepared by:
 Ryan Huff
 KANSAS CITY FREIGHTLINER
 SALES
 7800 N.E. 38TH STREET
 KANSAS CITY, MO 64161
 Phone: 816-453-4400

Data Code	Description	Weight Front	Weight Rear
202-016	HIGH TEMPERATURE REINFORCED NYLON FUEL LINE		
Tires			
093-1RJ	MICHELIN X WORKS Z 315/80R22.5 20 PLY RADIAL FRONT TIRES	100	
094-2F6	CONTINENTAL HDR2 11R22.5 14 PLY RADIAL REAR TIRES		184
Hubs			
418-060	CONMET PRESET PLUS PREMIUM IRON FRONT HUBS		
450-060	CONMET PRESET PLUS PREMIUM IRON REAR HUBS		
Wheels			
502-433	ACCURIDE 29039 22.5X9.00 10-HUB PILOT 5.25 INSET 5-HAND STEEL DISC FRONT WHEELS	66	
505-428	ACCURIDE 28828 22.5X8.25 10-HUB PILOT 2-HAND HD STEEL DISC REAR WHEELS		104
Cab Exterior			
829-1A5	108 INCH BBC FLAT ROOF ALUMINUM CONVENTIONAL CAB		
650-008	AIR CAB MOUNTING		
648-002	NONREMOVABLE BUGSCREEN MOUNTED BEHIND GRILLE		
667-037	SHORT FENDER WITH MUDFLAP		
678-001	LH AND RH GRAB HANDLES		
646-041	STATIONARY BLACK GRILLE		
65X-004	BLACK HOOD MOUNTED AIR INTAKE GRILLE		
644-004	FIBERGLASS HOOD		
727-1AF	SINGLE 14 INCH ROUND HADLEY AIR HORN UNDER LH DECK		
726-001	SINGLE ELECTRIC HORN		
728-001	SINGLE HORN SHIELD		
657-1CV	DOOR LOCKS AND IGNITION SWITCH KEYED THE SAME WITH (4) KEYS		
575-001	REAR LICENSE PLATE MOUNT END OF FRAME		
312-068	HALOGEN COMPOSITE HEADLAMPS WITH BLACK BEZELS		
302-047	LED AERODYNAMIC MARKER LIGHTS		
294-1AY	INTEGRAL LED STOP/TAIL/BACKUP LIGHTS		
300-015	STANDARD FRONT TURN SIGNAL LAMPS		



Prepared for:
 Chuck Staples
 City of Leavenworth
 100 N 5th St
 City Hall
 Leavenworth, KS 66048
 Phone: (913) 306-2735

Prepared by:
 Ryan Huff
 KANSAS CITY FREIGHTLINER
 SALES
 7800 N.E. 38TH STREET
 KANSAS CITY, MO 64161
 Phone: 816-453-4400

Data Code	Description	Weight Front	Weight Rear
744-1BG	DUAL WEST COAST MOLDED-IN COLOR HEATED MIRRORS		
797-001	DOOR MOUNTED MIRRORS		
796-001	102 INCH EQUIPMENT WIDTH		
743-1AP	LH AND RH 8 INCH MOLDED-IN COLOR CONVEX MIRRORS MOUNTED UNDER PRIMARY MIRRORS		
729-001	STANDARD SIDE/REAR REFLECTORS		
768-043	63X14 INCH TINTED REAR WINDOW		
661-004	TINTED DOOR GLASS LH AND RH WITH TINTED OPERATING WING WINDOWS		
654-003	MANUAL DOOR WINDOW REGULATORS		
663-013	TINTED WINDSHIELD		
659-007	8 LITER WINDSHIELD WASHER RESERVOIR, CAB MOUNTED, WITHOUT FLUID LEVEL INDICATOR		

Cab Interior

707-1AK	OPAL GRAY VINYL INTERIOR
706-013	MOLDED PLASTIC DOOR PANEL
708-013	MOLDED PLASTIC DOOR PANEL
772-006	BLACK MATS WITH SINGLE INSULATION
785-998	NO DASH MOUNTED ASH TRAYS AND LIGHTER
691-008	FORWARD ROOF MOUNTED CONSOLE WITH UPPER STORAGE COMPARTMENTS WITHOUT NETTING
694-010	IN DASH STORAGE BIN
742-007	(2) CUP HOLDERS LH AND RH DASH
680-006	GRAY/CHARCOAL FLAT DASH
860-004	SMART SWITCH EXPANSION MODULE
700-002	HEATER, DEFROSTER AND AIR CONDITIONER
701-001	STANDARD HVAC DUCTING
703-005	MAIN HVAC CONTROLS WITH RECIRCULATION SWITCH
170-015	STANDARD HEATER PLUMBING
130-033	DENSO HEAVY DUTY AIR CONDITIONER COMPRESSOR
702-002	BINARY CONTROL, R-134A
739-033	STANDARD INSULATION
285-013	SOLID-STATE CIRCUIT PROTECTION AND FUSES
280-007	12V NEGATIVE GROUND ELECTRICAL SYSTEM



Prepared for:
 Chuck Staples
 City of Leavenworth
 100 N 5th St
 City Hall
 Leavenworth, KS 66048
 Phone: (913) 306-2735

Prepared by:
 Ryan Huff
 KANSAS CITY FREIGHTLINER
 SALES
 7800 N.E. 38TH STREET
 KANSAS CITY, MO 64161
 Phone: 816-453-4400

Data Code	Description	Weight Front	Weight Rear
324-014	DOMES LIGHT WITH 3-WAY SWITCH ACTIVATED BY LH AND RH DOORS		
655-001	CAB DOOR LATCHES WITH MANUAL DOOR LOCKS		
284-045	(2) 12 VOLT POWER RECEPTACLES MOUNTED IN DASH		
756-1J3	BASIC HIGH BACK AIR SUSPENSION DRIVER SEAT WITH MECHANICAL LUMBAR AND INTEGRATED CUSHION EXTENSION	30	
760-1J3	BASIC HIGH BACK AIR SUSPENSION PASSENGER SEAT WITH MECHANICAL LUMBAR AND INTEGRATED CUSHION EXTENSION	25	10
759-007	DUAL DRIVER SEAT ARMRESTS, NO PASSENGER SEAT ARMRESTS	4	
711-004	LH AND RH INTEGRAL DOOR PANEL ARMRESTS		
758-022	BLACK MORDURA CLOTH DRIVER SEAT COVER		
761-023	BLACK MORDURA CLOTH PASSENGER SEAT COVER		
763-101	BLACK SEAT BELTS		
532-002	ADJUSTABLE TILT AND TELESCOPING STEERING COLUMN	10	
540-015	4-SPOKE 18 INCH (450MM) STEERING WHEEL		
765-002	DRIVER AND PASSENGER INTERIOR SUN VISORS		

Instruments & Controls

732-004	GRAY DRIVER INSTRUMENT PANEL		
734-004	GRAY CENTER INSTRUMENT PANEL		
870-001	BLACK GAUGE BEZELS		
486-001	LOW AIR PRESSURE INDICATOR LIGHT AND AUDIBLE ALARM		
840-002	2 INCH PRIMARY AND SECONDARY AIR PRESSURE GAUGES		
198-025	INTAKE MOUNTED AIR RESTRICTION INDICATOR WITHOUT GRADUATIONS		
721-025	97 DB BACKUP ALARM MOUNTED INBOARD OF RAIL		3
149-013	ELECTRONIC CRUISE CONTROL WITH SWITCHES IN LH SWITCH PANEL		
156-007	KEY OPERATED IGNITION SWITCH AND INTEGRAL START POSITION; 4 POSITION OFF/RUN/START/ACCESSORY		
811-042	ICU3S, 132X48 DISPLAY WITH DIAGNOSTICS, 28 LED WARNING LAMPS AND DATA LINKED		



Prepared for:
 Chuck Staples
 City of Leavenworth
 100 N 5th St
 City Hall
 Leavenworth, KS 66048
 Phone: (913) 306-2735

Prepared by:
 Ryan Huff
 KANSAS CITY FREIGHTLINER
 SALES
 7800 N.E. 38TH STREET
 KANSAS CITY, MO 64161
 Phone: 816-453-4400

Data Code	Description	Weight Front	Weight Rear
160-038	HEAVY DUTY ONBOARD DIAGNOSTICS INTERFACE CONNECTOR LOCATED BELOW LH DASH		
844-001	2 INCH ELECTRIC FUEL GAUGE		
148-003	PROGRAMMABLE RPM CONTROL - ELECTRONIC ENGINE		
856-001	ELECTRICAL ENGINE COOLANT TEMPERATURE GAUGE		
864-001	2 INCH TRANSMISSION OIL TEMPERATURE GAUGE		
830-017	ENGINE AND TRIP HOUR METERS INTEGRAL WITHIN DRIVER DISPLAY		
372-051	CUSTOMER FURNISHED AND INSTALLED PTO CONTROLS		
852-002	ELECTRIC ENGINE OIL PRESSURE GAUGE		
746-114	AM/FM/WB WORLD TUNER RADIO WITH AUXILIARY INPUT, J1939	10	
747-001	DASH MOUNTED RADIO		
750-002	(2) RADIO SPEAKERS IN CAB		
753-001	AM/FM ANTENNA MOUNTED ON FORWARD LH ROOF		
748-001	POWER AND GROUND STUDS IN/UNDER DASH		
810-027	ELECTRONIC MPH SPEEDOMETER WITH SECONDARY KPH SCALE, WITHOUT ODOMETER		
817-001	STANDARD VEHICLE SPEED SENSOR		
812-001	ELECTRONIC 3000 RPM TACHOMETER		
162-002	IGNITION SWITCH CONTROLLED ENGINE STOP		
81Y-001	PRE-TRIP LAMP INSPECTION, ALL OUTPUTS FLASH, WITH SMART SWITCH		
836-015	DIGITAL VOLTAGE DISPLAY INTEGRAL WITH DRIVER DISPLAY		
660-008	SINGLE ELECTRIC WINDSHIELD WIPER MOTOR WITH DELAY		
304-001	MARKER LIGHT SWITCH INTEGRAL WITH HEADLIGHT SWITCH		
882-018	ONE VALVE PARKING BRAKE SYSTEM WITH DASH VALVE CONTROL AUTONEUTRAL AND WARNING INDICATOR		
299-013	SELF CANCELING TURN SIGNAL SWITCH WITH DIMMER, WASHER/WIPER AND HAZARD IN HANDLE		



Prepared for:
 Chuck Staples
 City of Leavenworth
 100 N 5th St
 City Hall
 Leavenworth, KS 66048
 Phone: (913) 306-2735

Prepared by:
 Ryan Huff
 KANSAS CITY FREIGHTLINER
 SALES
 7800 N.E. 38TH STREET
 KANSAS CITY, MO 64161
 Phone: 816-453-4400

Data Code	Description	Weight Front	Weight Rear
298-039	INTEGRAL ELECTRONIC TURN SIGNAL FLASHER WITH HAZARD LAMPS OVERRIDING STOP LAMPS		

Design

065-000	PAINT: ONE SOLID COLOR		
---------	------------------------	--	--

Color

980-5F6	CAB COLOR A: L0006EB WHITE ELITE BC		
986-020	BLACK, HIGH SOLIDS POLYURETHANE CHASSIS PAINT		
962-972	POWDER WHITE (N0006EA) FRONT WHEELS/RIMS (PKWHT21, TKWHT21, W, TW)		
966-972	POWDER WHITE (N0006EA) REAR WHEELS/RIMS (PKWHT21, TKWHT21, W, TW)		
964-020	STANDARD BLACK BUMPER PAINT		
963-003	STANDARD E COAT/UNDERCOATING		

Certification / Compliance

996-001	U.S. FMVSS CERTIFICATION, EXCEPT SALES CABS AND GLIDER KITS		
---------	--	--	--

Secondary Factory Options

* MWF-005	DETROIT FRONT AXLE COVERAGE, HEAVY SERVICE/SEVERE DUTY, 1 YEAR/UNLIMITED MILES/KM		
-----------	---	--	--

Sales Programs

NO SALES PROGRAMS HAVE BEEN SELECTED

TOTAL VEHICLE SUMMARY

Weight Summary

	Weight Front	Weight Rear	Total Weight
Factory Weight ⁺	8299 lbs	7584 lbs	15883 lbs
Total Weight ⁺	8299 lbs	7584 lbs	15883 lbs



Prepared for:
Chuck Staples
City of Leavenworth
100 N 5th St
City Hall
Leavenworth, KS 66048
Phone: (913) 306-2735

Prepared by:
Ryan Huff
KANSAS CITY FREIGHTLINER
SALES
7800 N.E. 38TH STREET
KANSAS CITY, MO 64161
Phone: 816-453-4400

(+) Weights shown are estimates only.
If weight is critical, contact Customer Application Engineering.



Prepared for:
 Chuck Staples
 City of Leavenworth
 100 N 5th St
 City Hall
 Leavenworth, KS 66048
 Phone: (913) 306-2735

Prepared by:
 Ryan Huff
 KANSAS CITY FREIGHTLINER
 SALES
 7800 N.E. 38TH STREET
 KANSAS CITY, MO 64161
 Phone: 816-453-4400

D I M E N S I O N S

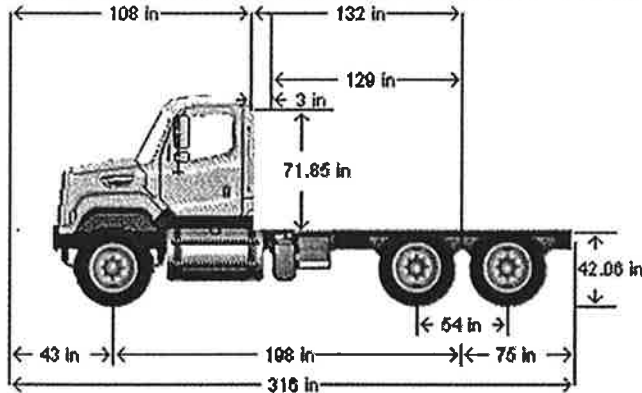

VEHICLE SPECIFICATIONS SUMMARY - DIMENSIONS

Wheelbase (545)	5025MM (198 INCH) WHEELBASE
Rear Frame Overhang (552)	1900MM (75 INCH) REAR FRAME OVERHANG
Fifth Wheel (578)	NO FIFTH WHEEL
Mounting Location (577)	NO FIFTH WHEEL LOCATION
Maximum Forward Position (in)	0
Maximum Rearward Position (in)	0
Amount of Slide Travel (in)	0
Slide Increment (in)	0
Desired Slide Position (in)	0.0
Cab Size (829)	108 INCH BBC FLAT ROOF ALUMINUM CONVENTIONAL CAB
Sleeper (682)	NO SLEEPER BOX/SLEEPER/CAB
Exhaust System (016)	RH OUTBOARD UNDER STEP MOUNTED HORIZONTAL AFTERTREATMENT SYSTEM ASSEMBLY WITH RH HORIZONTAL TAILPIPE

TABLE SUMMARY - DIMENSIONS



Prepared for:
 Chuck Staples
 City of Leavenworth
 100 N 5th St
 City Hall
 Leavenworth, KS 66048
 Phone: (913) 306-2735

Prepared by:
 Ryan Huff
 KANSAS CITY FREIGHTLINER
 SALES
 7800 N.E. 38TH STREET
 KANSAS CITY, MO 64161
 Phone: 816-453-4400

Dimensions	Inches
Bumper to Back of Cab (BBC)	108.5
Bumper to Centerline of Front Axle (BA)	42.9
Min. Cab to Body Clearance (CB)	3.0
Back of Cab to Centerline of Rear Axle(s) (CA)	132.4
Effective Back of Cab to Centerline of Rear Axle(s) (Effective CA)	129.4
Back of Cab Protrusions (Exhaust/Intake) (CP)	0.0
Back of Cab Protrusions (Side Extenders/Trim Tab) (CP)	0.0
Back of Cab Protrusions (CNG Tank)	0.0
Back of Cab Clearance (CL)	3.0
Back of Cab to End of Frame	207.4
Cab Height (CH)	71.9
Wheelbase (WB)	198.0
Frame Overhang (OH)	75.0
Overall Length (OAL)	315.9
Rear Axle Spacing	54.0
Unladen Frame Height at Centerline of Rear Axle	42.1

Performance calculations are estimates only. If performance calculations are critical, please contact Customer Application Engineering.



RETAIL ORDER FOR A MOTOR VEHICLE

June 28, 2018

Date

Kansas City Freightliner

Dealer's Name

7800 NE 38th Street

Street Address

Kansas City MO 64161

City

State/ZIP

Ryan Huff



City of Leavenworth

Customer's Name

Street Address

City

State/ZIP

Fax

Phone

PLEASE ENTER MY ORDER FOR THE FOLLOWING

NEW USED OTHER

YEAR 2020 MAKE Freightliner MODEL 108SD BODY TYPE DAY CAB COLOR WHITE TRIM GRAY

VIN TBD STOCK TBD TO BE DELIVERED ON OR ABOUT 270 Days From Receipt of PO

COST OF VEHICLE	\$86,265.00	EACH	USED VEHICLE TRADE-IN AND/OR OTHER CREDITS
			MAKE OF TRADE-IN
Henderson Quote 113875-13	\$38,525.00		YEAR MODEL BODY
			VIN
			BALANCE OWED TO 0
			ADDRESS
FET EXEMPT	\$0.00		USED TRADE-IN ALLOWANCE \$ -
	\$124,790.00		BALANCE OWED ON TRADE-IN \$ -
Number of Trucks	1		NET ALLOWANCE ON USED TRADE-IN \$ -
Total	\$124,790.00		DEPOSIT OR CREDIT BALANCE
			DOWN PAYMENT (Transfer to Left Column) \$ -
CASH SALE PRICE OF DESCRIBED MOTOR VEHICLE(s)	\$0.00		Per Specification:
			"City of Leavenworth Waste Water TA Dump Truck 06_28_2018"
STATE AND LOCAL TAXES			
LICENSE, LICENSE TRANSFER, TITLE, REGISTRATION FEE			
1. TOTAL PRICE OF UNIT(s)	\$124,790.00		
2. DOWN PAYMENT: consisting of \$ - In cash and/or net trade-in allowance on trade-in; see statement in right hand column for details.			
3. UNPAID CASH BALANCE DUE ON DELIVERY (difference between Items 1 and 2)	\$124,790.00		
			No Dealer Warranty, Expressed or Implied
			Sold in "AS IS" Condition, True Mileage Unknown
			Payment Due Upon Delivery
			Subject to management and financial approval
			Trade Terms

Attention Used Car Buyers: If you are buying a used vehicle with this contract, federal regulations may require a special buyers guide to be displayed on the window of the vehicle. **THE INFORMATION YOU SEE ON THE WINDOW FORM FOR THIS VEHICLE IS PART OF**

ALL WARRANTIES, IF ANY, BY A MANUFACTURER OR SUPPLIER OTHER THAN DEALER ARE THEIRS, NOT THE DEALER'S, AND ONLY SUCH MANUFACTURER OR OTHER SUPPLIER SHALL BE LIABLE FOR PERFORMANCE UNDER SUCH WARRANTIES. UNLESS DEALER FURNISHES BUYER WITH A SEPARATE WRITTE

The front and back of this Order comprise the entire agreement affecting this purchase and no other agreement or understanding of any nature concerning same has been made or entered into, or will be recognized. I hereby certify that no credit has been ex

PURCHASER'S SIGNATURE _____ DATE _____

ACCEPTED BY: _____
DEALER OR HIS AUTHORIZED REPRESENTATIVE

ADDITIONAL TERMS AND CONDITIONS

1. As used in this Order the terms (a) "Dealer" shall mean the authorized Dealer to whom this Order is addressed and who shall become a party hereto by its acceptance hereof, (b) "Purchaser" shall mean the party executing this Order as such on the face hereof, and (c) "Manufacturer" shall mean the Corporation that manufactured the vehicle or chassis, it being understood by the Purchaser and Dealer that Dealer is in no respect the agent of Manufacturer, that Dealer and Purchaser are the sole parties to this Order and that reference to Manufacturer herein is for the purpose of explaining generally certain contractual relationships, existing between Dealer and Manufacturer with respect to new motor vehicles.
2. Manufacturer has reserved the right to change the price to Dealer of new motor vehicles without notice. In the event the price to Dealer of new motor vehicles of the series and body type ordered hereunder is changed by Manufacturer prior to delivery of the new motor vehicle ordered hereunder to Purchaser, Dealer reserves the right to change the cash delivered price of such motor vehicle to Purchaser accordingly. If such cash delivered price is increased by Dealer, Purchaser may, if dissatisfied therewith, cancel this Order.
3. If the used motor vehicle which has been traded in as a part of the consideration for the motor vehicle ordered hereunder is not to be delivered to Dealer until delivery to Purchaser of such motor vehicle, the used motor vehicle shall be reappraised at that time and such reappraised value shall determine the allowance made for such used motor vehicle. If such reappraised value is lower than the original allowance therefore shown on the front of this Order, Purchaser may, if dissatisfied therewith, cancel this Order, provided, however, that such right to cancel is exercised prior to the delivery of the motor vehicle ordered hereunder to the Purchaser and surrender of the used motor vehicle to Dealer.
4. Purchaser agrees to deliver to Dealer satisfactory evidence of title to any used motor vehicle traded in as a part of the consideration for the motor vehicle ordered hereunder at the time of delivery of such used motor vehicle to Dealer. Purchaser warrants any such used motor vehicle to be his property free and clear of all liens and encumbrances except as otherwise noted herein.
5. Manufacturer has reserved the right to change the design of any new motor vehicle, chassis accessories or parts thereof at any time without notice and without obligation to make the same or any similar change upon any motor vehicle, chassis, accessories or parts thereof previously purchased by or shipped to Dealer or being manufactured or sold in accordance with Dealer's orders. Correspondingly, in the event of any such change by Manufacturer, Dealer shall have no obligation to Purchaser to make the same or any similar change in any motor vehicle, chassis, accessories or parts thereof covered by this Order either before or subsequent to delivery thereof to Purchaser.
6. Dealer shall not be liable for failure or delay in delivering the motor vehicle covered by this Order where such failure or delay is due, in whole or in part, to any cause beyond the control or without the fault or negligence of Dealer.
7. The price for the motor vehicle specified on the face of this Order includes reimbursement for Federal Excise taxes, but does not include sales taxes, use taxes or occupational taxes based on sales volume, (Federal, State, or Local) unless expressly so stated. Purchaser assumes and agrees to pay, unless prohibited by law, any such sales, use or occupational taxes imposed on or applicable to the transaction covered by this Order, regardless of which party may have primary tax liability therefore.
8. **FACTORY WARRANTY: ANY WARRANTY ON ANY NEW VEHICLE OR USED VEHICLE STILL SUBJECT TO A MANUFACTURER'S WARRANTY IS THAT MADE BY THE MANUFACTURER ONLY. THE SELLER HEREBY DISCLAIMS ALL WARRANTIES, EITHER EXPRESS OR IMPLIED, INCLUDING ANY IMPLIED WARRANTY OF MERCHANTABILITY OR FITNESS FOR A PARTICULAR PURPOSE.**
USED VEHICLE WHETHER OR NOT SUBJECT TO MANUFACTURER'S WARRANTY: UNLESS A SEPARATE WRITTEN INSTRUMENT SHOWING THE TERMS OF ANY DEALER WARRANTY OR SERVICE CONTRACT IS FURNISHED BY DEALER TO BUYER, THIS VEHICLE IS SOLD "AS IS - NOT EXPRESSLY WARRANTED OR GUARANTEED", AND THE SELLER HEREBY DISCLAIMS ALL WARRANTIES, EITHER EXPRESS OR IMPLIED, INCLUDING ANY IMPLIED WARRANTY OF MERCHANTABILITY OR FITNESS FOR A PARTICULAR PURPOSE.
9. **PURCHASER SHALL NOT BE ENTITLED TO RECOVER FROM DEALER ANY CONSEQUENTIAL DAMAGES, DAMAGES TO PROPERTY, DAMAGES FOR LOSS OF USE, LOSS OF TIME, LOSS OF PROFITS, OR INCOME, OR ANY OTHER INCIDENTAL DAMAGES.**
10. The Purchaser, before or at the time of delivery of the motor vehicle covered by this Order will execute such forms of agreement or documents as may be required by the terms and conditions of payment indicated on the front of this Order.

Purchaser's Initials



HENDERSON

CUSTOMER QUOTE

PRODUCTS, INC.

Page 1

400 W. SAINT EUNICE RD.
FULTON, MO 65251
PHONE: 573-826-2911
FAX: 573-826-2912

To: City of Leavenworth
Attn: Chuck Staples
Quote Date: 6/22/2018
Valid Until: 7/22/2018

Quoted By: Timothy Bruemmer
Quote #: 113875-13
Phone:
Fax:
Email: tbruemmer@hendersonproducts.com

Quoted:

Leavenworth MKE Dump with Plow Hitch and Controls (NO SPrreader Functions)

Henderson Products is pleased to present the following quote. Please contact us if you have any questions.

Installation Workup

Facility: IDC-MO
Delivery Method: Henderson Delivers (1-125 Mi)

Hitch Type: Low Profile or Manual Tilt Type Hitch
Mount Type: Cheek Plate Mount Kit (Select type below)
Mount Kit Model (Req'd): Low Pro/MT Ck Plt Kit (No Wng, 34"w Full Frame)
Front Bumper: Fabricated Channel Bumper (2pc design) (MFG Material)

Dump Body Type: Mark E Tandem Axle
Floor Length: 15ft Floor Length
Hoist Type: Tele Trunnion Hoist, Internal Doghouse
Cylinder Type: Single Acting
Body Material (Sides/ends): Stainless Steel Type Body Material
Tailgate Release Type: IDC supplied Electric over air valve
Cabshield Install: Supl'd by fact, welded to body @ IDC, sales to order w/ unit
Asphalt Lip (FF Only): Supld by Fact, instll @ IDC, Bolt On (Sales order with unit)

Step(s): Supplied and install @ IDC (select from step options below)

Step QTY: 3

Step 1 Type: SS Serrated 18" Step (For Flat Surface)

Step 1 Location: Driver Side Front, outside

Step 2 Type: SS Serrated 18" Step (For Flat Surface)

Step 2 Location: Driver Side Front, outside

Step 3 Type: SS Serrated 18" Step (For Flat Surface)

Step 3 Location: Driver Side Front, inside

Grab Handle(s): (1) Factory supl'd, install @ IDC (Sales to order with unit)

Sideboards: Wood (Un-Painted), supplied/installed by IDC

Tarp Brand: US Tarp (order 86" c/s if using integral shield)

Tarp System: Electric Tarp, Bullet Proof Arms, w/ Wing Deflector

Tarp Material: Black Vinyl (Asphalt rated)

Tarp Length: 15' Body or shorter Length (BV,US)

Chassis Accessories: Yes (SELECT RELATED OPTIONS BELOW)

Mudflaps (Rear): Swinging w/Logo

Mudflap Type (Rear): 36" Swinging, Mild (with LOGO)

Fenders: Front Quarter Fenders, Poly (standard)





HENDERSON

PRODUCTS, INC.

400 W. SAINT EUNICE RD.
FULTON, MO 65251
PHONE: 573-826-2911
FAX: 573-826-2912

CUSTOMER QUOTE

Page 2

Pintle Plate: None (Cover Plate Only, 3LTC, Lic Plt Lt)
Pintle Hook: Not Required
Truck Wash: Complete Truck Wash/Clean/Vac 1
Warranty: Standard 1 Year Warranty

Electrical: Yes (SELECT RELATED OPTIONS BELOW)
Power Distribution Panel: Power Distribution Panel
Misc Electrical Supplies: Req'd Misc Elect Supplies
Plow Lights: Plow Lts, Halogen, Trucklite All Chassis, (PAIR)
Plow Light Brackets: Plow Lt Hood Brckts, SS, INTERNATIONAL
Cabshield Warning Lights: QTY 2, 6" LED Oval Strobes, Amber (order holes w/unit)
Cabshield S/T/T: Not Required
Rear Dump Bolster (S/T/T): LED S/T/T, kit (West) (order holes)
Rear Dump Bolster (Back-up): B/U Lights, LED, Clear, Oval, pair (Order holes with body)
Rear Dump Bolster Strobes: 6" LED Oval Strobes, Amber, 1 PR, (order holes w/unit)
Back up alarm: Backup Alarm, 102db
Backbone & Wire Standoffs: 14' Backbone (For TA)

Hydraulics: Full Hydraulic Package
Hyd Supplier: Force America (Select Pkg Below)
Hyd Supplier (Spec): Front Mount Crank Driven Pump with Hoist and Plow Function
Controls Type: Cable Controls
Cable Qty: 2 Functions
Quick Coupler Upgrade: Standard Quick Couplers

Hydraulics notes:

Mark-E Tandem Axle

Body Length: 15' BODY LENGTH
Side Style: STRAIGHT SIDES
Side Height (From Floor): 44" SIDE HEIGHT
Rear Body Profile: STANDARD STRAIGHT VERTICAL GATE
Rear Corner Posts: REAR BOLSTERS 8" ABOVE SIDES
Board Pockets: 2" WIDE BOARD POCKETS
Hoist Type: TRN MOUNT TELE, INTERNAL DOGHOUSE
Hoist Cylinder/Model: MAILHOT G3-SERIES, SINGLE ACTING, GS140-5-3
Hydraulic Pump: NO FACTORY SUPPLIED HYDRAULIC PUMP
Cylinder Cradle Style: STANDARD HOIST CRADLE
Install Cylinder: SHIP LOOSE - DEALER TO INSTALL
Hydraulic Reservoir: NO RESERVOIR - DEALER TO SUPPLY
Floor Material: 3/16" AR400 FLOOR
Floor to Side Radius: 45 DEGREE FLOOR TO SIDE
Longsill Material: 8" I-BEAM LONGSILLS (STANDARD SKIP WELD)



HENDERSON

CUSTOMER QUOTE

PRODUCTS, INC.

Page 3

400 W. SAINT EUNICE RD.

FULTON, MO 65251

PHONE: 573-826-2911

FAX: 573-826-2912

Sides/Headsheet Material Type: 201 GRADE STAINLESS STEEL SIDES/HEADSHEET
Sides/Headsheet Thickness: 7GA 201SS SIDES/HEAD
Side Bracing Type: (ONE) WELD-ON INTERMEDIATE SIDE BRACE, EA SIDE
Side Brace Material: 10GA 201SS SIDE BRACING
Top Rail Style: FLAT (2" FLAT, THEN SLOPED)
Top Rail Material: 10GA 201SS TOP RAIL
Rub Rail Material: 10GA 201SS RUB RAIL
Contoured Front Corner Posts: NO FRONT CORNER POSTS
Rear Corner Post Material: 7GA 201SS REAR CORNER POSTS
Tailgate Style: STANDARD TAILGATE
Tailgate Sheet Material: 10GA 201SS TAILGATE SHEET
Tailgate Bracing: (ONE) INTERMEDIATE HORIZONTAL TAILGATE BRACE
Tailgate Material: 10GA 201SS TAILGATE BRACING
Tailgate Top Pivot Hardware: 1-1/4" PINS, 1" PLATES, NON-GREASABLE
Tailgate Latch Type: DBL ACTING AIR CYL TG RELEASE, SS BUSHINGS
Tailgate Release Valve: NO TAILGATE RELEASE VALVE
Tailgate Pin Lanyards: NO TAILGATE PIVOT PIN LANYARDS
Tailgate Lift Loop: NO TAILGATE LIFT LOOP OR DRING
Latch Jaws: LOWER TG LATCH JAWS, GREASABLE
Coal Chute: NO COAL CHUTE
Rear Face Light Holes: (3) OBOUND LIGHT HOLES, EA BOLSTER REAR FACE
Rear Side Marker Light Hole: STD 2.5" SIDE MARKER LIGHT HOLES
Rub Rail Marker Light Hole: NO FRONT MARKER LIGHT HOLES
Exterior Light Boxes Installed: NO EXTERIOR LIGHT BOXES
Lighting Package: NO OEM LIGHTING PACKAGE
Body Hinge Construction: STD 8" X 6" X 1/2" REAR HINGE ANGLE
Body Hinge Type: GREASABLE HINGE BLOCKS
Body Hinge Paint: YES, REAR HINGE PAINTED @ FACTORY
Paint Preparation: SS WASH-NATURAL FINISH, PRIME MILD PARTS (201/304SS BODY)
Cabshield Style: STANDARD WELD ON CABSHIELD
Cabshield Material: 10GA W/ 7GA END PLATES (201SS)
Cabshield Size: 22" X 86" CABSHIELD (1/2 CAB)
Cabshield Mounted Light Holes: TWO OVALS, FRONT/SIDE @ 45 DEGREE
Install Cabshield: CABSHIELD SHIPPED LOOSE, DEALER TO INSTALL
Asphalt Lip: NO ASPHALT LIP
Walk Rails: WALK RAIL INSTALLED ON LOWER RUBRAILS
Walk Rail Material: STAINLESS STEEL WALKRAIL MATERIAL
Walk Rail Type: 1/4" X 1-1/2" FLAT BAR (304SS)
Tarp Rails: TARP RAILS ON BOTH SIDES OF BODY
Tarp Rail Material: STAINLESS STEEL TARP RAIL
Tarp Rail Type: 1/4" X 1-1/2" FLAT BAR (304SS)
Side Ladders: (NO) SIDE LADDER
Body Step Options: NO STEP(S)
Grab Handles: NO GRAB HANDLES
Show Options: Show Options
Sideboards: NO SLOPED SIDEBOARDS
Rubber Mounting Pads: NO RUBBER MOUNTING PADS
Vibrator Mounting Pad: NO VIBRATOR MOUNTING PAD
Rear Apron Filler Plate (for TGS Sander): NO REAR APRON FILL PLATE



HENDERSON

PRODUCTS, INC.

400 W. SAINT EUNICE RD.
FULTON, MO 65251
PHONE: 573-826-2911
FAX: 573-826-2912

CUSTOMER QUOTE

Page 4

Install TGS Spreader: NO TGS INSTALL
Heated Body: NO HEATED BODY OPTION
Cradle Mount Toolbox: NO TRIANGULAR CRDL MOUNT TOOLBOX (SLOPED HEAD P2P ONLY)
Toolbox (Body Integral): NO INTEGRAL BODY TOOLBOX
Option 1 Description: Asphalt Lip 152496.201 Stainless Bolt On
Option 2 Description: Water Tight Tailgate
Option 3 Description: Side Board Brace in Middle Top each side
Option 4 Description: AR Tailgate Liner

Snow Plow Hitch

Hitch, Truck Portion: Quick hitch, low profile
Quick Hitch Latch Width: 30.5" center-to-center width
Lift Arm Type: 3 Point Lift reduces pin wear fold down arm for safe storage
Lift Arm Size: Telescoping Arm with 4x4x3/8" outer and 3x3x3/4" inner tube
Lift Lug(s): Standard 1/2" plate with key holes for 1/2" chain
Hydraulic Lift Cylinder: 3" x 2" x 10" Double Acting Nitrided Lift Cylinder, std

Single Package: \$38,525.00
Package(s) : 1
Total: \$38,525.00

Signed: _____ Date: _____

Quote notes:

201 Stainless Steel Sides and Ends Dump Body with AR Floor and Tailgate Liner
Sealing Tailgate Option
Force America Front Crankshaft Driven Pump Cable Hoist and Plow Controls.
Henderson Quick Hitch Plow to match existing plows 30.5" Centers
NO CONTROLS OR PLUMBING FOR SPREADER





08 27 2016



TRUCK GROUP

A REACH COMPANY

2700 NE 38TH STREET • KANSAS CITY, MO 64116 • 816 455-1633 • FAX 816-455-2796

NJPA

City of Leavenworth, KS
Chuck Staples

6/25/18

1- 2019 International Model HV507

Complete with 15' Stainless Steel dump body, central hydraulics to operate a snowplow, Snowplow hitch mount on truck. Water tight tailgate

Sale price each

\$126,556.00

NOTE: All body equipment provided by Henderson Truck Equipment

Respectfully submitted,

Howard Gentry
Transportation Consultant

Summit Truck Group
1-800-279-8500

PO# _____

Accepted by: _____

Date _____

Prepared For:
City of Leavenworth, KS
Chuck Staples
100 N. 5th Street
Leavenworth, KS 66048-
(913)682 - 9201
Reference ID: plow chassis

Presented By:
Summit Truck Group
Howard J Gentry
7700 N.E. 38th Street
Kansas City MO 64161 -
(816)455-1833

Model Profile
2019 HV507 SFA (HV507)

AXLE CONFIG:	6X4
APPLICATION:	Front Plow with spreader
MISSION:	Requested GVWR: 58000. Calc. GVWR: 58000 Calc. Start / Grade Ability: 18.89% / 2.13% @ 55 MPH Calc. Geared Speed: 78.2 MPH
DIMENSION:	Wheelbase: 201.00, CA: 126.00, Axle to Frame: 75.00
ENGINE, DIESEL:	{Cummins L9 350} EPA 2017, 350HP @ 2000 RPM, 1150 lb-ft Torque @ 1400 RPM, 2200 RPM Governed Speed, 350 Peak HP (Max)
TRANSMISSION, AUTOMATIC:	{Allison 3000 RDS} 5th Generation Controls, Close Ratio, 6-Speed with Double Overdrive, with PTO Provision, Less Retarder, Includes Oil Level Sensor, On/Off Highway
CLUTCH:	Omit Item (Clutch & Control)
AXLE, FRONT NON-DRIVING:	{Meritor MFS-18-133A} Wide Track, I-Beam Type, 18,000-lb Capacity
AXLE, REAR, TANDEM:	{Meritor MT-40-14X-4DER} Single Reduction, 40,000-lb Capacity, w/.433"(11mm) Wall Housing Thickness, Driver Controlled Locking Differential in Rear-Rear Axle, R Wheel Ends Gear Ratio: 5.29
CAB:	Conventional
TIRE, FRONT:	(2) 315/80R22.5 Load Range L HSC1 (CONTINENTAL), 484 rev/mile, 68 MPH, All-Position
TIRE, REAR:	(8) 11R22.5 Load Range G HDR2 (CONTINENTAL), 491 rev/mile, 75 MPH, Drive
SUSPENSION, REAR, TANDEM:	{Hendrickson HMX-400-54} Walking Beam Type 54" Axle Spacing; 40,000-lb Capacity, with Rubber End Bushings, Transverse Torque Rods, Less Shock Absorbers
PAINT:	Cab schematic 100WK Location 1: 9219, Winter White (Std) Chassis schematic N/A

Description

Base Chassis, Model HV507 SFA with 201.00 Wheelbase, 126.00 CA, and 75.00 Axle to Frame.

TOW HOOK, FRONT (2) Frame Mounted

AXLE CONFIGURATION {Navistar} 6x4

FRAME RAILS Heat Treated Alloy Steel (120,000 PSI Yield); 10.866" x 3.622" x 0.433" (276.0mm x 92.0mm x 11.1mm); 456.0" (11582mm) Maximum OAL

BUMPER, FRONT Steel, Swept Back

FRAME EXTENSION, FRONT Integral; 20" In Front of Grille

WHEELBASE RANGE 177" (450cm) Through and Including 226" (575cm)

AXLE, FRONT NON-DRIVING {Meritor MFS-18-133A} Wide Track, I-Beam Type, 18,000-lb Capacity

SUSPENSION, FRONT, SPRING Parabolic, Taper Leaf; 18,000-lb Capacity; with Shock Absorbers

BRAKE SYSTEM, AIR Dual System for Straight Truck Applications

BRAKES, FRONT, AIR CAM 16.5" x 6", Includes 24 SqIn Long Stroke Brake Chambers

DRAIN VALVE {Berg} with Pull Chain, for Air Tank

AIR BRAKE ABS {Bendix AntiLock Brake System} Full Vehicle Wheel Control System (4-Channel)

AIR DRYER {Wabco System Saver 1200} with Heater

BRAKE CHAMBERS, REAR AXLE {Bendix EverSure} 30/30 Spring Brake

BRAKE CHAMBERS, FRONT AXLE {Bendix} 24 SqIn

SLACK ADJUSTERS, FRONT {Haldex} Automatic

SLACK ADJUSTERS, REAR {Haldex} Automatic

BRAKES, REAR, AIR CAM S-Cam; 16.5" x 7.0"; Includes 30/30 Sq.In. Long Stroke Brake Chamber and Spring Actuated Parking Brake

AIR COMPRESSOR {Cummins} 18.7 CFM Capacity

AIR DRYER LOCATION Mounted Inside Left Rail, Back of Cab

AIR TANK LOCATION (2) Mounted Under Battery Box, Outside Right Rail, Back of Cab, Perpendicular to Rail

DUST SHIELDS, FRONT BRAKE for Air Brakes

DUST SHIELDS, REAR BRAKE for Air Brakes

BRAKE CHAMBERS, SPRING on Rear/Rear Axle Located Inside Rear Tire Envelope (Meets Asphalt Spreader/Paver Clearance Requirements)

STEERING COLUMN Tilting

STEERING WHEEL 4-Spoke; 18" Dia., Black

STEERING GEAR (2) {Sheppard M100/M80} Dual Power

AFTERTREATMENT COVER Polished Aluminum

EXHAUST SYSTEM Single Horizontal Aftertreatment Device, Frame Mounted Right Side Under Cab; for Single Vertical Tail Pipe, Frame Mounted Right Side Back of Cab

TAIL PIPE (1) Turnback Type, Non-Bright, for Single Exhaust

EXHAUST HEIGHT 10'

MUFFLER/TAIL PIPE GUARD (1) Non-Bright Aluminum

Description

ELECTRICAL SYSTEM 12-Volt, Standard Equipment

CIGAR LIGHTER Includes Ash Cup

SNOW SHIELD (2) Chrome; for Dual Air Horns

ALTERNATOR {Leece-Neville AV160P2013} Brush Type; 12 Volt 160 Amp. Capacity, Pad Mount, with Remote Sense

BODY BUILDER WIRING Back of Standard or Sleeper Cab at Left Frame or Under Extended or Crew Cab at Left Frame; Includes Sealed Connectors for Tail/Amber Turn/Marker/ Backup/Accessory Power/Ground and Sealed Connector for Stop/Turn

HORN, AIR (2) Single Tone, Chrome, Roof Mounted, with Lanyard Pull Cord

BATTERY SYSTEM {Fleetrite} Maintenance-Free, (3) 12-Volt 1980CCA Total

RADIO AM/FM/WB/Clock/3.5MM Auxiliary Input

SPEAKERS (2) 5.25" Dual Cone Mounted in Both B-Pillars

AUXILIARY HARNESS 3.0' for Auxiliary Front Head Lights and Turn Signals for Front Plow Applications

HORN, ELECTRIC Disc Style

BATTERY BOX Steel with Plastic Cover, 18" Wide, 2, 3, or 4 Battery Capacity, Mounted Right Side Back of Cab

WINDSHIELD WIPER SPD CONTROL Force Wipers to Slowest Intermittent Speed When Park Brake Set and Wipers Left on for a Predetermined Time

CLEARANCE/MARKER LIGHTS (5) {Truck Lite} Amber LED Lights, Flush Mounted on Cab or Sunshade

TEST EXTERIOR LIGHTS Pre-Trip Inspection will Cycle all Exterior Lamps Except Back-up Lights

HEADLIGHTS ON W/WIPERS Headlights Will Automatically Turn on if Windshield Wipers are turned on

STARTING MOTOR {Delco Remy 39MT} 12 Volt; Gear Reduced, with Thermal Over-Crank Protection

INDICATOR, LOW COOLANT LEVEL with Audible Alarm

ALARM, PARKING BRAKE Electric Horn Sounds in Repetitive Manner When Vehicle Park Brake is "NOT" Set, with Ignition "OFF" and any Door Opened

CIRCUIT BREAKERS Manual-Reset (Main Panel) SAE Type III with Trip Indicators, Replaces All Fuses

TURN SIGNALS, FRONT Includes LED Side Turn Lights Mounted on Fender

BATTERY DISCONNECT SWITCH 300 Amp; Cab Mounted, Disconnects Charging Circuits; Locks with Padlock

LOGOS EXTERIOR Model Badges

LOGOS EXTERIOR, ENGINE Badges

INSULATION, UNDER HOOD for Sound Abatement

GRILLE Stationary, Chrome

INSULATION, SPLASH PANELS for Sound Abatement

BUG SCREEN Mounted Behind Grille

FRONT END Tilting, Fiberglass, with Three Piece Construction; for WorkStar/HV

PAINT SCHEMATIC, PT-1 Single Color, Design 100

PAINT TYPE Base Coat/Clear Coat, 1-2 Tone

KEYS - ALL ALIKE Fleet - Includes Ignition and Cab Door Keys

PROMOTIONAL PACKAGE Government Silver Package

Description

KEYS - ALL ALIKE, ID I-1003 Compatible with Z-001

CLUTCH Omit Item (Clutch & Control)

ANTI-FREEZE Red, Extended Life Coolant; To -40 Degrees F/ -40 Degrees C, Freeze Protection

BLOCK HEATER, ENGINE 120V/1000W, for Cummins ISB/B6.7/ISL/L9 Engines

PTO EFFECTS, ENGINE FRONT Less PTO Unit, Includes Adapter Plate on Engine Front Mounted

ENGINE, DIESEL {Cummins L9 350} EPA 2017, 350HP @ 2000 RPM, 1150 lb-ft Torque @ 1400 RPM, 2200 RPM Governed Speed, 350 Peak HP (Max)

FAN DRIVE {Horton Drivemaster} Direct Drive Type, Two Speed with Residual Torque Device for Disengaged Fan Speed

RADIATOR Cross Flow, Series System; 1228 SqIn Aluminum Radiator Core with Internal Water to Oil Transmission Cooler and 1167 In Charge Air Cooler

AIR CLEANER Single Element, with Integral Snow Valve and In-Cab Control

FEDERAL EMISSIONS {Cummins L9} EPA, OBD and GHG Certified for Calendar Year 2018

THROTTLE, HAND CONTROL Engine Speed Control; Electronic, Stationary, Variable Speed; Mounted on Steering Wheel

EMISSION COMPLIANCE Federal, Does Not Comply with California Clean Air Idle Regulations

ENGINE CONTROL, REMOTE MOUNTED Provision for; Includes Wiring for Body Builder Installation of PTO Controls; with Ignition Switch Control for Cummins ISB/B6.7 or ISL/L9 Engines

TRANSMISSION, AUTOMATIC {Allison 3000 RDS} 5th Generation Controls, Close Ratio, 6-Speed with Double Overdrive, with PTO Provision, Less Retarder, Includes Oil Level Sensor, On/Off Highway

TRANSMISSION SHIFT CONTROL for Column Mounted Stalk Shifter

TRANSMISSION OIL Synthetic; 29 thru 42 Pints

ALLISON SPARE INPUT/OUTPUT for Rugged Duty Series (RDS); General Purpose Trucks, Construction

TRANSMISSION TCM LOCATION Located Inside Cab

SHIFT CONTROL PARAMETERS Allison 3000 or 4000 Series Transmissions, 5th Generation Controls, Performance Programming

PTO LOCATION Left Side of Transmission

AXLE, REAR, TANDEM {Meritor MT-40-14X-4DER} Single Reduction, 40,000-lb Capacity, w/.433"(11mm) Wall Housing Thickness, Driver Controlled Locking Differential in Rear-Rear Axle, R Wheel Ends . Gear Ratio: 5.29

SUSPENSION, REAR, TANDEM {Hendrickson HMX-400-54} Walking Beam Type 54" Axle Spacing; 40,000-lb Capacity, with Rubber End Bushings, Transverse Torque Rods, Less Shock Absorbers

SUSPENSION/REAR-AXLE IDENTITY for Meritor Tandem Rear Axles with Bar-Pin Beam Attachment Type Suspensions

DEF TANK 9.5 U.S. Gal. 35.9L Capacity, Frame Mounted Outside Left Rail, Under Cab

LOCATION FUEL/WATER SEPARATOR Mounted Outside Left Rail, 41" Back of Cab

FUEL/WATER SEPARATOR {Racor 400 Series,} 12 VDC Electric Heater, Includes Pre-Heater, with Primer Pump, Includes Water-in-Fuel Sensor

FUEL TANK Top Draw, Non-Polished Aluminum, 26" Dia, 80 US Gal (303L), Mounted Left Side, Under Cab

CAB Conventional

HEATER SHUT-OFF VALVES (1) Ball Valve Type, Supply Line

AIR CONDITIONER with Integral Heater & Defroster

Description

GAUGE CLUSTER Base Level; English with English Speedometer and Tachometer, for Air Brake Chassis, Includes Engine Coolant Temperature, Primary and Secondary Air Pressure, Fuel and DEF Gauges, Oil Pressure Gauge, Includes 3 Inch Monochromatic Text Display

GAUGE, OIL TEMP, AUTO TRANS for Allison Transmission

IP CLUSTER DISPLAY On Board Diagnostics Display of Fault Codes in Gauge Cluster

SEAT, DRIVER {National 2000} Air Suspension, High Back with Integral Headrest, Mordura Cloth, Isolated, with 2 Position Front Cushion Adjustment, -3 to +14 Degree Seat Back Adjustment, Single Chamber Air Lumbar Support

SEAT, PASSENGER {National} Non Suspension, High Back with Integral Headrest, Mordura Cloth, with Fixed Back

GRAB HANDLE Chrome; Towel Bar Type with Anti-Slip Rubber Inserts; for Cab Entry Mounted Left Side Only at "B" Pillar

MIRROR, CONVEX, HOOD MOUNTED (2) {Lang Mekra} Heated, Left and Right Sides 7.44" Sq

MIRRORS (2) Power Adjust, Thermostatically Controlled Heated Heads, Black Heads, Brackets and Arms, 7.55" x 14.1" Flat Glass, 7.48" x 6.77" Convex Glass Both Sides

CAB INTERIOR TRIM Classic, for Day Cab

WINDSHIELD Heated, Single Piece

ARM REST, RIGHT, DRIVER SEAT

WINDOW, POWER (2) and Power Door Locks, Left and Right Doors, Includes Express Down Feature

CAB REAR SUSPENSION Air Bag Type

INSTRUMENT PANEL Wing Panel

ACCESS, CAB Steel, Driver & Passenger Sides, Two Steps Per Door, for use with Regular and Extended Cabs

WHEELS, FRONT {Accuride 29300} DISC; 22.5x9.00 Rims, Powder Coat Steel, 5-Hand Hole, 10-Stud, 285.75mm BC, Hub-Piloted, Flanged Nut, with Steel Hubs

WHEELS, REAR {Accuride 29169} DUAL DISC; 22.5x8.25 Rims, Powder Coat Steel, 5-Hand Hole, 10-Stud, 285.75mm BC, Hub-Piloted, Flanged Nut, with .472" Thick Increased Capacity Disc and Steel Hubs

BDY INTG, PTO ACCOMMODATION for (3) Latched Rocker Switches, (1) PTO Switch, (2) Generic Switches to Control (3) 30 amp relays, with Programmable Interlocks, for Body Builder Hook up in the Engine Compartment Left Side, Recommended for Automatic Transmissions

(8) TIRE, REAR 11R22.5 Load Range G HDR2 (CONTINENTAL), 491 rev/mile, 75 MPH, Drive

(2) TIRE, FRONT 315/80R22.5 Load Range L HSC1 (CONTINENTAL), 484 rev/mile, 68 MPH, All-Position

Services Section:

WARRANTY Standard for HV507, HV50B, HV607 Models, Effective with Vehicles Built July 1, 2017 or Later, CTS-2025A

15' dump with central hydraulics for plow and spreader from Henderson Truck Equipment. No plow or spreader included

drop ship It

Set engine parameters 75MPH on pedal, 74MPH on Cruise Summit Service
Program 3 pack switches to wide open setting



HENDERSON

PRODUCTS, INC.

400 W. SAINT EUNICE RD.
FULTON, MO 65251
PHONE: 573-826-2911
FAX: 573-826-2912

CUSTOMER QUOTE

Page 2

Pintle Plate: None (Cover Plate Only, 3LTC, Lic Plt Lt)
Pintle Hook: Not Required
Truck Wash: Complete Truck Wash/Clean/Vac 1
Warranty: Standard 1 Year Warranty

Electrical: Yes (SELECT RELATED OPTIONS BELOW)
Power Distribution Panel: Power Distribution Panel
Misc Electrical Supplies: Req'd Misc Elect Supplies
Plow Lights: Plow Lts, Halogen, Trucklite All Chassis, (PAIR)
Plow Light Brackets: Plow Lt Hood Brckts, SS, INTERNATIONAL
Cabshield Warning Lights: QTY 2, 6" LED Oval Strobes, Amber (order holes w/unit)
Cabshield S/T/T: Not Required
Rear Dump Bolster (S/T/T): LED S/T/T, kit (West) (order holes)
Rear Dump Bolster (Back-up): B/U Lights, LED, Clear, Oval, pair (Order holes with body)
Rear Dump Bolster Strobes: 6" LED Oval Strobes, Amber, 1 PR, (order holes w/unit)
Back up alarm: Backup Alarm, 102db
Backbone & Wire Standoffs: 14' Backbone (For TA)

Hydraulics: Full Hydraulic Package
Hyd Supplier: Force America (Select Pkg Below)
Hyd Supplier (Spec): Front Mount Crank Driven Pump with Hoist and Plow Function
Controls Type: Cable Controls
Cable Qty: 2 Functions
Quick Coupler Upgrade: Standard Quick Couplers

Hydraulics notes:

Mark-E Tandem Axle

Body Length: 15' BODY LENGTH
Side Style: STRAIGHT SIDES
Side Height (From Floor): 44" SIDE HEIGHT
Rear Body Profile: STANDARD STRAIGHT VERTICAL GATE
Rear Corner Posts: REAR BOLSTERS 8" ABOVE SIDES
Board Pockets: 2" WIDE BOARD POCKETS
Hoist Type: TRN MOUNT TELE, INTERNAL DOGHOUSE
Hoist Cylinder/Model: MAILHOT G3-SERIES, SINGLE ACTING, GS140-5-3
Hydraulic Pump: NO FACTORY SUPPLIED HYDRAULIC PUMP
Cylinder Cradle Style: STANDARD HOIST CRADLE
Install Cylinder: SHIP LOOSE - DEALER TO INSTALL
Hydraulic Reservoir: NO RESERVOIR - DEALER TO SUPPLY
Floor Material: 3/16" AR400 FLOOR
Floor to Side Radius: 45 DEGREE FLOOR TO SIDE
Longsill Material: 8" I-BEAM LONGSILLS (STANDARD SKIP WELD)





HENDERSON

CUSTOMER QUOTE

PRODUCTS, INC.

Page 1

400 W. SAINT EUNICE RD.
FULTON, MO 65251
PHONE: 573-826-2911
FAX: 573-826-2912

To: City of Leavenworth
Attn: Chuck Staples
Quote Date: 6/22/2018
Valid Until: 7/22/2018

Quoted By: Timothy Bruemmer
Quote #: 113875-13
Phone:
Fax:
Email: tbruemmer@hendersonproducts.com

Quoted:

Leavenworth MKE Dump with Plow Hitch and Controls (NO SPrreader Functions)

Henderson Products is pleased to present the following quote. Please contact us if you have any questions.

Installation Workup

Facility: IDC-MO
Delivery Method: Henderson Delivers (1-125 Mi)

Hitch Type: Low Profile or Manual Tilt Type Hitch
Mount Type: Cheek Plate Mount Kit (Select type below)
Mount Kit Model (Req'd): Low Pro/MT Ck Plt Kit (No Wng, 34"w Full Frame)
Front Bumper: Fabricated Channel Bumper (2pc design) (MFG Material)

Dump Body Type: Mark E Tandem Axle
Floor Length: 15ft Floor Length
Hoist Type: Tele Trunnion Hoist, Internal Doghouse
Cylinder Type: Single Acting
Body Material (Sides/ends): Stainless Steel Type Body Material
Tailgate Release Type: IDC supplied Electric over air valve
Cabshield Install: Supl'd by fact, welded to body @ IDC, sales to order w/ unit
Asphalt Lip (FF Only): Supld by Fact, instll @ IDC, Bolt On (Sales order with unit)

Step(s): Supplied and install @ IDC (select from step options below)
Step QTY: 3

Step 1 Type: SS Serrated 18" Step (For Flat Surface)
Step 1 Location: Driver Side Front, outside
Step 2 Type: SS Serrated 18" Step (For Flat Surface)
Step 2 Location: Driver Side Front, outside
Step 3 Type: SS Serrated 18" Step (For Flat Surface)
Step 3 Location: Driver Side Front, inside

Grab Handle(s): (1) Factory supl'd, install @ IDC (Sales to order with unit)
Sideboards: Wood (Un-Painted), supplied/installed by IDC
Tarp Brand: US Tarp (order 86" c/s if using integral shield)
Tarp System: Electric Tarp, Bullet Proof Arms, w/ Wing Deflector
Tarp Material: Black Vinyl (Asphalt rated)
Tarp Length: 15' Body or shorter Length (BV,US)

Chassis Accessories: Yes (SELECT RELATED OPTIONS BELOW)
Mudflaps (Rear): Swinging w/Logo
Mudflap Type (Rear): 36" Swinging, Mild (with LOGO)
Fenders: Front Quarter Fenders, Poly (standard)





HENDERSON

CUSTOMER QUOTE

PRODUCTS, INC.

Page 4

400 W. SAINT EUNICE RD.
FULTON, MO 65251
PHONE: 573-826-2911
FAX: 573-826-2912

Install TGS Spreader: NO TGS INSTALL
Heated Body: NO HEATED BODY OPTION
Cradle Mount Toolbox: NO TRIANGULAR CRDL MOUNT TOOLBOX (SLOPED HEAD P2P ONLY)
Toolbox (Body Integral): NO INTEGRAL BODY TOOLBOX
Option 1 Description: Asphalt Lip 152496.201 Stainless Bolt On
Option 2 Description: Water Tight Tailgate
Option 3 Description: Side Board Brace in Middle Top each side
Option 4 Description: AR Tailgate Liner

Snow Plow Hitch

Hitch, Truck Portion: Quick hitch, low profile
Quick Hitch Latch Width: 30.5" center-to-center width
Lift Arm Type: 3 Point Lift reduces pin wear fold down arm for safe storage
Lift Arm Size: Telescoping Arm with 4x4x3/8" outer and 3x3x3/4" inner tube
Lift Lug(s): Standard 1/2" plate with key holes for 1/2" chain
Hydraulic Lift Cylinder: 3" x 2" x 10" Double Acting Nitrided Lift Cylinder, std

Single Package: \$38,525.00
Package(s) : 1
Total: \$38,525.00

Signed: _____ Date: _____

Quote notes:

201 Stainless Steel Sides and Ends Dump Body with AR Floor and Tailgate Liner
Sealing Tailgate Option
Force America Front Crankshaft Driven Pump Cable Hoist and Plow Controls.
Henderson Quick Hitch Plow to match existing plows 30.5" Centers
NO CONTROLS OR PLUMBING FOR SPREADER





HENDERSON

CUSTOMER QUOTE

PRODUCTS, INC.

Page 3

400 W. SAINT EUNICE RD.
FULTON, MO 65251
PHONE: 573-826-2911
FAX: 573-826-2912

Sides/Headsheet Material Type: 201 GRADE STAINLESS STEEL SIDES/HEADSHEET
Sides/Headsheet Thickness: 7GA 201SS SIDES/HEAD
Side Bracing Type: (ONE) WELD-ON INTERMEDIATE SIDE BRACE, EA SIDE
Side Brace Material: 10GA 201SS SIDE BRACING
Top Rail Style: FLAT (2" FLAT, THEN SLOPED)
Top Rail Material: 10GA 201SS TOP RAIL
Rub Rail Material: 10GA 201SS RUB RAIL
Contoured Front Corner Posts: NO FRONT CORNER POSTS
Rear Corner Post Material: 7GA 201SS REAR CORNER POSTS
Tailgate Style: STANDARD TAILGATE
Tailgate Sheet Material: 10GA 201SS TAILGATE SHEET
Tailgate Bracing: (ONE) INTERMEDIATE HORIZONTAL TAILGATE BRACE
Tailgate Material: 10GA 201SS TAILGATE BRACING
Tailgate Top Pivot Hardware: 1-1/4" PINS, 1" PLATES, NON-GREASABLE
Tailgate Latch Type: DBL ACTING AIR CYL TG RELEASE, SS BUSHINGS
Tailgate Release Valve: NO TAILGATE RELEASE VALVE
Tailgate Pin Lanyards: NO TAILGATE PIVOT PIN LANYARDS
Tailgate Lift Loop: NO TAILGATE LIFT LOOP OR DRING
Latch Jaws: LOWER TG LATCH JAWS, GREASABLE
Coal Chute: NO COAL CHUTE
Rear Face Light Holes: (3) OBOURND LIGHT HOLES, EA BOLSTER REAR FACE
Rear Side Marker Light Hole: STD 2.5" SIDE MARKER LIGHT HOLES
Rub Rail Marker Light Hole: NO FRONT MARKER LIGHT HOLES
Exterior Light Boxes Installed: NO EXTERIOR LIGHT BOXES
Lighting Package: NO OEM LIGHTING PACKAGE
Body Hinge Construction: STD 8" X 6" X 1/2" REAR HINGE ANGLE
Body Hinge Type: GREASABLE HINGE BLOCKS
Body Hinge Paint: YES, REAR HINGE PAINTED @ FACTORY
Paint Preparation: SS WASH-NATURAL FINISH, PRIME MILD PARTS (201/304SS BODY)
Cabshield Style: STANDARD WELD ON CABSHIELD
Cabshield Material: 10GA W/ 7GA END PLATES (201SS)
Cabshield Size: 22" X 86" CABSHIELD (1/2 CAB)
Cabshield Mounted Light Holes: TWO OVALS, FRONT/SIDE @ 45 DEGREE
Install Cabshield: CABSHIELD SHIPPED LOOSE, DEALER TO INSTALL
Asphalt Lip: NO ASPHALT LIP
Walk Rails: WALK RAIL INSTALLED ON LOWER RUBRAILS
Walk Rail Material: STAINLESS STEEL WALKRAIL MATERIAL
Walk Rail Type: 1/4" X 1-1/2" FLAT BAR (304SS)
Tarp Rails: TARP RAILS ON BOTH SIDES OF BODY
Tarp Rail Material: STAINLESS STEEL TARP RAIL
Tarp Rail Type: 1/4" X 1-1/2" FLAT BAR (304SS)
Side Ladders: (NO) SIDE LADDER
Body Step Options: NO STEP(S)
Grab Handles: NO GRAB HANDLES
Show Options: Show Options
Sideboards: NO SLOPED SIDEBOARDS
Rubber Mounting Pads: NO RUBBER MOUNTING PADS
Vibrator Mounting Pad: NO VIBRATOR MOUNTING PAD
Rear Apron Filler Plate (for TGS Sander): NO REAR APRON FILL PLATE



POLICY REPORT
Consider Contract for Website Redesign
August 14, 2018

Prepared By:



Taylour Tedder
Assistant City Manager

Reviewed By:



Paul Kramer
City Manager

BACKGROUND:

The City's website was identified as a priority to replace during the 2018 budget process as our current website has aged to the point it is lacking functionality and ease of access for residents. A request for qualifications was released and published in the Leavenworth Times on May 23, 2018, and four website vendors submitted successful proposals. Staff hosted the four potential website vendors (Civic Plus, Civic Live, Vision, and Municode) for on-site interviews and demonstrations over a two week period. References were contacted from across the country who implemented sites with the various companies, and their feedback was extremely valuable. The references were able to touch on how the website solutions integrated with their staff members, support, design, functionality, and much more.

A staff committee was formed to sit in on the interviews of the website firms, made up of seven different departments within the city, and additionally scored each firm.

The website proposals were evaluated on the following criteria:

- Front End Edit
- Forms with Payments
- Email subscriptions for news alerts
- Reputation
- Predesign evaluation
- Attractiveness
- Navigation
- Ease for staff to edit
- Administrative levels
- Key staff may edit major features
- Calendar
- Custom/Easy URL
- Analytics
- Security
- Responsive Design/Mobile Friendly
- Document Search on back end
- Re-evaluation of design
- Integrates with Google Maps/other map locator
- Button so constituents can share on social media
- Photo gallery
- Optimizes photos for web
- Will migrate all of current content
- Will provide on-site training
- Support staff
- Searchable documents (searches within PDFs)
- Administrative tracking of edits
- 24/7 emergency support
- "Go Live" timeframe
- Integration of City Code
- Ability to add code from outside widgets/apps

The committee provided consensus to move forward with a Municode website, who has also provided municipal code services for over 40 years to the City. Municode creates stunning, useful, and engaging custom municipal websites. Of the several cities contacted with Municode sites, we received extremely positive feedback from them, and they each have great model websites including: City of Naples, FL, City of Corvallis, OR, City of Brookhaven, GA, City of Los Altos, CA, and City of Wilsonville, OR. The committee's decision was due to the integration of city code into the website search, stunning design, and overall positive reference feedback. The committee ranked the proposals as follows: 1. Municode, 2. CivicPlus, 3. Vision, 4. CivicLive. The design process will be extremely custom and in-depth, with lots of opportunity for comment of various stakeholders, with the website solution.

ACTION:

Approve the services agreement for website design and replacement with Municipal Code Corporation in the amount of \$36,000 for the first year of implementation and training.

ATTACHMENTS:

1. May 23, 2018 RFQ for Website Design and Replacement
2. Municode RFP Response with Pricing
3. Services Agreement

Request for Qualifications and Pricing Proposal

City Website Design and Replacement



Contents

About the City of Leavenworth.....	3
Project Scope	3
Description of Design & Development Services Required.....	3
Content Management System Requirements	4
Design and Development Process	4
Data Migration.....	4
Training and Mentoring of City Staff	4
Phased Project Engagements	5
RFQ Timeline.....	5
RFQ Application Deadline and Instructions	5
Evaluation of Proposals	7
Appendix A - Contract Submittal Addendums.....	8
Appendix B - Web Project Technical Requirements	11

About the City of Leavenworth

Leavenworth is considered an outer-ring suburb of Kansas City, Missouri and is a full-service community to over 36,000 residents. Leavenworth is home to the U.S. Federal Penitentiary at Leavenworth and the Dwight D. Eisenhower Veterans Affairs Medical Center, part of the U.S. Department of Veterans Affairs Eastern Kansas Health Care System. Major employers include Cereal Ingredients, Hallmark Cards, Corrections Corporation of America, as well as the Armed Forces Insurance Center.

Leavenworth is also home to Fort Leavenworth (home of the Combined Arms Center), which houses some of the Army's best and brightest leadership for the United States Military. The base is home to nearly 4,000 residents with an additional 2,000 people traveling on post daily for employment opportunities. Fort Leavenworth provides a dynamic impact on our community and increases the discretionary spending in the community other areas may not have.

The City and its partners, continuously work to diversify the area's economy in an organized, concerted effort to promote commercial, industrial and retail development.

Project Scope

The City of Leavenworth, Kansas is seeking the services of an experienced website design firm to update, redesign, develop and implement a new "look and feel" and Content Management System for the City's websites by utilizing existing information on its current websites list below, as well as new information, products and features as identified in this RFQ. The system should be easy to use allow City staff to add/edit/delete content when necessary. The City has assembled a Web team that will evaluate vendor experience and qualifications as well as make the final RFQ recommendation. Registered City of Leavenworth domain sites include:

www.lvks.org

www.visitleavenworthks.org

Funding has been approved in the City's 2018 budget.

Description of Design & Development Services Required

The City is requesting information from vendors specializing in web design services and Content Management Systems (CMS) able to meet the requirements identified in [Appendix B](#) in this document. The preferred vendor will have knowledge of website management with an emphasis on local government. Highlights of [Appendix B](#) include but are not limited to:

- Website Designs or "look and feel"
- Mobile First - "Responsive Design"
- CMS software
- Implementation of an electronic workflow for all proposed website changes for approval and promotion
- Flexibility in page layout and navigation
- User experience and Section 508/ADA compliance
- Strong web site search design

All design and development will be contracted as work for hire.

Content Management System Requirements

The City of Leavenworth is looking for a website content management system that will be adaptable to current and changing technology and enable content subject matter experts to efficiently publish and manage content on the City website(s). CMS product requirements are listed in [Appendix B](#). Highlights of [Appendix B](#) include but are not limited to:

- WYSIWYG editor / front end
- Spell checker
- Ability to limit features of WYSIWYG editor to maintain common look and feel throughout the website
- Active link verification
- Ability to preview pages prior to publishing

The selected vendor will be expected to provide training and support on the CMS system.

Design and Development Process

The vendor must be an expert in mobile first development and design, specifically geared toward local government websites. This includes programming and integrating with existing applications as well as migrating any current webpages. The RFQ must contain a CMS system that is manageable and scalable. The proposed website design must offer integration with the City's web applications.

Throughout the development process, the vendor will work with the City's Development Web team and, when applicable, user community leaders who will perform beta testing in order to provide feedback on the use of the system.

Successful outcomes would include collaborative design "look and feel", implementation and migration plan, staff training and mentoring. The vendor will work closely with Web team to identify best practices, enhancements and current issues that need to be addressed within the new CMS system.

Data Migration

The vendor must assist the city in the planning and the migration of current webpages and content. Identify solutions for keeping content within our two CMS systems in sync. Vendor must also assist in the organization of current pages to fit within a new, device agnostic design.

Training and Mentoring of City Staff

The vendor will provide all documentation for the processes, procedures and code that will be used to train and mentor the web team. The vendor may be required to provide detailed training materials which should include a written manual with screen shots in PDF format to facilitate instructor led onsite training. The proposal shall include on-site technical and user training. Vendor must have a proven track record of providing staff training and guidance on the utilization of the CMS and best practices in content promotion.

Phased Project Engagements

The City recognizes that this endeavor will encompass several phased engagements. Each engagement will be identified with Scope of Work (SOW) documents. The vendor will be expected to provide a project plan on order of site migration and implementation.

Each engagement or SOW should include the following:

- Project management – Provide a team and methodology to facilitate and lead these engagements and meetings necessary to achieve the desired objectives
- Coordinate multiple meetings with user community leaders and Web team to understand business needs in support of engagement goals
- Coordinate with Web team to ensure compliance with privacy, security and ADA guidelines.
- Support the Web team to develop a work plan outlining key deliverables
- Oversee data and document integration
- Collaborate with Web team to devise a content promotion process and implement a change strategy
- Facilitate the creation, documentation and implementation of a performance monitoring process
- Create and document design requirements
- System backup and recovery

RFQ Timeline

Sequence	Milestone	Target Completion Date
1	RFQ Release	05/23/2018
2	RFQ Submission Deadline	06/22/18 1:30 PM
3	Complete Vendor Evaluations & Presentations	07/13/18 10:00 AM
4	Complete Vendor Selection & Negotiations	08/03/18
5	Presentation to Commission	08/07/18
6	Begin First Engagement	TBD

RFQ Application Deadline and Instructions

Interested contractors/vendors must submit their documents to the City of Leavenworth no later than 1:30 pm on Friday, June 29, 2018. The City will complete a review of all submitted RFQ's by Friday July 13, 2018. Vendors that meet the City's criteria will be contacted to schedule presentation and demonstrations.

The vendor's response to the RFP shall be submitted in the following format and order. Aside from pricing, submissions should be in an electronic format. Failure to conform to this format may be cause for rejection of the proposal.

1. **Cover Sheet**
2. **Table of Contents**
3. **Executive Summary**
4. **Vendor Profile** – This section is to provide information about the vendor and the CMS offered. Company Profile - Number of years in business, Office location(s). If the firm submitting the RFP and the product software provider are not the same company, separate information shall be provided for the vendor submitting the proposal and the software product provider.
5. **Project Staff Background** – This section is to describe the proposed project staff (including sub-contractors) that will be assigned and dedicated to the project. Technical and design support staff, skills and structure.
6. **Project Management** – As required, provide a team and methodology to facilitate and lead these engagements and meetings necessary to achieve the desired objectives.
7. **Experience and References** - This section is to describe Vendor's past projects that are similar to this project in terms of size and scope and utilize the proposed CMS. At least three CMS references in municipal government, including name, title, organization, email and phone number.
 - a. Facilitating references should include reference citing successful requirements gathering and community engagement facilitation.
 - b. Three municipal government references that have replaced their CMS system.
8. **Implementation Plan** – This section is to include an implementation plan addressing the fully-mapped conversion of existing data and images that are archived in the City's current CMS, installation and testing of the new CMS. A general project plan with key dates and milestones should be included to reflect the amount of time it would take to begin and complete the project.
9. **Education and Training** – In this section, the vendor is to provide a proposed plan for education and training including the anticipated number of hours and the location where the training is to take place. It should also include expected outcomes to provide city staff training and guidance on the utilization of the CMS and best practices in content promotion.
10. **Contract Terms** – This section includes information on various contract terms. A copy of the Vendor's most recent contract documents should be attached. The contract submittal should provide a copy of the contract for review by the City. The vendor would need to comply with the addendums found in the Appendix. Should we enter into a contract with a potential vendor, said contract must contain acceptance of the following addendums documented in Appendix A.
11. **Content Management System (CMS) Technical (Appendix B Section A):** Responders are to submit a written narrative or samples corresponding to each of the numbered items identified in Appendix B – Web Project Technical Requirements Section A.
12. **Content Management System (CMS) - Design Components and Tools (Appendix B Section B):** Responders are to submit a written narrative or samples corresponding to each of the numbered items identified in Appendix B – Design Components and Tools Section B.
13. **Web (Appendix B Section C):** Responders are to submit a written narrative or samples corresponding to each of the numbered items identified in Appendix B – Web Section C.

-
14. **Exceptions and Variances** - In this section the vendor is to list any variances from the specifications and requirements of the RFP.
 15. **Pricing** – Detailed cost information for the proposed CMS including an itemized list of “one-time”, “annual”, “optional one-time” and “optional annual” costs shall be provided in a separate envelope clearly marked with the vendor’s name and the word “PRICING”. A five (5) year cost summary and information regarding payments to vendor (payment schedule) should also be included. The cost submittal should provide hourly pricing for the above solution(s). This submittal will contain a professional fee schedule for personnel providing services. Provide additional cost identified (Travel and per diem) for consultant resources and professional services to include design, implementation, migration and training.
 - a. Migration Costs
 - b. CMS - Cost - total cost of CMS System
 - c. Consulting Cost
 - d. Content Conversion Cost
 - e. Hosting Cost
 - f. Cost Breakdown (Consulting, Design, CMS, Content Migration)
 - g. Ongoing maintenance and support cost

Unless specified in the submittals, the City will assume that the professional fee schedule will include any cost associated with complying with the City’s insurance requirements as specified in Appendix A of this RFQ. The City will also assume that any work product developed as a result of contracting with the City will become property of the City.

Sealed proposals can be mailed to:

Web Redesign– RFQ
City of Leavenworth
Attn: Stephanie Alexander, Accountant
100 N. 5th St.
Leavenworth, KS 66048

All questions regarding this RFQ may be submitted to ttedder@firstcity.org by Thursday, June 21, 2018. Answers to all questions will be posted on the Bids and Proposals web page, located at www.lvks.org.

Evaluation of Proposals

All proposals submitted in response to this Request for Proposal become the property of the City of Leavenworth, unless expressly identified as proprietary. Proposals will be evaluated by City staff. It will be based upon the following criteria set forth below. All proposals submitted will be the primary document upon which each proposal will be evaluated. All proposals will first be screened to determine minimum qualifications as outlined in the RFP. Proposals that do not meet these minimum requirements will automatically be rejected and shall not undergo further evaluation.

Submitted proposals will be evaluated and weighted with the following criteria:

1. Content Management System (CMS) Technical (Appendix B Section A) (Weight 30%)

-
2. Content Management System (CMS) - Design Components and Tools (Appendix B Section B) (Weight 25%)
 3. Website Design (“look and feel”) samples that will support the City’s brand and marketing needs of specific departments/services. Web (Appendix B Section C) (Weight 20%)
 4. Education and Training (Weight 10%)
 5. Implementation Plan (Weight 10%)
 6. Experience and Reference - Government references provided by vendor. These references must cite vendor’s work experience and product. (Weight 5%)
 - a. (Additional References) Lotus Notes references provided by vendor. These references must cite vendor’s work experience and product migrating from and integrating with Lotus Notes.

Candidates should plan to be available if interviews and/or demos are needed. Depending on the responses to this RFQ and short list interview, the City may select more than one firm or individual for interviews.

This Request for Proposal does not commit the City of Leavenworth to award a contract or pay any cost incurred in preparation or for travel. Any contract that may be awarded in response to this Request for Proposal shall be considered, selected and offered at the complete and sole discretion of the City. The City reserves the right to accept or reject any or all proposals received or to cancel this Request for Proposal in part or in its entirety. The City reserves the right to waive any and all irregularities or informalities in the proposal content, manner or method of delivery, or consideration of proposals.

Appendix A - Contract Submittal Addendums

The City is requesting sample contract documents and vendor compliance to the following addendums to contract language. Should we enter into a contract with a potential vendor, said contract must contain acceptance of the following addendums.

A) KAAD provisions of KSA 44-1030(a)

During the performance of this Agreement, and any resulting subcontract, “Vendor Name”, all subcontractors and, shall observe the provisions of the Kansas Act Against Discrimination (K.S.A. 44-1001, et seq.) and Title VII of the Civil Rights Act of 1964 as amended, and shall not discriminate against any person in the performance of work under this Agreement because of race, religion, color, low income, age, sex, disability, national origin or ancestry. In all solicitations or advertisements for employees, “Vendor Name”, all subcontractors, shall include the phrase, “equal opportunity employer,” or a similar phrase approved by the Kansas Human Rights Commission.

If “Vendor Name” fails to comply with the manner in which “Vendor Name”, reports to the Kansas Human Rights Commission in accordance with the provisions of K.S.A. 44-1031 and amendments thereto, “Vendor Name” shall be deemed to have breached this Agreement, and this Agreement may be canceled, terminated or suspended, in whole or in part, by the Client.

If "*Vendor Name*", is found guilty of a violation of the Kansas Act Against Discrimination under a decision or order of the Kansas Human Rights Commission which has become final, "*Vendor Name*" shall be deemed to have breached this Agreement, and this Agreement may be canceled, terminated or suspended, in whole or in part, by the City of Leavenworth.

"*Vendor Name*" shall include the provisions of this Section in every subcontract or purchase order to ensure these provisions will be binding upon such subcontractor or vendor.

B) Additional Contract Term

The successful Vendor shall not subcontract any of its obligations under the contract with the City, without the City's prior written consent. The City will have the right to require the removal and replacement of any personnel of the successful Vendor or the successful Vendor's subcontractors who are assigned to provide Services to the City. The City shall be entitled to exercise such right in its sole discretion by providing written notice to the successful Vendor.

The successful Vendor shall not disclaim any statutory or implied warranties that products or services will be fit for the intended purposes set forth in the Request for Proposals or the Proposal

The successful Vendor shall not request a waiver or limitation on any damages provided for under Kansas law.

C) Insurance

"*Vendor Name*" shall secure and maintain throughout the duration of this Agreement with the City, and maintain, for a period of two (2) years from the date of final payment for the work to be performed under the Agreement (on an occurrence basis unless otherwise agreed to by the City in writing), such types and amounts of insurance as required herein from an insurance company licensed to do business in the State of Kansas and from a company which carries a Best's Policyholder rating of "A-" or better, with certification on standard ACORD™ forms provided to the City and with copies of all endorsements pertaining to the City.

The insurer shall agree to provide a Waiver of Subrogation in favor of the City for each policy providing coverage required by this Agreement, waiving all rights of subrogation against the City, its directors, officials, officers, employees, agents and contractors for losses paid under the terms of the insurance policy which arise from work performed by "*Vendor Name*". If the policy requires an endorsement to implement the waiver of subrogation, "*Vendor Name*" shall cause the endorsement to be made and shall provide a copy of the endorsement prior to beginning any work under this Agreement.

Coverage on the Commercial General Liability and the Automobile policy shall be primary and noncontributory and shall be so stated on the Certificate.

In the event of an occurrence, it is further agreed that any insurance maintained by the City, shall apply in excess of and not contribute with insurance provided by policies named in this Agreement.

Exposure Limits: The above are minimum acceptable coverage limits and do not infer or place a limit on the liability of "Vendor Name" nor has the City assessed the risk that may be applicable to "Vendor Name". "Vendor Name" shall assess its own risks and if it deems appropriate and/or prudent maintain higher limits and/or broader coverage's.

COMMERCIAL GENERAL LIABILITY

Protection limits of at least \$1,000,000 Combined Single Limit per occurrence and \$1,000,000 annual aggregate, bodily injury and property damage, including Products and Completed Operations. This insurance shall include coverage for products, operations, personal injury liability and contractual liability, assumed under the indemnity provision of this Contract.

The City will only accept coverage from an insurance carrier who offers proof that it:

- Is licensed to do business in the State of Kansas;
- Carries a Best's policy holder rating of "A-" or better; and
- Carries at least a Class VII financial rating, or is a company approved by the City.

AUTOMOBILE LIABILITY

Policy shall protect "Vendor Name" against claims for bodily injury and/or property damage arising out of the ownership or use of any owned, hired and/or non-owned vehicle and must include protection for either:

1. Any Auto; or
2. All Owned Autos; Hired Autos; and Non-Owned Autos

Limits of auto liability insurance shall be the same as required per occurrence in the Commercial General Liability section, and shall include the Hired and Non-Owned liability coverage.

WORKER'S COMPENSATION

This insurance shall protect "Vendor Name" against all claims under applicable state workers compensation laws. "Vendor Name" shall require and verify all subcontractors maintain coverage through Independent Contractor or a separate policy. "Vendor Name" shall also be protected against claims for injury, disease, or death of employees which, for any reason, may not fall within the provisions of a worker's compensation law. The policy limits shall not be less than the following:

Workers' Compensation:	Statutory
Employer's Liability:	
Bodily Injury by Accident:	\$ 500,000 Each Accident
Bodily Injury by Disease:	\$ 500,000 Policy Limit
Bodily Injury by Disease:	\$ 500,000 Each Employee

ERRORS AND OMISSIONS LIABILITY

Errors and Omissions Liability Insurance as shall protect "Vendor Name" and employees from claims alleging the failure to provide the services required by this Agreement. This policy shall be specific to the performance of this Agreement and shall provide limits of \$1,000,000 each occurrence/aggregate. Proof of this policy of insurance shall be submitted to the City before any work is commenced under this Agreement.

±

ELECTRONIC ERRORS AND OMISSIONS

If the risks typically covered by Electronic Errors and Omissions Insurance are not covered by "Vendor Name" Errors and Omissions Insurance, "Vendor Name" shall purchase an electronic errors and omissions insurance policy having aggregate limits of \$1,000,000 and occurrence/aggregate limits of \$1,000,000, respectively.

D) Agreement to Indemnify and Warrant

Vendor warrants that the product will not violate, infringe or misappropriate any patent, copyright, trademark, trade secret rights of any third party or any other third party rights including non-compete agreements. Vendor warrants it shall not violate any agreement with any third party by entering into or performing this Agreement. Vendor warrants that the work product will be delivered and shall remain free of any lien or encumbrance. If vendor becomes subject to a claim against it that any portion of the work product supplied by vendor infringes a proprietary right of a third party, vendor shall, with respect to and to the extent of the portion of the claim pertaining to such work product, at its sole expense, defend, indemnify and hold harmless the City with respect to such claim and all costs, expenses (including reasonable attorneys' fees), fines, penalties, deficiencies, losses, liabilities (including settlements and judgments) resulting from, arising from or relating to such claim.

Appendix B - Web Project Technical Requirements

A) CMS System Technical

1. Scheduling of Content
2. Workflow for Content and promotion - Implementation of an electronic workflow for all proposed website changes for approval and promotion
3. Look and feel (GUI) of the CMS
4. WYSIWYG editor
 - a. CMS software which contains a WYSIWYG editor, tools, & components
 - b. Ability to limit features of WYSIWYG editor to maintain common look and feel throughout the website
5. CMS infrastructure design (SQL, Front end, Server(s), network, etc.)
6. Spell checker
7. Ability to organize, manage, and optimize uploaded documents and images, as well as animations
8. Publishing workflow with the ability to customize by groups
9. Audit Trails of content changes as well as design changes
10. Template Design - Extensive flexibility in page layout options, and page design templates
11. Active link verification
12. Ability to preview pages prior to publishing
13. Ability to secure content to specific authors
14. Ability to allow for future dating of publishing and expiring of content
15. Archival and retrieval of expired content
16. Interactive - charts and graphs (Big Data)
17. CMS is scalable and allows for future growth
18. Easy adoption by staff with different technical abilities

-
19. Custom URLs or simple URLs
 20. Allow for continuation of use for citizens to report code violations, purchase many permits from the City Clerk (i.e. Garage Sale Permits) and have a management system for such citizen requests and actions.

B) Design Components and Tools

1. Mobile First - "Responsive Design"
2. Single Site design. No mobile site - One repository for mobile and traditional web environment
3. Open Source CMS solution or a proprietary CMS software use
4. State the development platform if using Open Source CMS software and cite your experience working with this software. Examples of Open Source CMS software are listed below:
 - a. Wordpress
 - b. Drupal
 - c. Omeka
 - d. CollectiveAccess
 - e. CIVICRM
 - f. Other
5. Flexibility in page layout and navigation
6. UI/UX Manager Experience (User Interface/User Experience)
7. Data Migration Tools
8. Social Media integration with appropriate tags in documents
9. Full Site Search - provide a strong web site search design
 - a. Full site and PDF searching capabilities – to include all sources of content
10. Security overview of CMS to include role-driven security with regard to content editing
11. Briefly describe workflow concepts and capabilities
12. Meets U.S. Federal Government ADA requirements
13. Design recommendations as it related to multiple domains vs combining into one domain
14. On premise and cloud hosting solutions
 - a. Identify the benefits and liabilities for Cloud and On Premise solutions
15. Site hosting (Cloud or On Premise)
 - a. Please explain if re-selling or fully hosting
 - b. Cloud - appropriate redundancy and scalability to avoid unexpected outages and to accommodate periodic maintenance, usage growth and spikes
 - c. Flexible or adaptable performance to meet ISP pipe/bandwidth demands (Hosted solutions)
 - d. Hosted Security features (penetration testing, DDOS) to prevent unauthorized access to web content

C) Web

1. "New Look and Feel" designs: Provide samples of proposed look and feel designs in support of the City's web sites. Preferred samples would be active URLs showing a sampling of the City's content in new "new look and feel" layouts. Such links would be responsive in design. Hardcopy designs sample would be accepted for this RFQ.
2. Emphasis should support the City's branding
3. ADA Compliance components - User experience and Section 508/ADA compliance

-
4. Analytics Features - including necessary codes installed for tracking
 5. Embedded view/URL
 6. Call or Query data elements that can render changing data
 7. Dynamic Data set up - How with to address with Cloud
 8. Full integration with Leavenworth's web applications (Hosted and on premise applications)

See below attachments: Affirmative Action requirements, Non-collusion Affidavit, and Insurance requirements.

**AFFIRMATIVE ACTION REQUIREMENTS
FOR CITY CONTRACTS UP TO \$100,000**

Equal Opportunity in employment is the policy of the City of Leavenworth, Kansas, and the City has particular interest in assuring Equal Opportunity Employment among contractors doing business with the City. In recognition of its interest and concern, the City Commission on April 24, 1984 adopted Resolution B-813 establishing an Affirmative Action Policy for the City of Leavenworth, Kansas.

“Any proposal in the amount of up to \$100,000 shall be accompanied by a written certification that during the performance of said contract the Contractor agrees not to discriminate against any employee or applicant for employment with such Contractor. In addition, every Contractor shall include a similar provision in all subcontracts under his or her contracts with the City of Leavenworth. Said written certification shall include a statement that the Contractor is an equal employment opportunity employer, and agrees not to discriminate against any employee on the basis of race, sex, color, religion, disability, age, national origin, or ancestry.”

EXHIBIT 1

(Suggested format only)

(Date)

It is the employment policy and practice of _____ to recruit and to hire employees without discrimination because of race, sex, color, religion, age, disability, national origin or ancestry, and to treat all employees equally with respect to compensation, and opportunities for advancement including upgrading, promoting and transfer; and all other terms and conditions of employment.

In furtherance of these policies and practices, this company has designed and agreed to implement an Affirmative Action Program in accordance with the provisions of Resolution B-813 of the City of Leavenworth, Kansas.

This company has agreed to assert leadership with the community and put forth the maximum effort to achieve full employment plus the utilization and development of the capabilities and productivity of all our citizens.

This company will implement this Affirmative Action Program in a positive and aggressive manner and will make known our commitment to this effort. We will solicit and encourage all persons to seek opportunities with this company, and to take advantage of all advancement possibilities.

(Signature)

(Title)

(Company)

NON- COLLUSION AFFIDAVIT

The undersigned bidder or agent, being duly sworn on oath, say that he/she has not, nor has any other member, representative, or agent of the firm company, corporation or partnership represented by him, entered into any combination, collusion or agreement with any person relative to the price to be bid by anyone such letting nor to prevent any person from bidding nor to include anyone to refrain for bidding, and that this bid is made without reference to any other bid and without any agreement, understanding or combination with any other person in reference to such bidding.

He/ She further says that no person or persons, firms or corporation has; have to will receive directly, any rebate, fee gift, commission or thing of value on account of such of sale.

OATH AND AFFIRMATION

I HEREBY AFFIRM UNDER THE PENALTIES FOR PERJURY THAT THE FACTS AND INFORMATION CONTAINED IN THE FOREGOING BID FOR PUBLIC WORKS ARE TRUE AND CORRECT.

Dated this ____ day of _____, _____

(Name of Organization)

(Title of person signing)

(Signature)

ACKNOWLEDGEMENT

STATE OF _____)

SS

COUNTY OF _____)

Before me, a Notary Public, personally appeared the above name and swore that the statements contained in the foregoing document are true and correct.

Subscribed and sworn to me this ____ day of _____, _____.

Notary Public Signature

My Commission Expires: _____

INSURANCE

The Contractor shall secure and maintain such insurance as will insure the performance by the Contractor of its obligations to protect, defend, indemnify and hold harmless Owner and officers and agents of the Owner and Contractor respectively, as provided herein, and will protect them from claims under Worker's Compensation Acts; automobile liability for bodily injury(including death) or property damage; and general liability for bodily injury(including death) or property damage which may arise from and during operations under this contract, whether such operations be by itself or anyone directly or indirectly employed by it.

The Contractor shall purchase and maintain in full force and effect during the term of this contract, insurance in a company or companies satisfactory to the Owner, but regardless of such approval, it shall be the responsibility of the Contractor to maintain such coverage and shall not relieve Contractor of any contractual responsibility or obligation. Insurance of the following types and with the following limits are required:

General Liability:

The minimum limits of liability for commercial general liability insurance shall be:

\$1,000,000 each occurrence for bodily injury or property damage;

\$2,000,000 general aggregate with a per-project endorsement; and

\$1,000,000 products/completed operations aggregate.

Each such policy shall include comprehensive forties, contractual liability, independent Contractors, products/completed operations, inherently dangerous activities, premises-operations, broad form property damage, and personal injury coverage.

General Liability coverage shall name Owner as an Additional Insured on a primary basis, per the CG 2010 11/85 or its equivalent, or a combination of CG 2010 10-01 and CG 2037 10-31 (including products and completed operations).

The coverage's shall provide protection for the Contractor and the Owner against liability from damages because of injuries, including death, suffered by any person and liability from damages to property, arising from or growing out of the Contractor's operations in connection with the performance of this contract. All insurance required by this contract shall remain in force until all work required to be performed under the terms of the contract is satisfactorily completed as evidenced by its formal acceptance. Each policy shall also contain a severability of interest conditions and the insurance afforded by the Contractor shall be primary insurance.

The Contractor shall provide the Owner with a Certificate of Insurance, specifying Contractor's insurance coverage and limits before any work is performed under this contract. A Certificate of Insurance shall also be provided upon each policy renewal. Certificates of Insurance shall be sent to Owner at the address stated herein. Such proof of insurance shall provide for ten (10) days prior written notice to the Owner before cancellation, termination or material change or modification of such insurance, unless longer advance notice is required by the Owner. Such notice shall be given to Owner at the address above noted. Consulting Engineer shall be listed as an additional insured on the liability insurance policies. Upon request Contractor shall furnish certified copies of any insurance policies listed in the Certificate of Insurance.

If Contractor shall subcontract any of this work to a third party, Contractor shall see to it that such third party maintains such insurance and shall furnish evidence thereof to Contractor and Owner. Subcontractor shall cause all such policies of insurance to name Contractor and Owner as additional insured's and provides indemnification for Contractor and Owner against liability upon the risks insured thereby to the amount of the coverage specified therein for Contractor.

If the Contractor has a policy or policies of insurance with aggregate limits of liability Owner must be notified in writing any time the aggregate limit is diminished materially below the coverage required by this contract.

Contractor shall notify Owner in writing 10 days after it receives notice or knowledge of any demand, claim, cause of action, lawsuit, or action arising out of the work performed under this contract. Contractor shall notify Owner as soon as possible after any bodily injury or property damage occurrence that could potentially lead to any lawsuit.

All liability insurance shall be occurrence policies in a form acceptable to Owner. Claims-made policies are not acceptable.

Automobile Liability:

Contractor shall obtain automobile liability insurance, which provides coverage for its owned, non-owned, and hired vehicles of every type and description, which are used in the contract work. The minimum limits of liability for such insurance shall be:

\$1,000,000 combined single limit for bodily injury and property damage

Workers Compensation:

Statutory

Employers' Liability:

\$100,000/\$500,000/\$100,000(each accident/disease-policy limit/disease-each employee)

Builders Risk/Installation (if required by Owner):

For direct physical loss or damage to covered property while under construction at the premises described in the declaration of the policy and per specifications. Limit of coverage is the contract bid to be in force for the duration of the project and until the project is accepted by the Owner. The Owner will be named additional insured.

Umbrella Coverage (if required by Owner):

An umbrella coverage will be required if the project costs are over \$2 million.

Waiver of Subrogation:

Contractor waives any and all subrogation claims, including such claims arising out of injuries to Contractor's employees, against Owner, Engineer, and Consulting Engineer and their respective officers, directors, partners, employees and agents.

Response to RFP-2018-10 City Website Design and Replacement

City of Leavenworth, Kansas



municode
★
CONNECTING YOU & YOUR COMMUNITY



Bob Geiger

PO Box 2235 Tallahassee, FL 32316
801.643.1806 bgeiger@municode.com

Table of Contents

Table of Contents	2
Executive Summary	3
Vendor Profile	4
Project Staff Background / Project Management	5
Experience and References	7
Implementation Plan / Education / Training	10
Contract Terms	13
CMS Technical (Appendix B Section A).....	15
CMS Design Components and Tools (Appendix B Section B)	19
Web (Appendix B Section C).....	23
Exceptions and Variances.....	24
Pricing	25

Executive Summary

This proposal outlines our plan-of-attack to provide City of Leavenworth and the Convention and Visitor's Bureau with a professional and mobile-friendly web presence according to the requirements outlined in your RFP. On the pages that follow, we provide specific details regarding our professional team, our best-in-class municipal website CMS features, and our proposed approach.

Goals

We read your RFP requirements in detail and we understand your goals and priorities. We intend to deliver a website that meets and exceeds those goals. Specifically, we guarantee that your new web presence achieves the following objectives:

- ☑ **Dynamic Designs** – we will work diligently to provide professional and visually dynamic designs to improve Leavenworth's image and profile and accentuates your strategic communication objectives.
- ☑ **Ease of Use** – our CMS and award-winning designs have proven to be among the easiest in the industry for both citizens and staff. Our Drupal-based authoring tool is simple and straight-forward.
- ☑ **Mobile Friendly** – our solution leverages responsive design to work seamlessly on phones and tablets
- ☑ **ADA Compliance**– In addition to testing your site for WCAG 2.0 AA ADA compliance prior to initial launch, we offer ongoing ADA compliance checks and error-correction.

Why Us?

We value the opportunity to strengthen our relationship with Leavenworth. As a current Municode customer for codification services, we are committed providing a web solution that offers the best combination of professional design, simplicity for residents, and simplicity for staff. A few of the specific features offered in our solution that stand out against our peers include:

- ☑ **A best-in-class search engine** – Includes file attachment indexing, advanced filters that filter by department / date, and integrates with our other online Code of Ordinances solution and our Meeting and Agenda Management solution.
- ☑ **Unique staff ease-of-use features** – Staff can create a page once and it will auto-populate in multiple site locations.
- ☑ **Robust calendar and meetings**– A simplified interface for creating meetings, attaching meeting files, and integration with a master calendar.
- ☑ **Open source solution** – Our solution is based on the industry-leading Drupal open source CMS. It is non-proprietary. You truly own the code.
- ☑ **Commitment to customer service** – We are here long-term to provide you with first-rate support via the phone, email, and web teleconference. We are committed to strengthening our partnership with you.

Vendor Profile

History, Mission, and Team

With over 65 years of experience, Municode's mission is to connect public sector organizations with their communities. Our solutions promote transparency and efficiency - such as custom website design, meeting and agenda management, online payment portals, the legal codification process, and our robust suite of online legislative search tools.

Municode has been in business for over sixty-five years and partners with more than 4,500 government agencies across all fifty states.

Municode is a privately-owned corporation and is financially sound with no debt. Our leadership focuses on improving Municode through investments in its people and its technology. Our culture is conducive to the longevity of our employees; Our clients can establish a long-term partnership with our experienced and stable workforce.

Municode is home to over 230 employees (most of whom enjoy a 10+ year tenure). Our headquarters in Tallahassee, Florida includes four buildings totaling 56,000 square feet. Our West Coast office is located just south of Portland in Lake Oswego, Oregon. We also have individual team members working in several states across the country.



Our Vision: Simple, Seamless Integration

Our vision is to create seamless integration between our service offerings. The goal is to reduce staff workload, while at the same time, increasing the ability for municipalities to connect with their communities.

The following example integration points are either in place today or envisioned in our future strategic roadmap.

- Unified search across all platforms (website, meetings, online codes)
- Auto-publish agendas and minutes from the Meetings platform to the Website
- Ordinance auto-publishing from the Meetings platform to your online code, queued for supplementation
- Code of ordinance cross-references to legislative voting history, minutes, and video/audio



4,500

Municipal Clients

65+ Years

Serving Municipalities

180 Million

Citizens using our solutions

Project Staff Background / Project Management

Dave Fels will act as your project lead and he will be supported by six team members. Brian Gilday, president of Municode's website division, will serve as the project sponsor and point of escalation in the unlikely event issues are not resolved to your satisfaction.

Organizational Structure

1. Project Sponsor (Brian)

- Project Lead (Dave)

- i. Project Team

- Design Leadership / User Experience / Content Strategy (Dave)
- Content Migration (Lois)
- Development (Mitchel)
- Quality Assurance / Analytics (Kristin)
- Graphic Design (Drago)
- Performance / Systems Administration (Paul)
- Marketing / Awards / PR (Jorrdan)



Brian – Project Sponsor

Brian is an information technology expert, former U.S. Naval Officer, and former Big 5 consultant with Deloitte Consulting. He holds a BS in Computer Science with distinction from the United States Naval Academy (Annapolis, MD) and an MS in CIS from Boston University. Brian served as an Associate Professor at MIT and Boston University.



Dave – Project Management / User Experience / Content Strategy

Dave has a Bachelor of Arts degree in Communications from California State University. In addition to project and design leadership, Dave participates in various analytical, site configuration, content migration, and training activities. Dave is a certified User Experience expert.

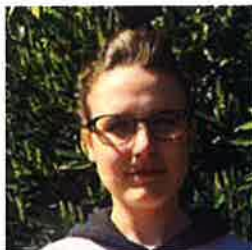

Lois Keilwitz – Content Authoring / User Experience

Lois graduated from Washington State University Vancouver and received a Bachelor of Arts in Management and Information Systems. Lois will participate in customer support efforts, content migration, and quality assurance.



Mitchell – Development

Mitchel graduated from Oregon State University with a Bachelor of Science in Business Information Systems and a minor in Computer Science. As a Business System Analyst, Mitchel builds custom features, migrates data, fixes minor issues, and helps with support.



Kristin Park – Quality Assurance / Analytics

Kristin graduated from Washington State University with a Bachelor of Arts in Management Information Systems and Accounting. As a Business System Analyst, Kristin will be building custom features, migrating data, and providing support to clients.



Paul – Systems Architecture

Paul has worked on software systems for years and is a strong member of our team. We turn to Paul for any custom development work that might be required. In addition, Paul has many years of experience in quality assurance testing, so he acts as Municode's lead tester for the engagement.



Drago – Graphic Design

Drago's work speaks for itself. He has the unique ability to capture the essence of your branding and communication requirements and transform them to stunning web designs.



Jorrdan – Marketing / Awards / PR

Jorrdan creates press releases for our clients to help promote their website redesign and guides our clients through the process of applying for national and international website awards. She also helps us with case studies, testimonials, and blogs. She has a bachelor's degree from Florida State University in English, Creative Writing and Communications.

Experience and References

There is a reason why we have loyal customers! It is because we have a great solution, we take care of our customers, and we are committed to working with you for the long haul. When you pick up the phone and call us, we answer! When you email, we respond quickly – usually within 30 minutes. When you need us, we will be there for you. **But don't take our word for it, ask our most recent clients.**

Corvallis Oregon - 2017

[Vision Internet replacement]

<https://www.corvallisoregon.gov>

Population: 55,298

Patrick Rollens, Public Information Officer

541-766-6368

patrick.rollens@corvallisoregon.gov



Naples Florida - 2017

[Civic Plus replacement]

<https://www.naplesgov.com>

Population: 20,115

David Fralick, Communications Manager

239-213-1054

dfralick@naplesgov.com



AWARD WINNER! NAGW
Member's Choice Award – Best
Website in Nation for
Municipalities 40,000 and Under



Brookhaven Georgia - 2017

[Vision Internet replacement]

<https://www.brookhavenga.gov>

Population: 52,444

Ann Marie Quill, Communications Manager

404-637-0508

annmarie.quill@brookhavenga.gov



Los Altos CA - 2017

<https://www.losaltosca.gov>
Population: 30,010

Erica Ray, PIO
650-947-2611
eray@losaltosca.gov



Foster City CA - 2017

<http://www.fostercity.org>
Population: 30,567

Rob Lasky, IT Director
650-286-3216
rlasky@fostercity.org



Milwaukie Oregon - 2017

<http://www.milwaukieoregon.gov>
Population: 20,291

Hannah Wells, Webmaster
503-786-7545
wellsh@milwaukieoregon.gov



White Bear Lake Minnesota - 2017

<http://www.whitebearlake.org>
Population: 23,769

Kara Coustry, City Clerk
651-429-8508
kcoustry@whitebearlake.org



Great Falls Montana - 2017

<http://www.greatfallsmt.net>
Population: 59,351

Rachel Arms, Webmaster
406-455-8445
rarms@greatfallsmt.net



Specialty Sub-Site Graphic Designs

We also offer the option of having graphic designs for sub-sites that require specialized branding. We call these 'specialty sub-sites'. We leverage your main CMS and database, which allows us to offer these sub-sites with the same functionality as your main site yet with a completely different look and feel.

Economic Development

www.choosewoodstock.com

<https://www.fluvannacounty.org/ced>



Parks & Recreation

www.cprdnewberg.org

www.cityofvancouver.us/parksrec



Festivals

www.wintermusicfestival.org



Libraries

www.woodstockpubliclibrary.org

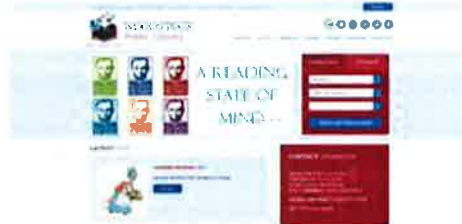

Police and Fire

www.mvfpd.org

www.quincypd.org

www.co.benton.or.us/sheriff



Event Centers / Cultural Centers

www.eventcenter.org

www.woodstockoperahouse.com

www.sherwoodcenterforthearts.org



Golf Courses

www.meadowlakesgc.com



Tourism

www.gofruita.com



Implementation Plan / Education / Training

The typical project takes from 3 to 6 months. The high-level timeline below is an approximation. We will finalize the schedule once we meet with you:

Project Timeline Sample

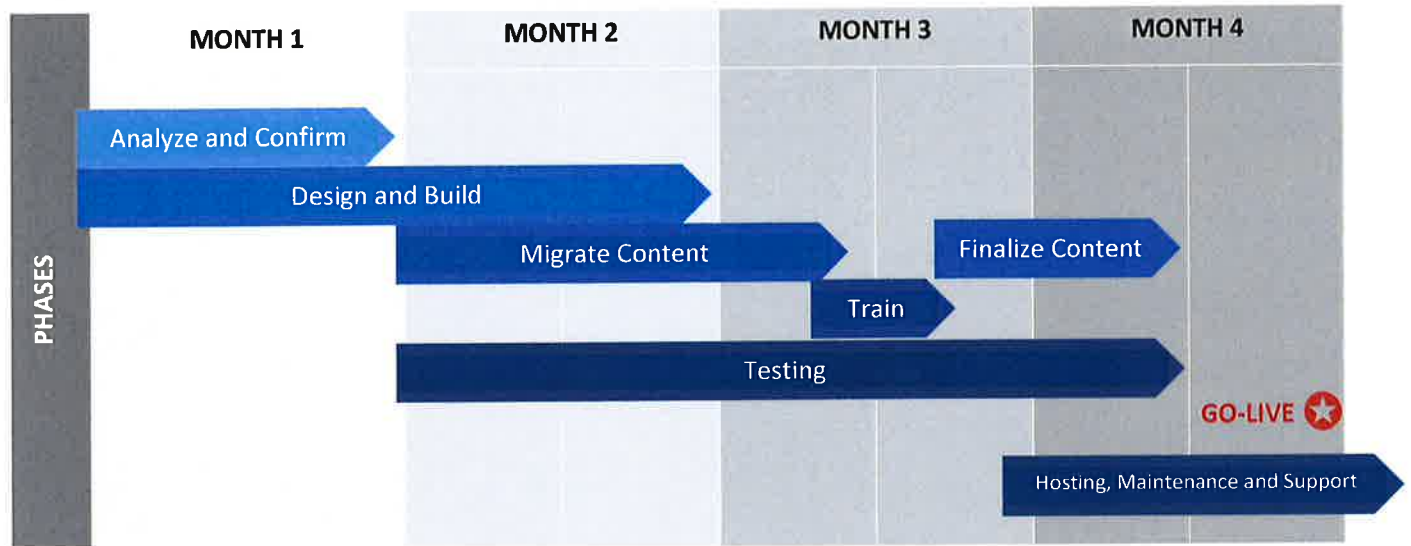

Client Responsibilities

The client's responsibility and the key to a smooth on-time deployment is providing the initial information and approving proofs quickly.

- ☑ The Client will make available to Municode relevant images, photos, logos, colors, and other branding material as well as an inventory of existing applications, websites, and content at the start of this effort. The Client will create new content copy as needed.
- ☑ The Client will assign a single point of contact for Municode to interact with that will be responsible for coordinating the schedules of other project stakeholders.
- ☑ The Client will review any deliverables requiring formal approval within 5 business days and return all comments/issues at or before those 5 days have elapsed.
- ☑ The Client will assign one person who will act as the "ultimate decision maker" in the case where consensus among the team cannot be reached.
- ☑ The Client must agree to applicable terms of services for Google related services such as Google Analytics and Google Maps to access those features. Municode is not responsible for Google's decisions related to discontinuing services or changing current APIs.

Project Phase Descriptions

Phase 1: Analyze and Confirm Requirements

Website Assessment:

Municode will complete an analysis of your current website(s) to assess the existing navigation, features/functions, and quality of content.

Organizational Overview Inventory/Survey:

Municode will provide an organizational overview document for you to complete as part of this assessment.

Website Design Meeting:

Municode will conduct a design meeting with a client-defined web advisory team. We recommend the advisory team be limited to a maximum of 6 members. This design meeting will allow the website advisory team to provide input regarding the overall design of the new website, including the site branding as well as high-level site navigation. This team will act as the initial review team for website design concepts. In addition, this team will act as the final review team for the website before it is approved for go-live.

Deliverables

- Summary assessment sheet
- Organization Survey
- Website design specification sheet (graphic design and information / navigation design)

Phase 2: Design and Build phase

Design Concept Creation and Approval (Custom Designs):

Municode will complete home page design concepts for the Home Page and inner pages. These design concepts will incorporate all the graphical elements as well as the high-level sitemap. You will select a winning concept after going through a series of iterative design revision meetings. We allow for a total of 6 revisions.

Website Setup, Configure, and Customization:

Municode will create a fully functional website that includes the functional elements described in this proposal. As part of the website setup, Municode will finalize any remaining elements to the approved design and navigation.

Deliverables

- Design concepts
- Finalized design (Photoshop PSD)
- Functional beta website with approved design
- Content migration

Phase 3: Migrate Content

Content Finalization and Departmental Acceptance

Municode migrates initial content and your trained staff finalizes prior to go-live. See pricing section for specific number of included pages.

Meeting Agendas and Minutes: Client completes an excel template with information regarding each meeting plus corresponding files. Municode will then auto-import that content. Files must be provided with a standard naming convention to allow for auto parsing of date. (i.e. minutes_061516.pdf, etc.)

Standard Web Pages: A standard web page is defined as a page that contains a title, body text, and up to a total of 5 links, file attachments, or images. If you require migration of more complex pages, we can provide a custom quote.

Directory pages (Staff Directory, Projects, Commercial/Industrial Properties, Business Directory, Ordinances/Resolutions): Client completes manually or may request a custom quote. For custom quotes, client completes an excel template with directory data and Municode auto-imports directory content.

Deliverables

- ⦿ Content creation and migration
- ⦿ Departmental content 'signoff'

Phase 4: Staff Training

Staff Training

Throughout the development and after launch, our customers have access to training, resources and educational opportunities that help them thrive. Our initial training is offered to administrators and content contributors.

Deliverables

- ⦿ On-site (if applicable)
- ⦿ Web teleconference
- ⦿ Videos and User guides

Phase 5: Testing

Municode Functional Testing

Municode will perform a series of tests across multiple browser and operating system versions to confirm site functionality. Test will confirm proper functionality of all features documented in this proposal.

Acceptance Testing

Staff will review the website for completeness. Municode will have completed functional testing and cross-browser compatibility testing.

Deliverables

- ⦿ Completing Testing Checklists
- ⦿ Site acceptance by client

Go Live ★

Go-Live

We will work with you to make the appropriate 'A' Record DNS entry changes to begin the process of propagating the new production web server IP address.

Deliverables

- ⦿ Accepted Final Live Website

Contract Terms

This agreement ("AGREEMENT") is entered between the City of Leavenworth, Kansas ("CLIENT") and Municipal Code Corporation ("CONSULTANT").

1. Term of AGREEMENT. This AGREEMENT shall commence effective the date signed by the CLIENT. It shall automatically renew annually. This AGREEMENT shall terminate upon the CLIENT's providing CONSULTANT with sixty (60) days' advance written notice

2. Compensation. It is understood and agreed by and between the parties hereto, that the CLIENT shall pay the CONSULTANT for services based on the payment schedule provided as set forth in the section marked "Payment Schedule". Payment will be made to CONSULTANT within thirty (30) days of the receipt of approved invoices for services rendered.

3. Scope of Services. CONSULTANT's services under this AGREEMENT shall consist of services as detailed in the attached proposal including appendices ("SERVICES"). SERVICES may be amended or modified upon the mutual written AGREEMENT of the parties.

4. Integration. This AGREEMENT, along with the SERVICES to be performed contain the entire agreement between and among the parties, integrate all the terms and conditions mentioned herein or incidental hereto, and supersede all prior written or oral discussions or agreements between the parties or their predecessors-in-interest with respect to all or any part of the subject matter hereof.

5. Warranty. CONSULTANT warrants that any services provided hereunder will be performed in a professional and workmanlike manner and the functionality of the services will not be materially decreased during the term.

6. Liability. CONSULTANT's total liability arising out of any acts, omissions, errors, events, or default of CONSULTANT and/or any of its employees or contractors shall be limited by the provisions of the AGREEMENT and further limited to a maximum amount equal to the fees received by CONSULTANT from CLIENT under this AGREEMENT.

7. Termination. This AGREEMENT shall terminate upon the CLIENT's providing CONSULTANT with sixty (60) days' advance written notice. In the event the AGREEMENT is terminated by the CLIENT's issuance of said written notice of intent to terminate, the CONSULTANT shall pay CLIENT a pro-rated refund of any prepaid service fees (for the period from the date of the termination through to the end of the term). If, however, CONSULTANT has substantially or materially breached the standards and terms of this AGREEMENT, the CLIENT shall have any remedy or right of set-off available at law and equity.

8. Independent Contractor. CONSULTANT is an independent contractor. Notwithstanding any provision appearing in this AGREEMENT, all personnel assigned by CONSULTANT to perform services under the terms of this AGREEMENT shall be employees or agents of CONSULTANT for all purposes. CONSULTANT shall make no representation that it is the employee of the CLIENT for any purposes.

9. Confidentiality. (a) Confidential Information. For purposes of this AGREEMENT, the term "Confidential Information" means all information that is not generally known by the public and that: is obtained by CONSULTANT from CLIENT, or that is learned, discovered, developed, conceived, originated, or prepared by CONSULTANT during the process of performing this AGREEMENT, and relates directly to the business or assets of CLIENT. The term "Confidential Information" shall include, but shall not be limited to: inventions, discoveries, trade secrets, and know-how; computer software code, designs, routines, algorithms, and structures; product information; research and development information; lists of clients and other information relating thereto; financial data and information; business plans and processes; and any other information of CLIENT that CLIENT informs CONSULTANT, or that CONSULTANT should know by virtue of its position, is to be kept confidential.

(b) **Obligation of Confidentiality.** During the term of this AGREEMENT, and always thereafter, CONSULTANT agrees that it will not disclose to others, use for its own benefit or for the benefit of anyone other than CLIENT, or otherwise appropriate or copy, any Confidential Information except as required in the performance of its obligations to CLIENT hereunder. The obligations of CONSULTANT under this paragraph shall not apply to any information that becomes public knowledge through no fault of CONSULTANT.

10. Assignment. Neither party may assign or subcontract its rights or obligations under this AGREEMENT without prior written consent of the other party, which shall not be unreasonably withheld. Notwithstanding the foregoing, either party may assign this AGREEMENT in its entirety, without consent of the other party, in connection with a merger, acquisition, corporate reorganization, or sale of its assets.

11. Cooperative Purchasing. CONSULTANT and CLIENT agree that other public agencies may purchase goods and services under this solicitation or contract at their own cost and without CONSULTANT or CLIENT incurring any financial or legal liability for such purchases.

12. Governing Law. This AGREEMENT shall be governed and construed in accordance with the laws of the State of Kansas without resort to any jurisdiction’s conflicts of law, rules or doctrines.

Submitted by:

Municipal Code Corporation

By: *Brian Gilder*

Title: President, Municode WEB

Accepted by:

By: _____

Title: _____

Date: _____

CMS Technical (Appendix B Section A)

Municode Web - Standard Features

Municode Web was designed for local governments by experts in local government. It utilizes Drupal, an open source platform that powers millions of websites and is supported by an active, diverse, and global community. We are the Drupal experts for local government!

- ⊙ Responsive Mobile Friendly Design
- ⊙ Simple Page Editor
- ⊙ Best-in-Class Search Engine
- ⊙ ADA/Section 508 Compliance
- ⊙ Social Media Integration
- ⊙ Web Page Categories - create a page once, have it show up in multiple places
- ⊙ Department Micro-sites (sites-within-a-site)
- ⊙ Rotating Banners and Headline Articles
- ⊙ Online Job Postings
- ⊙ Online Bid/RFP Postings
- ⊙ Photo Album Slideshows
- ⊙ Google Maps Integration
- ⊙ Resource/Document Center
- ⊙ Image auto-scaling and resizing
- ⊙ Site Metrics (Google Analytics)
- ⊙ Content Scheduling (Publish Today, Unpublish Tomorrow)
- ⊙ Unlimited User logins
- ⊙ Unlimited Content
- ⊙ Word-like WYSIWYG Editor
- ⊙ Property Locator (Commercial/Industrial)
- ⊙ Online Payments
- ⊙ Intranet
- ⊙ Unlimited Online Fillable Forms
- ⊙ Emergency Alerts
- ⊙ Meeting Agendas/Minutes/Videos
- ⊙ Event Calendar
- ⊙ Page Versioning / Audit Trail
- ⊙ Latest News / Press Releases
- ⊙ Anti-spam controls
- ⊙ Email Harvesting Protection
- ⊙ Broken Link Finder
- ⊙ Dynamic Sitemap
- ⊙ Support for Windows, Mac, Linux
- ⊙ Video integration (YouTube, Vimeo, etc.)
- ⊙ Client owns rights to all data
- ⊙ Organization/Staff Directory
- ⊙ Frequently Asked Questions (FAQs)
- ⊙ Ordinances and Resolutions
- ⊙ Google Translate
- ⊙ Share This Button (Facebook/Twitter)
- ⊙ Secure Pages / SSL
- ⊙ Printer Friendly Pages
- ⊙ RSS Feeds Inbound/Outbound
- ⊙ Business Director
- ⊙ Email Subscriptions / Notifications
- ⊙ Parks and Trails Directory, Projects Directory

Options

- Specialty sub-site graphic designs
- Design refresh every 4 years
- Custom development

Meeting and Agenda Management Features (Optional)

Base Features

- ★ Unlimited Meetings
- ★ Unlimited Meeting Agenda Templates
- ★ Unlimited Users
- ★ Create Meetings
- ★ Submit/Add Agenda Items
- ★ Attach agenda item files
- ★ Create Agendas
- ★ Create Agenda Packets
- ★ Approve Agenda Items with Workflow
- ★ Create Meeting Minutes
- ★ Automatically Publishing to the Web – Agenda, Agenda Packet, Minutes
- ★ Voting/Roll Call
- ★ Integration with Municode Web website calendar
- ★ Self-service video time stamping – you can add timestamps of your meeting agenda items to your YouTube meeting videos
- ★ 99.95% up-time guarantee, telephone support 8AM-8PM Eastern
- ★ Email support with one-hour response time during working hours
- ★ Emergency 24x7 support
- ★ Up to 3 hours' webinar refresher trainings per year

Optional Features

- Hands-Free YouTube Video Time Stamping
- On-site visits/consultation

Our Response to your specific RFP Requirements

1. Scheduling of Content

You can automatically schedule the publishing and un-publishing of content by date.

2. Content Approval Workflow

We offer multiple options for approval workflow based on your specific needs. Our traditional setup is to empower staff to publish content restricted to their specific department(s). We also offer the ability to have an electronic approval workflow where content updates require administrative approval prior to being published.

3. CMS Look and Feel (GUI)

Our CMS is completely browser-based with a modern user interface.

4. WYSIWYG Editor

Yes, our solution includes a WYSIWYG editor that is customizable by role to maintain a uniform style guide throughout the site that is controlled via a universal stylesheet. For example, staff cannot create pages with custom fonts and colors – they are restricted to the universal styles as defined in the cascading stylesheets.

5. CMS Infrastructure Design (SQL, Front end, Server(s), network, etc.)

Our solution is built upon the Drupal Content Management System and hosted in a LAMP environment (Linux, Apache, MySQL, PHP).

6. Spell checker

Yes.

7. Document and image management

Yes, our CMS includes an advanced solution for managing and organizing media, including files and images. It is architected specifically for local government agencies to maintain an archive of all page, image, and document changes to comply with public record and FOIA requirements.

8. Publishing workflow

Yes, please see our answer to requirement #2.

9. Audit Trail

Our CMS provides page-level versioning to allow a page to be reverted to any previous version. This solution provides a complete audit history of each page update (date/time, user) and the ability to view the pages at each date/timestamp. You can also revert to any previous version of a page. The version control record occurs at the page-level and maintains document versions as documents are updated/deleted within a page.

For site-level rollback, we provide this service as part of our standard hosting and support agreement. We save daily, weekly, monthly, and annual backups.

10. Page Template Options

Our solution allows for multiple page template formats. We look forward to providing a demonstration

11. Active link verification

Our solution includes a broken link finder to verify the correctness of both internal and external links within your site.

12. Preview pages

Yes.

13. Permission-based content authoring

Our solution is configured with granular role-based permissions and each user is required to login with a unique userid and password. We also offer a two-factor authentication option using Google Authenticate.

- All staff create and edit content using the same CMS – regardless of microsite / specialty site
- Our solution includes fine-grained role-based permissions for content authoring as well as webmaster administrative controls.
- Site administrators can manage all staff roles / permissions from one common interface and restrict content authoring based on microsite
- Each microsite (department/board/committee) can control its own homepage, its own sub-menu, sub-calendar, contact info, etc. The header and global navigation will stay intact on every page top ensure a seamless user experience, but the main content area will be customizable.
- Our editing solution is among the most user-friendly in the industry, and we lock down the style options that a typical staff member can modify to provide a consistent, template-based page display.
- We provide two options for pages – standard pages and custom pages. Standard pages are template-driven to ensure a consistent look across all pages. Staff only receive the ability to create standard pages by default.
- We also offer an “Advanced Editor” role that allows users with that role to create custom HTML pages.

14. Future dating of publishing and expiring content

Yes, this feature is included.

15. Expired content archival and retrieval

Yes. We provide a report that allows you to view expired/archived content and export that report to excel. You can also easily re-publish a previously archived page.

16. Interactive charts and graphs (Big Data)

Our solution does not include a Big Data component.

17. CMS is scalable and allows for future growth

Yes. We have helped clients as large as 450,000 in population launch sites. It will be able to scale as your needs grow over time.

18. Easy to use by non-technical staff

We are consistently selected over our competitors' products due to the ease-of-use of our system by non-technical staff.

19. Custom URLs / Simple URLs

Yes, you can create an unlimited number of custom or short URLs for a page.

20. Citizen Requests / Actions (garage sale permits, report code violations, etc.)

We have two solutions that will allow you to meet this requirement – our Citizen 311 feature and/or our online fillable form tool.

CMS Design Components and Tools (Appendix B Section B)

Our response to your specific requirements are listed below.

1. Mobile First “Responsive Design”

Yes!

2. Single Site Design

Yes, you will have a single-site design using responsive design techniques. You will not need a separate mobile site design.

3. Open source CMS Solution or Proprietary CMS

Open Source

4. Open Source Experience and Platforms

We use Drupal. We are the Drupal experts for local government agencies. We also have experience with CiviCRM.

5. Flexibility in page layout and navigation

We provide several template-based options for configuring the layout of a web page. In addition, we offer an ‘advanced editor’ role of times when you need complete control of the page design using custom HTML and CSS.

6. UI/UX Manager Experience

Yes, we have deep UI/UX experience. Dave Fels, your proposed project lead, has been certified in User Experience by the Nielsen Norman Group.

7. Data Migration Tools

We use several tools for the import/export of data. We also provide a JSON-based web services API for the two-way read/write/update of meetings and community events.

8. Social Media Integration

We offer several ways to integrate social media. We will go over your specific requirements to recommend the best way to integrate social media into your design.

9. Full Site Search

Our Drupal-based solution includes a powerful search engine that is among the best in the industry. We also provide an enhanced search capability at no extra charge which allows for:

- Indexing of file attachments (content of PDFs, Office documents, agendas, minutes, etc.)
- Filtering search results by date
- Filtering search results by department/committee
- “Unified Search Integration” with your Online Code of Ordinances
- “Unified Search integration” with our optional Meeting and Agenda Management solution

10. Security Overview

Our solution is quite secure, and we take cyber security seriously. Your website will be secure from multiple perspectives:

Data Center - we host your website in a high-availability, secure data center with a high-availability network architecture.

Your website is maintained using firewalls, load balancers, multiple web application servers, and a database server. We apply security updates to the entire web server stack on a regular basis.

Data transmission - We guarantee up to 1 Terabyte of data transfer per month.

Web CMS software security - Your website is built on Drupal software that has the confidence of millions of websites in both the private sector and public sector, including whitehouse.gov, the City of Boston and the City of Los Angeles. Several built-in security mechanisms are in place to prevent cross-site scripting attacks (XSS) and Cross-site Request Forgeries (CSRF). As part of our hosting and support services, we apply security updates to your Drupal-based CMS whenever updates are posted.

Web transmission security - your website will be secured with SSL to encrypt transmission of data. By default, we SSL encrypt every page on your site to maximize security. We provide the SSL certificate at no additional charge.

User authentication security - our solution is configured with granular role-based permissions, and each user is required to login with a unique userid and password. We also offer a two-factor authentication option using Google Authenticate if that should be something you are interested in pursuing.

Data Backup - We back up your data in multiple time zones. We backup daily, weekly, monthly, and up to 7 years of annual data backups

CMS Editing Roles/Permissions - Our solution includes fine-grained role-based permissions for content authoring as well as webmaster administrative controls. Our editing solution is among the most user-friendly in the industry, and we lock down the style options that a typical staff member can modify to provide a consistent, template-based page display. We provide two options for pages – standard pages and custom pages. Standard pages are template-driven to ensure a consistent look across all pages. Staff only receive the ability to create standard pages by default. We also offer an “Advanced Editor” role that allows users with that role to create custom HTML pages.

11. Workflow concepts / capabilities

Our Drupal-based solution has a built-in workflow engine that allows us to build custom workflows tailored to your specific business processes. The rules engine includes the ability to send email notifications and to update content. We are experts in using this workflow engine and can provide custom quotes for specific workflows you wish to enable.

12. Meets ADA Requirements

We take accessibility, the ADA, and Section 508 very seriously. Our solution includes several built-in 508/ADA compliance features such as hidden links to tab to the main content area and requiring alt text on images. In addition, we ensure your website passes WCAG 2.0 (Level AA) as part of our testing process.

13. Design Recommendations multiple domains

We recommend that you manage both sites within one CMS yet still allow for separate domains and a separately branded ‘specialty sub-site’ design for the Convention and Visitor’s Bureau website. We have taken this approach with multiple customers, and it has worked out very well.

14. On premise and cloud hosting solutions

We recommend that you leverage our hosting service, as it allows us to more rapidly respond to security threats and/or performance issues should they occur.

15. Site hosting

We provide first-class hosting services in a high-availability, secure data center. Our solution is quite secure, and we take cyber security seriously. Your website will be secure from multiple perspectives:

Data Center

We host your website in a secure data center with a high-availability network architecture. Your website is maintained using firewalls, load balancers, multiple web application servers, and a database server with master-master replication. We apply security updates to the entire web server stack on a regular basis.

Data transmission

We guarantee up to 1 Terabyte of data transfer per month.

Redundant high-availability failover (optional):

We have the capability of providing premium hosting service levels by offering a mirrored copy of your site on a separate infrastructure and time zone. We would need to talk through the required service levels and bandwidth to provide pricing for this item.

Web CMS software security

We apply security updates to your Drupal-based CMS whenever updates are posted. Your website is built on Drupal software that has the confidence of millions of websites in both the private sector and public sector, including whitehouse.gov, the City of Boston and the City of Los Angeles. Several built-in security mechanisms are in place to prevent cross-site scripting attacks.

Web transmission security

Your website will be secured with SSL to encrypt transmission of data. We will SSL-enable every page on your website for maximum security.

User authentication security

Our solution is configured with granular role-based permissions, and each user is required to login with a unique user id and password. We also offer a two-factor authentication option using Google Authenticate if that should be something you are interested in pursuing.

Data Backup

We back up your data in multiple time zones. We backup daily, weekly, monthly, and up to 7 years of annual data backups.

Guaranteed Uptime

Municode will guarantee web server uptime of 99.95%. In the event this service level is not met within a given month, you will receive a credit for that month's service.

Maintenance and Customer Support

🔥 24x7 Customer support:

We will provide you contact numbers to reach us 24x7x365 for catastrophic site issues. We will also be available from Monday to Friday 8AM-8PM EST via email and phone to handle routine website operation questions from staff.

🔒 Security upgrades:

Municode will apply security upgrades to your solution's core and contributed modules as they are published by drupal.org ensuring that your website stays secure. Municode will perform security upgrades and other web server and website optimizations during off-hours, typically between the hours of 12-3AM PST, if such work requires taking the website off-line. We will provide at least 14 days' notice for any non-emergency maintenance that requires down-time.

♥ Site Monitoring and Site Recovery:

Municode will install auto-monitoring software routines that continually monitor website performance and instantly alert us when problems occur. We will act as soon as possible and no later than two hours after problems are detected.

★ Free feature upgrades:

As we update our base Municode features, you receive those upgrades for FREE.

Web (Appendix B Section C)

Our response to your RFP requirements are listed below.

1. “New Look and Feel” Designs

We will go through a detailed set of design workshops with Leavenworth to better understand your specific needs and ensures that our recommended design fits those needs as well as the needs of your Convention and Visitor’s Bureau. For that reason, we do not feel it is appropriate at this time to speculate on the best design choice for Leavenworth. We would like to pint you to two recent site launches that represent the quality of our work:

No-scroll design option: <https://www.lafayettecountywi.org/>

Scrolling design option: <https://www.corvallisoregon.gov/>

2. Emphasis should support the City’s branding

Yes, our designs will definitely support your specific branding, and we go over this in detail during the design process. This is another reason why we hesitated from creating a design concept now without truly understanding your current brand.

3. ADA Compliance components – User Experience and 508/ADA compliance

See answer to B 12.

4. Analytics Features

Your site will be integrated with Google Analytics.

5. Embedded view / URL

We have several options and formats for embedding content within a page – including internal content pages or external sites/pages.

6. Call or Query Data elements that can render changing data

Our solution is database-driven and can certainly be configured or customized to display changing data.

7. Dynamic Data setup and how to address with Cloud

We typically handle these situations through custom JSON-based web services.

8. Full integration with Leavenworth web applications

As a base offering, we allow for connecting with external systems via direct links, embed codes, or iframes. We can embed RSS feeds from external systems into your site and create outbound RSS feeds of your website content for use by external systems.

We can provide quotes for more advanced API integrations with specific systems. We would need to discuss those requirements in more detail to provide custom quotes.

Exceptions and Variances

We do not have any notable exceptions or variances to your RFP requirements.

Pricing

	One-time	Annual
<u>Website Project Implementation</u>	\$30,000	
<ul style="list-style-type: none"> • Fully functional Municode CMS with all base features • Responsive mobile-friendly website with custom City design + specialty sub-site design for Convention & Visitors Bureau • Content migration; up to 1500 pages and 10 years meetings • Training: on-site, web teleconference, video, user guides • On-site visits: 2 (1-day design, 2 days on-site training) 		
<u>Website Hosting, Maintenance, and Support</u>		\$6,000
<ul style="list-style-type: none"> • 200GB disk space, 1 terabyte data transfer per month • 99.95% up-time, telephone support 8AM-8PM Eastern • Email support - 1-hour response time during working hours • Emergency 24x7 support • Up to 3 hours' webinar refresher trainings per year 		
Total	\$30,000	\$6,000

Additional Website Options

- Meeting and Agenda Management (Municode Meetings) \$5,600 per year
- Site graphic redesign every 4th year \$600 per year (per design)
- Additional on-site visits (training, consultation, etc.) \$1500 day 1, \$1000 per day (days 2+)
- Custom Feature Development \$125 per hour or fixed bid quote

Payment Schedule

- Year 1
 - Sign contract – 50% of project costs \$15,000
 - Implement design and features – 50% project costs \$15,000
 - Conduct training (site moved to production / annual support begins) \$6,000
 - Total \$36,000**
- Years 2-5
 - \$6,000 per year
- Annual hosting and support increases in years 6+ according to the prevailing consumer price index (CPI)
- Payment schedule will be adjusted accordingly based on selected optional features

SERVICES AGREEMENT

This agreement ("AGREEMENT") is entered between the city of Leavenworth, Kansas ("CLIENT") and Municipal Code Corporation ("CONSULTANT").

1. Term of AGREEMENT. This AGREEMENT shall commence effective the date signed by the CLIENT. It shall automatically renew annually. This AGREEMENT shall terminate upon the CLIENT's providing CONSULTANT with sixty (60) days' advance written notice

2. Compensation. It is understood and agreed by and between the parties hereto, that the CLIENT shall pay the CONSULTANT for services based on the payment schedule provided as set forth in the section marked "Payment Schedule". Payment will be made to CONSULTANT within thirty (30) days of the receipt of approved invoices for services rendered.

3. Scope of Services. CONSULTANT's services under this AGREEMENT shall consist of services as detailed in the attached proposal including appendices ("SERVICES"). SERVICES may be amended or modified upon the mutual written AGREEMENT of the parties.

4. Integration. This AGREEMENT, along with the SERVICES to be performed contain the entire agreement between and among the parties, integrate all the terms and conditions mentioned herein or incidental hereto, and supersede all prior written or oral discussions or agreements between the parties or their predecessors-in-interest with respect to all or any part of the subject matter hereof.

5. Warranty. CONSULTANT warrants that any services provided hereunder will be performed in a professional and workmanlike manner and the functionality of the services will not be materially decreased during the term.

6. Liability. CONSULTANT's total liability arising out of any acts, omissions, errors, events, or default of CONSULTANT and/or any of its employees or contractors shall be limited by the provisions of the AGREEMENT and further limited to a maximum amount equal to the fees received by CONSULTANT from CLIENT under this AGREEMENT.

7. Termination. This AGREEMENT shall terminate upon the CLIENT's providing CONSULTANT with sixty (60) days' advance written notice. In the event the AGREEMENT is terminated by the CLIENT's issuance of said written notice of intent to terminate, the CONSULTANT shall pay CLIENT a pro-rated refund of any prepaid service fees (for the period from the date of the termination through to the end of the term). If, however, CONSULTANT has substantially or materially breached the standards and terms of this AGREEMENT, the CLIENT shall have any remedy or right of set-off available at law and equity.

8. Independent Contractor. CONSULTANT is an independent contractor. Notwithstanding any provision appearing in this AGREEMENT, all personnel assigned by CONSULTANT to perform services under the terms of this AGREEMENT shall be employees or agents of CONSULTANT for all purposes. CONSULTANT shall make no representation that it is the employee of the CLIENT for any purposes.

9. Confidentiality. (a) Confidential Information. For purposes of this AGREEMENT, the term "Confidential Information" means all information that is not generally known by the public and that: is obtained by CONSULTANT from CLIENT, or that is learned, discovered, developed, conceived, originated, or prepared by CONSULTANT during the process of performing this AGREEMENT, and relates directly to the business or assets of CLIENT. The term "Confidential Information" shall include, but shall not be limited to: inventions, discoveries, trade secrets, and know-how; computer software code, designs, routines, algorithms, and structures; product information; research and development information; lists

of clients and other information relating thereto; financial data and information; business plans and processes; and any other information of CLIENT that CLIENT informs CONSULTANT, or that CONSULTANT should know by virtue of its position, is to be kept confidential.

(b) **Obligation of Confidentiality.** During the term of this AGREEMENT, and always thereafter, CONSULTANT agrees that it will not disclose to others, use for its own benefit or for the benefit of anyone other than CLIENT, or otherwise appropriate or copy, any Confidential Information except as required in the performance of its obligations to CLIENT hereunder. The obligations of CONSULTANT under this paragraph shall not apply to any information that becomes public knowledge through no fault of CONSULTANT.

10. Assignment. Neither party may assign or subcontract its rights or obligations under this AGREEMENT without prior written consent of the other party, which shall not be unreasonably withheld. Notwithstanding the foregoing, either party may assign this AGREEMENT in its entirety, without consent of the other party; in connection with a merger, acquisition, corporate reorganization, or sale of its assets.

11. Cooperative Purchasing. CONSULTANT and CLIENT agree that other public agencies may purchase goods and services under this solicitation or contract at their own cost and without CONSULTANT or CLIENT incurring any financial or legal liability for such purchases.

12. Governing Law. This AGREEMENT shall be governed and construed in accordance with the laws of the State of Kansas without resort to any jurisdiction's conflicts of law, rules or doctrines.

Submitted by:

Municipal Code Corporation

By: *Brian Gilday*

Title: President, Municode WEB

Accepted by:

By: _____

Title: _____

Date: _____

**POLICY REPORT
FIRST CONSIDERATION ORDINANCE
REPEAL AND REPLACE CHARTER ORDINANCE 55
TRANSIENT GUEST TAX**

AUGUST 14, 2018

Carla Williamson, CMC City Clerk

for Paul Kramer, City Manager

ISSUE:

Consider a new charter ordinance to repeal and replace Charter Ordinance 55 related to Transient Guest Tax in the City of Leavenworth.

BACKGROUND:

At the August 7, 2018 City Commission Study Session the City Commission discussed and provided a consensus to move forward with a new charter ordinance related to Transient Guest Tax.

Charter Ordinance 55 was passed and became effective May 27, 2015. The primary purpose was to allow the City to collect its own Transient Guest Tax, rather than the tax being collected by the state and remitted to the City. When Charter Ordinance 55 was passed the City did not alter or expand upon the state statute as to the authorized use of Transient Guest Tax.

The City Commission has expressed interest in the clarification and expanded authorization to expend transient guest tax fees collected. The attached proposed draft charter ordinance, section "v" outlines the new language.

Section 5(c) of Article 12 of the Constitution of the State of Kansas allows cities to exempt or "charter out" of certain state statutes. Any changes to an existing charter ordinance requires that the charter ordinance is repealed and replaced by a new charter ordinance. Below is an extract from the "City Clerk's Manual" published by the League of Kansas Municipalities that explains the use of a charter ordinance as allowed under the Constitution of the State of Kansas.

CHARTER ORDINANCES—WHEN USED. A charter ordinance may be used when (1) there is an applicable state enactment that contains provisions in conflict with the provisions of the proposed local law; (2) the state law does not apply uniformly to all cities; and (3) the state law does not deal with one of those subjects reserved to the legislature by the Home Rule Amendment. If these conditions are met, a charter ordinance may be used to exempt the city from the whole, or any part, of the state enactment. The effect of such an exemption is to repeal the state law as it applies to the city using the charter ordinance. There is no longer a conflict between the charter ordinance and the state law because the state law no longer applies to the city following the passage of the charter ordinance.

In exempting a city from a state enactment, the charter ordinance may provide additional provisions or substitute provisions relating to the state law. The effect is to indirectly amend the state law with respect to that city. If substitute provisions are included in the charter ordinance, then such provisions may only be altered by the passage of another charter ordinance.

The passage of a charter ordinance also requires the following:

- That the charter ordinance be passed a vote of 2/3 of the governing body rather than a simple majority.
- After passed by the governing body the charter ordinance must be published once each week for two consecutive weeks in the official city newspaper.
- A 60-day waiting period is required after publication to allow time for the public to petition for a referendum on the matter. If no is filed during this time, then the charter ordinance become effective on the 61st day.
- A petition is sufficient if 10% of the number of electors who voted in the last regular city election sign. If a sufficient petition is filed during the 60-day period, an election is held and the charter ordinance becomes effective only if a majority of the electors vote in favor of it. An election, if called, must be called within 30 days after the filing of the petition and must be held within 90 days of the filing of the filing of the petition. The governing body has the option of deciding not to pursue the matter and the charter ordinance may be allowed to die. When the governing body calls an election voluntarily, or upon petition, the election ordinance is published once each week for three consecutive weeks in the official city newspaper. The county election officer (county clerk or election commissioner) conducts the election the same as any other city election. The city clerk has only the duties he or she normally would have in a city election.
- The City Clerk must send a copy of all charter ordinances to the Secretary of State's office after the 61st day or approval by election.

ACTION:

Consensus by the Governing Body to place on first consideration.

ATTACHMENTS:

- Draft Charter Ordinance

CHARTER ORDINANCE NO. _____

A CHARTER ORDINANCE OF THE CITY OF LEAVENWORTH, KANSAS, RELATING TO TRANSIENT GUEST TAX LEVY, EXEMPTING THE CITY FROM THE PROVISIONS OF K.S.A. 12-1696 THROUGH 12-1698a, INCLUSIVE, PROVIDING FOR ADDITIONAL AND SUBSTITUTE PROVISIONS ON THE SAME SUBJECT, AND REPEALING CHARTER ORDINANCE NO. 55.

WHEREAS, the City of Leavenworth, Kansas has heretofore adopted Charter Ordinance No. 55 pursuant to the provisions of Section 5(c) of Article 12 of the Constitution of the State of Kansas exempting itself and making inapplicable to it provisions of K.S.A. 12-1697 to 12-1698a and providing substitute provisions on the same subject; and

WHEREAS, Section 5(c)(4) of Article 12 of the Constitution of the State of Kansas provides that a Charter Ordinance may be repealed or amended by charter ordinance.

NOW, THEREFORE, BE IT ORDAINED BY THE GOVERNING BODY OF THE CITY OF LEAVENWORTH, KANSAS:

SECTION 1. That pursuant to the provisions of Section 5(c) of Article Twelve (12) of the Constitution of the State of Kansas, the City of Leavenworth, Kansas, hereby exempts itself from the provisions of K.S.A. 12-1696 through 12-1698a, inclusive, and adopts the following additional and substitute provisions:

- a. As used in this Charter Ordinance, the following words and phrases shall have the meanings respectively ascribed to them herein:
 - i. "Person" means an individual, firm, partnership, corporation, joint venture or other association of persons;
 - ii. "Hotel, motel or tourist court" means any structure or building which contains rooms furnished for the purposes of providing lodging, which may or may not also provide meals, entertainment or various other personal services to transient guests, and which is kept, used, maintained, advertised or held out to the public as a place where sleeping accommodations are sought for pay or compensation by transient or permanent guests and having more than two bedrooms furnished for the accommodation of such guests. For purposes of this Charter Ordinance, the terms shall also mean any lodging establishment (as such term is defined in K.S.A. 36-501, as amended), any hotel, lodging house, boarding house, or resort (as such terms are used in City Code Sec. 54-304 *et seq.*, as amended), and any short-term rental (including but not limited to so-called AirBNBs, VRBOs, or similar rental arrangements, as may be further defined by the City from time to time). The terms shall not include group homes (as defined by K.S.A. 12-736, as amended).

- iii. "Transient guest" means a person who occupies a room in a hotel, motel or tourist court for not more than 28 consecutive days;
- iv. "Business" means any person engaged in the business of renting, leasing or letting living quarters, sleeping accommodations, rooms or a part thereof in connection with any motel, hotel or tourist court;
- v. "Economic development and tourism promotion" means:
 - 1. Activities to attract visitors into the community through marketing efforts, including advertising, directed to at least one of the five basic convention and tourism market segments consisting of group tours, pleasure travelers, association meetings and conventions, trade shows and corporate meetings and travel;
 - 2. support of those activities and organizations which encourage increased lodging facility occupancy;
 - 3. economic development and related expenditures as may be determined by the governing body, including but not limited to:
 - A. Contracting with one or more agencies, organizations, individuals or groups to promote conventions and tourism for the City, and/or to promote, pursue, and manage the City's economic development activities including securing and retaining business and industry opportunities for the City;
 - B. Operating, maintaining, expanding and developing of City facilities and public areas connected with conventions or tourism;
 - C. Making payments for principal or interest for bonds issued to construct convention, community or civic centers, parks, recreational or other public facilities or public amenities that may be used in connection with conventions or tourism basis as it relates to its use for conventions, tourism and the attraction and retention of business and industry;
 - D. Defraying the cost of providing municipal services to festivals, convention and tourism functions, such as but not limited to Finance, Legal, Police, Fire, Municipal Services and Parks and Recreation Department personnel utilized for festivals, conventions, tourism and the attraction of business and industry;
 - E. Creating innovative projects and activities that relate to the promotion of conventions and tourism;

- F. activities to attract the location or relocation of industrial or commercial enterprises into the community through marketing efforts, including advertising and incentives;
 - G. activities designed to encourage retention and expansion of existing industrial or commercial enterprises in the community;
 - H. Promoting the general economic welfare of the City, including the attraction and retention of business and industry.
- vi. "Accommodations broker" means any business which maintains an inventory of two or more rooms in one or more locations which are offered for pay to a person or persons for not more than 28 consecutive days.
- b. In order to provide revenues to promote tourism and conventions, the governing body of the City of Leavenworth, Kansas (City) is hereby authorized to levy a transient guest tax at not to exceed the rate of ten percent (10%) upon the gross receipts derived from or paid directly or through an accommodations broker by transient guests for sleeping accommodations, exclusive of charges for incidental services or facilities, in any hotel, motel or tourist court. The percentage of such tax shall be determined by the City governing body and shall be specified in the resolution authorizing the same.
 - c. Any transient guest tax levied pursuant to this section shall be based on the gross rental receipts collected by any business or accommodations broker.
 - d. The transient guest taxes levied pursuant to this section shall be paid by the consumer or user to the business and it shall be the duty of each and every business to collect from the consumer or user the full amount of any such tax, or an amount equal as nearly as possible or practicable to the average equivalent thereto. Each business collecting any of the taxes levied hereunder shall be responsible for paying over the same to the City, and the City shall administer and enforce the collection of such taxes. To the extent the City timely and actually receives transient guest taxes from a third-party provider or platform (whether pursuant to a voluntary collection agreement or otherwise), then a business shall not be responsible for payment of transient guest taxes; provided, that to the extent transient guest taxes are not so timely or actually received, the business will remain responsible for payment of transient guest taxes.
 - e. The collection of any City transient guest tax authorized to be levied pursuant to this section has previously commenced as of July 1, 2015, under previous Charter Ordinance No. 55, and shall continue as of the effective date of this Charter Ordinance.
 - f. Any tax levied and collected shall become due and payable by the business monthly, on or before the 25th day of the month immediately succeeding the month

in which it is collected, with the first payment due and payable on or before the 25th day of the month specified in the resolution of the governing body which levies the tax. Each business shall make a true report to the City, on a form prescribed by the City Clerk, providing such information as may be necessary to determine the amounts to which any such tax shall apply for all gross rental receipts for the applicable month or months, which report shall be accompanied by the tax disclosed thereby. Records of gross rental receipts shall be kept separate and apart from the records of other retail sales made by a business in order to facilitate the examination of books and records as provided herein.

- g. The City Clerk or the City's authorized representative shall have the right at all reasonable times during business hours to make such examination and inspection of the books and records of a business as may be necessary to determine the accuracy of such reports.
- h. The City Clerk is hereby authorized to administer and collect any transient guest tax levied pursuant to this Charter Ordinance and to adopt such procedures as may be necessary for the efficient and effective administration and enforcement of the collection thereof. Whenever any business liable to pay any transient guest tax refuses or neglects to pay the same, the amount, including any penalty, shall be collected in the manner prescribed for the collection of the transient guest tax by the Code of Ordinances and amendments thereto. All of the taxes collected under the provisions of this Charter Ordinance shall be remitted by the City to the City Clerk in accordance with the provisions of the Code of Ordinances, and amendments thereto. Upon receipt of each such remittance, the City Clerk shall deposit the entire amount in the City treasury, and the city treasurer shall credit 2% of all taxes so collected to the City general fund to defray the expenses of the department in administration and enforcement of the collection thereof. The remainder of such taxes shall be credited to the city transient guest tax fund (also known as the convention and visitors bureau fund), which fund is hereby established.
- i. All such moneys received by the City Clerk or city treasurer from disbursements from the city transient guest tax fund shall be credited to the tourism and convention promotion fund of the city and shall only be expended for economic development and tourism promotion.
- j. Interest and penalties for failure to pay or untimely payment of transient guest tax shall be as follows:
 - i. If any taxpayer shall fail to pay the tax levied pursuant to this Charter Ordinance, and amendments thereto, there shall be added to the unpaid balance of the tax, interest at the rate per month prescribed by the Code of Ordinances, and amendments thereto, from the date the tax was due until paid.
 - ii. If any taxpayer due to negligence or intentional disregard fails to pay the tax due at the time required by or under the provisions of this Charter

Ordinance, and amendments thereto, there shall be added to the tax a penalty in an amount equal to 10% of the unpaid balance of tax due.

- iii. If any person fails to pay any tax, within sixty (60) days from the date the return or tax was due, except in the case of an extension of time granted by the city manager, there shall be added to the tax due a penalty equal to 25% of the amount of such tax.
- iv. If any taxpayer, with fraudulent intent, fails to pay any tax or make, render or sign any return, or to supply any information, within the time required by or under the provisions of this Charter Ordinance, and amendments thereto, there shall be added to the tax a penalty in an amount equal to 50% of the unpaid balance of tax due.
- v. Penalty or interest applied under the provisions of subsections j.i and j.iv shall be in addition to the penalty added under any other provisions of this section, but the provisions of subsections j.ii and j.iii shall be mutually exclusive of each other.
- vi. The failure of the taxpayer to comply with the provisions of subsections j.ii and j.iii was due to reasonable causes and not willful neglect; the city manager may waive or reduce any of the penalties upon making a record of the reasons therefor.
- vii. For serious or repeated and/or continuous violations of any of the requirements of this Charter Ordinance, or for interference with the City staff performance of duties, any license to operate or conduct business as a hotel, motel, or tourist court may be suspended and/or permanently revoked after an opportunity for a hearing before the City Commission has been provided. Prior to such action, the City Clerk shall notify the license holder in writing, stating the reasons for which the license is subject to suspension and advising that the license shall be temporarily suspended at the end of thirty (30) days following service of such a notice, unless a request for a hearing is filed with the City Clerk, by the license holder, within ten (10) days.
- viii. Hearings provided for in this Charter Ordinance shall be conducted by the City Commission at a time and place designated by the City Commission. Based upon the record of such hearing, the City Commission shall make a finding and shall sustain, modify, or rescind any official notice or order considered in the hearing. A written report of the hearing decision shall be furnished to the license holder by the City Clerk.
- ix. In addition to all other penalties provided by this section, any person who willfully fails to pay any tax imposed under this Charter Ordinance, and amendments thereto, or who makes a false or fraudulent return, or fails to keep any books or records necessary to determine the accuracy of the person's reports, or who willfully violates any regulations of the City, for

the enforcement and administration of the provisions of this Charter Ordinance, inclusive, and amendments thereto, or who aids and abets another in attempting to evade the payment of any tax imposed or who violates any other provision of this Charter Ordinance, inclusive, and amendments thereto, shall, upon conviction thereof, be fined not less than \$100.00 nor more than \$1,000.00, or be imprisoned in the city / county jail not less than one (1) month nor more than six (6) months, or be both so fined and imprisoned, in the discretion of the court.

- k. The transient guest tax authorized by this Charter Ordinance (and previous charter ordinances replaced by this Charter Ordinance) shall be levied pursuant to resolution of the City Commission authorizing the same. Current resolution B-2110 establishing rates as to transient guest taxes shall remain in effect, and is unchanged by this Charter Ordinance, and is hereby ratified.

SECTION 2: Charter Ordinance No. 55 is hereby deleted and repealed in its entirety.

SECTION 3: This Charter Ordinance shall be published once a week for two (2) consecutive weeks in the official city newspaper.

SECTION 4. This Charter Ordinance shall take effect sixty-one (61) days after its final publication, unless a sufficient petition for a referendum is filed and a referendum held on this Charter Ordinance as provided in Article 12, Section 5, Subsection (c)(3) of the Constitution of the State of Kansas, in which case this Charter Ordinance shall become effective if approved by a majority of the electors voting thereon.

PASSED AND APPROVED by the Governing Body, not less than two-thirds (2/3) of the members elect voting in favor thereof, this _____ day of _____, 2018.

Mark Preisinger, Mayor

{SEAL}

ATTEST:

Carla K. Williamson CMC, City Clerk

Published: The Leavenworth Times

First Publication Date: _____

Second Publication Date: _____

**Policy Report No. 8-2018
2018 Uniform Public Offense Code
August 14, 2018**

Prepared by:

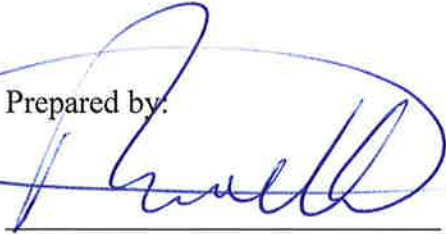

Patrick R. Kitchens, Police Chief

Approved by:

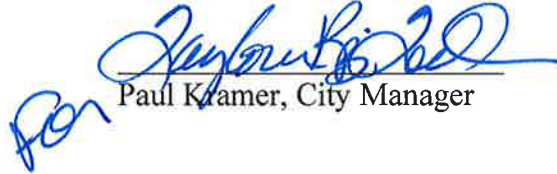

Paul Kramer, City Manager

ISSUE:

The Police Department is requesting the commission place an ordinance on first consideration that adopts the 2018 Uniform Public Offense Code for Kansas Cities for use by the City of Leavenworth.

STAFF RECOMMENDATION:

Staff recommends approval.

BACKGROUND:

Every year the League of Kansas Municipalities produces a Uniform Public Offense Code for cities in Kansas. It is designed to provide a comprehensive public offense ordinance and the City of Leavenworth has used it for many years. It does not take effect in a city until the governing body has passed and published an ordinance incorporating it as prescribed in Kansas Statutes.

The following changes are noted:

Section 3.2 – Battery Against a Law Enforcement Officer. (Amended by HB 2458)

Section 3.3 – Assault and Assault of a Law Enforcement Officer. (Amended by HB 2458)

Section 6.8 – Criminal Littering. (added by Editor)

Section 9.7 – Making an Unlawful Request for Emergency Service Assistance. (New name for the crime of Giving a False Alarm amended by HB 2581)

Section 9.9.1 – Unlawful Possession of Marijuana And Tetrahydrocannabinols. (added by Editor)

Section 9.9.2 – Unlawful Possession of Drug Paraphernalia and Simulated Controlled Substances. (Added by Editor)

Section 10.1 – Criminal Use Of Weapons. (Amended by HB 2145)

Section 10.27 – Illegal Operation of an Amusement Ride. (Amended by SB 310)

BUDGET IMPACT:

There is no budget impact.

COMMISSION ACTION:

Place an ordinance on first consideration that adopts the 2018 Uniform Public Offense Code for Kansas Cities for use by the City of Leavenworth.

(Summary Published in the Leavenworth Times on August ____, 2018)

ORDINANCE NO. _____

AN ORDINANCE AMENDING CHAPTER 70 OF THE CODE OF ORDINANCES REGULATING PUBLIC OFFENSES WITHIN THE CORPORATE LIMITS OF THE CITY OF LEAVENWORTH, KANSAS; INCORPORATING BY REFERENCE THE “UNIFORM PUBLIC OFFENSE CODE FOR KANSAS CITIES” EDITION OF 2018, WITH CERTAIN OMISSIONS AND CHANGES.

BE IT ORDAINED BY THE GOVERNING BODY OF THE CITY OF LEAVENWORTH, KANSAS:

Section 1. That the Code of Ordinances, City of Leavenworth, Kansas, Chapter 70, Offenses, Section 70-1, is hereby deleted in its entirety and amended to read as follows:

Sec. 70-1 Incorporating Uniform Public Offense Code – Incorporated by reference.

Is hereby incorporated by reference for the purpose of regulating public offenses within the corporate limits of the City of Leavenworth, Kansas, that certain code known as the *Uniform Public Offense Code for Kansas Cities*, Edition of 2018 prepared and published in book form by the League of Kansas Municipalities, Topeka, Kansas, save and except such articles, sections, parts or portions as are hereinafter omitted, deleted, notified or changed. One official copy of said *Uniform Public Offense Code* shall be marked or stamped “Official Copy as Adopted by Ordinance No. _____” with all sections or portions thereof intended to be omitted or changed clearly marked to show any such omission or change and to which shall be attached a copy of this Ordinance and filed with the City Clerk to be open to inspection and available to the public at all reasonable hours.

Section 2. That the Code of Ordinances, City of Leavenworth, Kansas, Chapter 70, Offenses, Section 70-2, is hereby deleted in its entirety and amended to read as follows:

Sec. 70-2 Same-Amendments.

Notwithstanding the foregoing, Section 5.7, Section 6.8, Section 10.6, and Section 10.23 of said *Uniform Public Offense Code* are hereby deleted in their entirety and amended to read as follows, and/or the following new sections are hereby added:

5.7 SELLING, GIVING OR FURNISHING CIGARETTES OR TOBACCO PRODUCTS TO A PERSON UNDER 21 YEARS OF AGE.

A. It shall be unlawful for any person to:

- (1) Sell, furnish or distribute to any person under the age of 21 years any cigarettes, electronic cigarettes, or tobacco products; or

- (2) Buy any cigarettes, electronic cigarettes, or tobacco products for any person under 21 years of age.
- B. It shall be a defense to a prosecution under subsection (a) of this section if:
- (1) The defendant is a licensed retail dealer, or employee thereof, or a person authorized by law to distribute samples;
 - (2) The defendant sold, furnished or distributed the cigarettes, electronic cigarettes, or tobacco products to the person under 21 years of age with reasonable cause to believe the person was of legal age to purchase or receive cigarettes, electronic cigarettes or tobacco products; and
 - (3) To purchase or receive the cigarettes, electronic cigarettes, or tobacco products, the person under 21 years of age exhibited to the defendant a driver's license, Kansas non driver's identification card or other official or apparently official document containing a photograph of the person and purporting to establish that the person was of legal age to purchase or receive cigarettes, electronic cigarettes, or tobacco products.
- C. It shall be a defense to a prosecution under subsection (a) of this section if:
- (1) The defendant engages in the lawful sale, furnishing or distribution of cigarettes, electronic cigarettes, or tobacco products by mail; and
 - (2) The defendant sold, furnished or distributed the cigarettes, electronic cigarettes, or tobacco products to the person by mail only after the person had provided to the defendant an unsworn declaration, conforming to K.S.A. 53-601, that the person was 21 or more years of age.
- D. For purposes of this section, the person who violates this section shall be the individual directly selling, furnishing or distributing the cigarettes, electronic cigarettes, or tobacco products to any person under 21 years of age, or the retail dealer who has actual knowledge of such selling, furnishing or distributing by such individual or both.
- E. *Electronic cigarette* means a device that delivers nicotine or other substances to the person inhaling from the device, including but not limited to any electronic cigarette, cigar, pipe, or hookah, including any component, part, or accessory of such a device, whether or not sold separately. Electronic cigarette shall not include any products that have been approved by the United States Food and Drug Administration for sale as a tobacco cessation product or for other therapeutic purposes where such product is marketed and sold solely for such an approved purpose.

- F. As used in this section, *sale* means any transfer of title or possession or both, exchange, barter, distribution or gift of cigarettes or tobacco products, with or without consideration.
- G. It is unlawful for any person who is a retail dealer to fail to post and maintain in a conspicuous place in the dealer's establishment the following notice: "BY LAW, CIGARETTES AND TOBACCO PRODUCTS MAY BE SOLD ONLY TO PERSONS 21 YEARS OF AGE AND OLDER." Retailer shall mean any person, firm or corporation engaged in the business of selling tobacco products, alternative nicotine products, or vapor products by personal handling to an ultimate customer or consumer.
- H. Violation of this section is a class B violation punishable by a minimum fine of \$200.

6.8 LITTERING PROHIBITED.

- A. *Definitions.* As used in this Section, the term *Litter* shall mean any rubbish, refuse, waste material, garbage, trash or debris of any kind of description, including but not limited to improperly discarded paper, metal, plastic or glass regardless of size or value.
- B. *General Littering Prohibition.* No person shall intentionally or recklessly dump, throw, place, deposit or cause to be dumped, thrown, placed, deposited or left Litter into, upon or about: 1. Any public street, highway, alley, road, right of way, park or other public place, or any lake, stream, watercourse or other body of water except by direction of a public officer or employee authorized by law to direct or permit such act; or 2. Any private property without the consent of the owner or occupant of such property. Unsolicited forms of written communication otherwise protected by the First Amendment shall be deemed as Litter upon written or oral notice from the private property owner or occupant that consent to receive such communication is withdrawn.
- C. *Littering from Motor Vehicle.* No person shall throw, place or drop litter or allow Litter to be thrown, placed or dropped from a motor vehicle onto or upon any highway, road or street. The driver of the vehicle may be cited for any such refuse, object or substance thrown, placed or dropped from the motor vehicle, unless any other person in the motor vehicle admits to or is identified as having committed the act.
- D. *Penalty.* A violation of this section shall be a Class C violation punishable by a fine not to exceed \$500.00.

10.6 AIR GUN, AIR RIFLE, BOW AND ARROW, SLINGSHOT OR BB GUN.

The unlawful operation of an Air Gun, Air Rifle, Bow and Arrow, Slingshot or BB Gun is the shooting, discharging or operating of any Air Gun, Air Rifle, Bow and Arrow, Slingshot or BB Gun, within the City, except by permit authorized by the City for deer hunting or within the confines of a building or other structure from

which to projectiles cannot escape provided that Bow and Arrow may be used in an open air archery range meeting the following requirements.

- 1) An open, flat plain with a clear and unobstructed field of distance. The maximum distance between archer and target shall be no more than 40 yards.
- 2) Target shall be situated so that any path, target, road or building is located with a 30 degree arc centered perpendicular with the shooter and target extending a minimum of 40 yards behind the target.
- 3) A target backstop be constructed which is at least 12 feet wide and 8 feet high behind each target. The backstop is to be constructed and maintained using a material, which would capture and trap arrows shot into it. The material used must not cause arrows to be deflected in another direction.
- 4) A secondary earthen backstop consisting of an earthen berm, material hill or excavated face shall be provided. The secondary backstop should be at least 30 feet wide and 16 feet high.
- 5) Operation of an archery range shall be allowed between the hours of sunrise and sunset.

Unlawful operation of an Air Gun, Air Rifle, Bow and Arrow, Slingshot or BB Gun is a class B Violation.

10.23 TRAFFICKING IN COUNTERFEIT DRUGS;

Trafficking in counterfeit drugs is intentionally manufacturing, distributing, dispensing, selling or delivering for consumption purposes, or holding or offering for sale, any counterfeit drug.

Trafficking in counterfeit drugs which have a retail value of less than \$500 is a Class A violation. (K.S.A. Supp. 65-4167)

_____ DRUG PARAPHERNALIA, SIMULATED DRUGS AND CONTROLLED SUBSTANCES; DISPLAY, SALE, POSSESSION OR DELIVERY PROHIBITED.

- A. No person shall sell or offer for sale, use or possess with intent to use:
- 1) Any simulated controlled substance;
 - 2) Any drug paraphernalia to use, store, contain, conceal, inject, ingest, inhale or otherwise introduce into the human body a controlled substance in violation of the Uniform Controlled Substances Act and any amendments thereto; or
 - 3) Any drug paraphernalia to plant, propagate, cultivate, grow or harvest less than five marijuana plants.

- B. The fact that an item has not yet been used or did not contain a controlled substance at the time of the seizure is not a defense to a charge that the item was possessed with the intention for use as drug paraphernalia.
- C. No person shall deliver, possess with intent to deliver, manufacture with intent to deliver or cause to be delivered within this City any drug paraphernalia, knowing, or under circumstances where one reasonably should know, that it will be used to use, store, contain, conceal, inject, ingest, inhale or otherwise introduce into the human body a controlled substance in violation of the Uniform Controlled Substances Act and amendments thereto.
- D. It shall be unlawful for any person to display for sale any drug paraphernalia or simulated controlled substance or simulated drug in or upon any premises.
 - 1) Nothing in this Section shall be construed to prohibit the selling, dispensing, or giving away of such items by a practitioner or pharmacist to a patient for lawful purposes.
 - 2) For the purpose of sentencing the offense is classified as a Class A misdemeanor as set forth in the Uniform Public Offense Code and the sentence shall be a definite term of confinement in the city or county jail which shall be fixed by the Court and shall not exceed one year. In addition to or instead of the confinement authorized by law a fine up to \$2,500.00 may be imposed by the Court.

Section 3. REPEAL. Sections 70-1 and 70-2 of Chapter 70, Offenses, of the Code of Ordinances of the City of Leavenworth, Kansas, in existence as of and prior to the adoption of this ordinance, are hereby repealed.

Section 4. EFFECTIVE DATE. This ordinance shall take effect and be in force from and after its publication in the official city newspaper.

PASSED and APPROVED by the Governing Body on this __th day of August, 2018.

Mark Preisinger, Mayor

{Seal}

ATTEST:

Carla K. Williamson, CMC, City Clerk

**Policy Report No. 9-2018
2018 Standard Traffic Ordinance
August 14, 2018**

Prepared by:

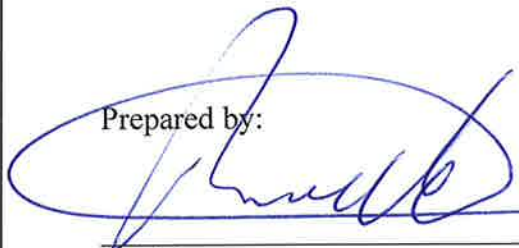

Patrick R. Kitchens, Police Chief

Approved by:



Paul Kramer, City Manager

for

ISSUE:

The Police Department is requesting the commission place an ordinance on first consideration that adopts the 2018 Standard Traffic Ordinance for Kansas Cities for use by the City of Leavenworth.

STAFF RECOMMENDATION:

Staff recommends approval.

BACKGROUND:

Every year the League of Kansas Municipalities produces a Standard Traffic Code for cities in Kansas. It is designed to provide a comprehensive traffic code and the City of Leavenworth has used it for many years. It does not take effect in a city until the governing body has passed and published an ordinance incorporating it as prescribed in Kansas Statutes.

The changes are listed below:

Section 1. Definitions

Added: Waste Collection Vehicle

Section 30. – Driving Under the Influence of Intoxicating Liquor or Drugs; Penalties (Amended by H. Sub. SB 374 and HB 2439)

Sec 30.1 – Driving a Commercial Motor Vehicle Under the Influence of Intoxicating Liquor or Drug; Penalties (Amended by H. Sub. SB 374 and HB 2439)

Section 40.1 – Passing a Stationary Waste Collection Vehicle (New section created by Sub. SB 272)

Section 112.1 – Littering from a Motor Vehicle. (Added by Editor)

Section 114.4(c) – Unlawful Operation of a Golf Cart. (Amended by Sub. SB 272)

Section 174 – Horns and Warning Devices. (New subsection (f) in response to new section 40.1)

Section 194 – Driving While License Canceled Suspended or Revoked; Penalty. (Amended by HB 2439)

BUDGET IMPACT:

There is no budget impact.

COMMISSION ACTION:

Place an ordinance on first consideration that adopts the 2018 Standard Traffic Ordinance for Kansas Cities for use by the City of Leavenworth.

(Summary Published in the Leavenworth Times on August _____, 2018)

ORDINANCE NO. _____

AN ORDINANCE AMENDING CHAPTER 110 SECTIONS 110-1 – 110-2.1 OF THE CODE OF ORDINANCES REGULATING TRAFFIC WITHIN THE CORPORATE LIMITS OF THE CITY OF LEAVENWORTH, KANSAS; INCORPORATING BY REFERENCE THE *STANDARD TRAFFIC ORDINANCE* FOR KANSAS CITIES, EDITION OF 2018, WITH CERTAIN OMISSIONS, CHANGES, AND ADDITIONS.

BE IT ORDAINED BY THE GOVERNING BODY OF THE CITY OF LEAVENWORTH, KANSAS:

Section 1. That the Code of Ordinances, City of Leavenworth, Kansas, Chapter 110, Traffic and Vehicles, Article I; In General, Section 110-1 through Section 110-2.1 shall be amended to read as follows:

Sec. 110-1 Standard Traffic Ordinance for Kansas Cities – Adopted.

There is hereby incorporated by reference for the purpose of regulating traffic within the corporate limits of the City of Leavenworth Kansas that certain standard traffic ordinance known as the *Standard Traffic Ordinance* for Kansas Cities, Edition of 2018, prepared and published in book form by the League of Kansas Municipalities, Topeka, Kansas, save and except such articles, sections, parts or portions as are hereafter omitted, deleted, modified, or changed.

Sec. 110-2 Same-Marked copies on file.

One copy of said *Standard Traffic Ordinance* shall be marked or stamped “Official Copy as Adopted by Ordinance No. _____” with all sections and portions thereof intended to be omitted or changed clearly marked to show any such omission or change and to which shall be attached a copy of this ordinance, and filed with the City Clerk to be open to inspection and available to the public at all reasonable business hours. The police department, municipal judge, and all administrative departments of the city charged with enforcement of the ordinance shall be supplied at the cost of the city, such number of official copies as such *Standard Traffic Ordinance* similarly marked, as may be deemed expedient.

Sec. 110.2.1 Same-Amendments.

Article 1. Definitions.

Section 1. Definitions be amended by adding the following definition:

Gasoline or Electric Powered Scooters means any motorized scooter not more than 51” in length, 14” in width and 30” in height, by the manufacturer’s specifications and having a seat designed to be straddled by the operator.”

Article 4. Traffic Signs, Signals and Markings be amended by adding the following:
Section 21a. Gasoline or Electric Powered Scooters. "It is unlawful to operate, or for the owner to permit the operation of, a gasoline or electric powered motorized scooter upon a street, highway, public parking lot, or public parks area."

Article 14. Miscellaneous Rules, Section 114.5 be amended, adding, as follows:
(c) "Unlawful operation of worksite utility vehicle except for public safety and city maintenance staff."

Section 2. That all ordinances found to be in conflict with the said "Standard Traffic Ordinance for Kansas Cities, Edition of 2018" be and the same are hereby repealed.

Section 3. That this ordinance shall take effect and be in force from and after its passage, approval, and publication as provided by law.

PASSED and APPROVED by the Governing Body on this __th day of August, 2018.

Mark Preisinger, Mayor

{Seal}

ATTEST:

City Clerk Carla K. Williamson, CMC

Policy Report No. 11-2018
2018 Intersection Traffic Control Device Master Index
August 14, 2018

Prepared by:



Patrick R. Kitchens, Police Chief

Approved by:

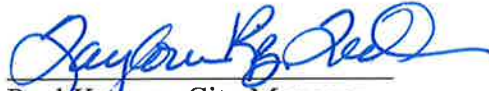
for Paul Kramer, City Manager

ISSUE:

Place an ordinance on first consideration that adopts the 2018 Intersection Traffic Control Device Master Index.

STAFF RECOMMENDATION:

Staff recommends approval.

BACKGROUND:

On an annual basis the Intersection Traffic Control Device is presented to the City Commission for approval. (Master list attached)

- The primary changes include new intersections in the Business Park on Eisenhower and the West Glenn Subdivision.

BUDGET IMPACT:

There is no budget impact.

COMMISSION ACTION:

Place an ordinance on first consideration that adopts the 2018 Intersection Traffic Control Device Master Index.

(Summary Published in the Leavenworth Times on August ____, 2018)

ORDINANCE NO. _____

AN ORDINANCE AMENDING CHAPTER 110 SEC. 110-44 OF THE CODE OF ORDINANCES REGULATING INTERSECTION TRAFFIC CONTROL DEVICES WITHIN THE CORPORATE LIMITS OF THE CITY OF LEAVENWORTH, KANSAS; INCORPORATING BY REFERENCE THE “2018 INTERSECTION TRAFFIC CONTROL DEVICE MASTER INDEX”.

BE IT ORDAINED BY THE GOVERNING BODY OF THE CITY OF LEAVENWORTH, KANSAS:

Section 1. That the Code of Ordinances, City of Leavenworth, Kansas Chapter 110, Traffic and Vehicles, Article II Local Traffic Regulations, Section 110-44 shall be amended to read as follows:

Section 110-44. Incorporating the Intersection Traffic Control Devices.

There is hereby incorporated by reference for the purpose of regulating intersection traffic control devices within the corporate limits of the City of Leavenworth, Kansas, that certain code known as the “2018 Intersection Traffic Control Device Master Index” prepared and published in book form, save and except such articles, sections, parts or portions as are hereinafter omitted, deleted, notified or changed. One copy of said *2018 Intersection Traffic Control Device Master Index* shall be marked or stamped “Official Copy as Adopted by Ordinance No. ____” with all sections and portions thereof intended to be omitted or changed clearly marked to show any such omission or change and to which shall be attached a copy of this ordinance, and filed with the City Clerk to be open to inspection and available to the public at all reasonable business hours.

Section 2. That Section 110-44 amended herein and all ordinances found to be in conflict are hereby repealed.

Section 3. This ordinance shall take effect and be in force from and after its publication in the official city newspaper as provided by law.

PASSED and APPROVED by the Governing Body on this ____th day of August, 2018.

Mark Preisinger, Mayor

ATTEST:

City Clerk Carla K. Williamson, CMC

City of Leavenworth, KS Traffic Control Device Inventory, August 9, 2018

Intersection Number	Intersection Name	Traffic Device	Direction Controlled
0002	US73 OFF RAMP/SANTA FE TRAIL	SS	WB
0007	US73 OFF RAMP/SANTA FE TRAIL	SS	EB
0007	METROPOLITAN AV/SANTA FE TRAIL	SS	SB
0008	METROPOLITAN AVE / N 20TH ST	SS	EB
0008	US73 ON RAMP/N 20TH ST	SS	NB
0009	METROPOLITIAN-PAWNEE AVE / N 20TH ST	SS	EB
0009	METROPOLITIAN-PAWNEE AVE / N 20TH ST	SS	WB
0010	N 20TH ST / DAKOTA ST	SS	EB
0010	N 20TH ST / DAKOTA ST	SS	WB
0011	DAKOTA ST / DENNY LN	SS	NB
0012	N 18TH ST / DAKOTA ST	SS	NB
0012	N 18TH ST / DAKOTA ST	SS	SB
0013	PAWNEE ST / DAKOTA ST	SS	SB
0014	N 16TH ST / DAKOTA ST (N)	SS	EB
0014	N 16TH ST / DAKOTA ST (N)	SS	SB
0015	N 16TH ST / PAWNEE ST (S)	SS	WB
0016	N 16TH ST / PAWNEE ST (N)	SS	EB
0016	N 16TH ST / PAWNEE ST (N)	SS	SB
0017	METROPOLITIAN AVE / N 16TH ST (S)	SS	EB
0018	US 73 / N 16TH ST	SS	NB
0019	METROPOLITIAN AVE / N 14TH ST	SS	NB
0020	N 14TH ST / CHEYENNE ST	SS	WB
0021	N 14TH ST / PAWNEE ST	SS	EB
0021	N 14TH ST / PAWNEE ST	SS	WB
0022	N 14TH ST / DAKOTA ST	SS	WB
0023	N 14TH ST / KIOWA ST	SS	SB
0024	N 16TH ST / DAKOTA ST (S)	SS	WB
0025	N 16TH ST / KIOWA ST	SS	SB
0027	N 13TH TERR / KIOWA ST	SS	NB
0028	METROPOLITIAN AVE / N 13TH ST	SS	NB
0029	METROPOLITIAN AVE / N 12TH ST	SS	NB
0030	METROPOLITIAN AVE / N 11TH ST	SS	NB
0031	METROPOLITIAN AV / N 10TH ST	SS	NB
0032	N 10TH ST / CHEYENNE ST	SS	EB
0032	N 10TH ST / CHEYENNE ST	SS	WB
0033	N 11TH ST / CHEYENNE ST	SS	EB
0033	N 11TH ST / CHEYENNE ST	SS	WB
0034	N 12TH ST / CHEYENNE ST	SS	EB
0034	N 12TH ST / CHEYENNE ST	SS	WB
0035	N 13TH ST / CHEYENNE ST	SS	EB

City of Leavenworth, KS Traffic Control Device Inventory, August 9, 2018

Intersection Number	Intersection Name	Traffic Device	Direction Controlled
0035	N 13TH ST / CHEYENNE ST	SS	WB
0036	N 13TH ST / PAWNEE ST	SS	EB
0036	N 13TH ST / PAWNEE ST	SS	WB
0037	N 12TH ST / PAWNEE ST	SS	EB
0037	N 12TH ST / PAWNEE ST	SS	WB
0038	N 11TH ST / PAWNEE ST	SS	EB
0038	N 11TH ST / PAWNEE ST	SS	WB
0039	N 10TH ST / PAWNEE ST	SS	EB
0039	N 10TH ST / PAWNEE ST	SS	WB
0040	N 10TH ST / DAKOTA ST	SS	EB
0040	N 10TH ST / DAKOTA ST	SS	WB
0041	N 11TH ST / DAKOTA ST	SS	EB
0041	N 11TH ST / DAKOTA ST	SS	WB
0042	N 12TH ST / DAKOTA ST	SS	EB
0042	N 12TH ST / DAKOTA ST	SS	WB
0043	N 13TH ST / DAKOTA ST	SS	EB
0043	N 13TH ST / DAKOTA ST	SS	WB
0044	N 13TH ST / KIOWA ST	SS	EB
0044	N 13TH ST / KIOWA ST	SS	WB
0045	N 12TH ST / KIOWA ST	SS	EB
0045	N 12TH ST / KIOWA ST	SS	WB
0046	N 11TH ST / KIOWA ST	SS	EB
0046	N 11TH ST / KIOWA ST	SS	WB
0047	N 10TH ST / KIOWA ST	SS	EB
0047	N 10TH ST / KIOWA ST	SS	WB
0048	N 10TH ST / KICKAPOO ST	SS	EB
0048	N 10TH ST / KICKAPOO ST	SS	WB
0049	N 11TH ST / KICKAPOO ST	SS	EB
0049	N 11TH ST / KICKAPOO ST	SS	WB
0050	N 12TH ST / KICKAPOO ST	SS	EB
0050	N 12TH ST / KICKAPOO ST	SS	WB
0051	N 13TH ST / KICKAPOO ST	SS	EB
0051	N 13TH ST / KICKAPOO ST	SS	WB
0052	N 10TH ST / OTTAWA ST	SS	EB
0052	N 10TH ST / OTTAWA ST	SS	EB
0053	N 11TH ST / OTTAWA ST	SS	NB
0053	N 11TH ST / OTTAWA ST	SS	SB
0054	N 12TH ST / OTTAWA ST	SS	SB
0054	N 12TH ST / OTTAWA ST	SS	SB
0055	N 13TH ST / OTTAWA ST	SS	NB

City of Leavenworth, KS Traffic Control Device Inventory, August 9, 2018

Intersection Number	Intersection Name	Traffic Device	Direction Controlled
0055	N 13TH ST / OTTAWA ST	SS	SB
0056	N 13TH TERR / OTTAWA ST	SS	SB
0057	N 10TH ST / POTTAWATOMIE ST	SS	EB
0057	N 10TH ST / POTTAWATOMIE ST	SS	EB
0058	N 11TH ST / POTTAWATOMIE ST	SS	EB
0058	N 11TH ST / POTTAWATOMIE ST	SS	WB
0059	N 12TH ST / POTTAWATOMIE ST	SS	EB
0059	N 12TH ST / POTTAWATOMIE ST	SS	WB
0060	N 10TH ST / OSAGE ST	SS	EB
0060	N 10TH ST / OSAGE ST	SS	WB
0061	N 10TH ST / MIAMI ST	SS	EB
0061	N 10TH ST / MIAMI ST	SS	WB
0062	N 11TH ST / OSAGE ST	SS	SB
0063	N 12TH ST / OSAGE ST	SS	SB
0064	N 13TH ST / POTTAWATOMIE ST	SS	EB
0065	N 13TH ST / OSAGE ST	SS	EB
0065	N 13TH ST / OSAGE ST	SS	WB
0068	N 16TH ST / OSAGE ST	SS	NB
0068	N 16TH ST / OSAGE ST	SS	NB
0069	N 17TH ST / OSAGE ST	SS	WB
0070	S 10TH ST / SHAWNEE ST	TL	2EB
0070	S 10TH ST / SHAWNEE ST	TL	2NB
0070	S 10TH ST / SHAWNEE ST	TL	2SB
0070	S 10TH ST / SHAWNEE ST	TL	2WB
0071	11TH ST / SHAWNEE ST	SS	NB
0071	11TH ST / SHAWNEE ST	SS	SB
0072	S 12TH ST / SHAWNEE ST	SS	NB
0073	S 13TH ST / SHAWNEE ST	SS	NB
0073	S 13TH ST / SHAWNEE ST	SS	SB
0074	N 13TH ST / SENCECA ST	SS	WB
0075	S 14TH ST / SHAWNEE ST	SS	NB
0075	S 14TH ST / SHAWNEE ST	SS	SB
0081	HOPE ST / ALLEN ST	SS	WB
0082	SHELDON ST / SHAWNEE ST	SS	SB
0083	S 15TH ST / SHAWNEE ST	SS	NB
0084	WESTERN ST / SHAWNEE ST	SS	SB
0085	ALLEN ST / SHAWNEE ST	SS	SB
0086	S 16TH ST / SHAWNEE ST	SS	NB
0087	SHAWNEE ST / LEAVENWORTH AVE	SS	NB
0088	S 17TH ST / SHAWNEE ST	SS	NB

City of Leavenworth, KS Traffic Control Device Inventory, August 9, 2018

Intersection Number	Intersection Name	Traffic Device	Direction Controlled
0088	S 17TH ST / SHAWNEE ST	SS	SB
0089	N 17TH ST / TERRY ST	SS	EB
0089	N 17TH ST / TERRY ST	SS	WB
0091	N 16TH ST / MICHAEL ST	SS	EB
0092	N 17TH ST / MIAMI ST	SS	EB
0093	N 17TH ST / MICHAEL ST	SS	WB
0094	N 17TH ST / MICHAEL ST	SS	WB
0097	N 17TH ST / OTTAWA ST	SS	NB
0098	N 18TH ST / OTTAWA ST	SS	NB
0098	N 18TH ST / OTTAWA ST	SS	SB
0099	N 19TH ST / OTTAWA ST	SS	NB
0100	N 20TH ST / OTTAWA ST	SS	EB
0100	N 20TH ST / OTTAWA ST	SS	WB
0101	N 20TH ST / POTTAWATOMIE ST	SS	WB
0103	N 18TH ST / OSAGE ST	SS	EB
0104	N 19TH ST / OSAGE ST	SS	SB
0105	N 20TH ST / OSAGE ST	SS	WB
0106	N 18TH ST / MIAMI ST	SS	EB
0107	N 18TH ST / SENECA ST	SS	EB
0107	N 18TH ST / SENECA ST	SS	WB
0108	TOPEKA AVE / SHAWNEE ST	SS	NB
0109	N 18TH ST / SHAWNEE ST	SS	EB
0109	N 18TH ST / SHAWNEE ST	SS	NB
0109	N 18TH ST / SHAWNEE ST	SS	SB
0109	N 18TH ST / SHAWNEE ST	SS	WB
0110	N 20TH ST / SHAWNEE ST	SS	EB
0110	N 20TH ST / SHAWNEE ST	SS	WB
0111	N20TH ST / SENECA ST (N)	SS	EB
0111	N20TH ST / SENECA ST (N)	SS	EB
0112	N 20TH ST / SENECA ST (S)	SS	WB
0113	N 20TH ST / MIAMI ST	SS	EB
0113	N 20TH ST / MIAMI ST	SS	WB
0117	N 21 ST / SHAWNEE ST	SS	NB
0119	N 22ND ST / OTTAWA ST	SS	NB
0125	METROPOLITIAN AV / N 9TH ST	SS	NB
0126	METROPOLITIAN AV / N 8TH ST	SS	NB
0127	METRO AV / N BROADWAY ST	SS	NB
0128	METRO AV / N 7TH ST	TL	2NB
0128	METRO AV / N 7TH ST	TL	2SB
0128	METRO AV / N 7TH ST	TL	3EB 1SB

City of Leavenworth, KS Traffic Control Device Inventory, August 9, 2018

Intersection Number	Intersection Name	Traffic Device	Direction Controlled
0128	METRO AV / N 7TH ST	TL	3WB
0129	METRO AV / N 6TH ST	SS	NB
0130	METRO AV N 5TH ST	SS	NB
0131	METRO AV / N 4TH ST	TL	3EB
0131	METRO AV / N 4TH ST	TL	3NB
0131	METRO AV / N 4TH ST	TL	3SB
0131	METRO AV / N 4TH ST	TL	3WB
0134	CHEYENNE CURV / DAKOTA ST	SS	SB
0135	N 2ND ST / CHEYENNE ST	SS	NB
0135	N 2ND ST / CHEYENNE ST	SS	SB
0136	N 2ND ST / PAWNEE LN	SS	EB
0137	N 2ND ST / DAKOTA ST	SS	EB
0137	N 2ND ST / DAKOTA ST	SS	WB
0138	N 3RD ST / DAKOTA ST	SS	EB
0138	N 3RD ST / DAKOTA ST	SS	WB
0139	N 3RD ST / PAWNEE ST	SS	EB
0140	N 3RD ST / CHEYENNE ST	SS	NB
0141	N 4TH ST / CHEYENNE ST	SS	WB
0142	N 4TH ST / PAWNEE ST	SS	EB
0142	N 4TH ST / PAWNEE ST	SS	WB
0143	N 4TH ST / DAKOTA ST	SS	WB
0144	N 4TH ST / JOHNSON ST	TL	1EB
0144	N 4TH ST / JOHNSON ST	TL	3NB 1EB
0144	N 4TH ST / JOHNSON ST	TL	3SB
0146	N 5TH ST / DAKOTA ST	SS	EB
0147	N 5TH ST / PAWNEE ST	SS	EB
0147	N 5TH ST / PAWNEE ST	SS	WB
0148	N 5TH ST / CHEYENNE ST	SS	EB
0149	N 6TH ST / CHEYENNE ST	SS	EB
0149	N 6TH ST / CHEYENNE ST	SS	WB
0150	N 6TH ST / PAWNEE ST	SS	EB
0150	N 6TH ST / PAWNEE ST	SS	WB
0151	N 6TH ST / DAKOTA ST	SS	EB
0151	N 6TH ST / DAKOTA ST	SS	WB
0152	N 7TH ST / DAKOTA ST	SS	EB
0152	N 7TH ST / DAKOTA ST	SS	WB
0153	N 7TH ST / PAWNEE ST	SS	EB
0153	N 7TH ST / PAWNEE ST	SS	WB
0154	N 7TH ST / CHEYENNE ST	SS	EB
0154	N 7TH ST / CHEYENNE ST	SS	WB

City of Leavenworth, KS Traffic Control Device Inventory, August 9, 2018

Intersection Number	Intersection Name	Traffic Device	Direction Controlled
0155	N BROADWAY ST / CHEYENNE ST	SS	EB
0155	N BROADWAY ST / CHEYENNE ST	SS	WB
0156	N BROADWAY ST / PAWNEE ST	SS	EB
0156	N BROADWAY ST / PAWNEE ST	SS	WB
0157	N BROADWAY ST / DAKOTA ST	SS	EB
0157	N BROADWAY ST / DAKOTA ST	SS	WB
0158	N 8TH ST / DAKOTA ST	SS	NB
0158	N 8TH ST / DAKOTA ST	SS	SB
0159	N 8TH ST / PAWNEE ST	SS	EB
0159	N 8TH ST / PAWNEE ST	SS	WB
0160	N 8TH ST / CHEYENNE ST	SS	EB
0160	N 8TH ST / CHEYENNE ST	SS	WB
0161	N 9TH ST / CHEYENNE ST	SS	EB
0161	N 9TH ST / CHEYENNE ST	SS	WB
0162	N 9TH ST / PAWNEE ST	SS	EB
0162	N 9TH ST / PAWNEE ST	SS	WB
0163	N 9TH ST / DAKOTA ST	SS	EB
0163	N 9TH ST / DAKOTA ST	SS	WB
0164	N 9TH ST / KIOWA ST	SS	EB
0164	N 9TH ST / KIOWA ST	SS	WB
0165	N 9TH ST / KICKAPOO ST	SS	SB
0166	N 8TH ST / KICKAPOO ST	SS	NB
0166	N 8TH ST / KICKAPOO ST	SS	SB
0167	N 8TH ST / KIOWA ST	SS	EB
0167	N 8TH ST / KIOWA ST	SS	WB
0168	N BROADWAY ST / KIOWA ST	SS	EB
0168	N BROADWAY ST / KIOWA ST	SS	WB
0169	N BROADWAY ST/KICKAPOO ST	SS	EB
0169	N BROADWAY ST/KICKAPOO ST	SS	WB
0170	N 7TH ST / KICKAPOO ST	SS	EB
0170	N 7TH ST / KICKAPOO ST	SS	WB
0171	N 7TH ST / KIOWA ST	SS	EB
0171	N 7TH ST / KIOWA ST	SS	WB
0172	N 6TH ST / KIOWA ST	SS	EB
0172	N 6TH ST / KIOWA ST	SS	WB
0173	N 6TH ST / KICKAPOO ST	SS	EB
0173	N 6TH ST / KICKAPOO ST	SS	WB
0174	N 5TH ST / KICKAPOO ST	SS	EB
0174	N 5TH ST / KICKAPOO ST	SS	WB
0175	N 5TH ST / KIOWA ST	SS	EB

City of Leavenworth, KS Traffic Control Device Inventory, August 9, 2018

Intersection Number	Intersection Name	Traffic Device	Direction Controlled
0175	N 5TH ST / KIOWA ST	SS	WB
0176	N 4TH ST / KIOWA ST	SS	EB
0176	N 4TH ST / KIOWA ST	SS	WB
0177	N 4TH ST / KICKAPOO ST	SS	EB
0177	N 4TH ST / KICKAPOO ST	SS	WB
0178	N 3RD ST / KICKAPOO ST	SS	EB
0178	N 3RD ST / KICKAPOO ST	SS	WB
0179	N 3RD ST / KIOWA ST	SS	EB
0179	N 3RD ST / KIOWA ST	SS	WB
0180	N 2ND ST / KIOWA ST	SS	EB
0181	N 2ND ST / KICKAPOO ST	SS	EB
0181	N 2ND ST / KICKAPOO ST	SS	WB
0183	N 3RD ST / MIAMI ST	SS	EB
0183	N 3RD ST / MIAMI ST	SS	WB
0185	N ESPLANDE ST/OTTAWA ST	SS	EB
0189	N ESPLANDE ST / SENECA ST	SS	EB
0190	N 2ND ST / SENECA ST	SS	EB
0190	N 2ND ST / SENECA ST	SS	WB
0191	N 2ND ST / MIAMI ST	SS	EB
0191	N 2ND ST / MIAMI ST	SS	WB
0192	N 2ND ST / OSAGE ST	SS	EB
0192	N 2ND ST / OSAGE ST	SS	WB
0193	N 2ND ST / POTTAWATOMIE ST	SS	EB
0193	N 2ND ST / POTTAWATOMIE ST	SS	WB
0194	N 2ND ST / OTTAWA ST	SS	EB
0194	N 2ND ST / OTTAWA ST	SS	WB
0195	N 3RD ST / OTTAWA ST	SS	EB
0195	N 3RD ST / OTTAWA ST	SS	WB
0196	N 3RD ST / POTTAWATOMIE ST	SS	EB
0196	N 3RD ST / POTTAWATOMIE ST	SS	WB
0197	N 3RD ST / OSAGE ST	SS	EB
0197	N 3RD ST / OSAGE ST	SS	WB
0198	N 3RD ST / MIAMI ST	SS	EB
0198	N 3RD ST / MIAMI ST	SS	WB
0200	N 4TH ST / SENECA ST	SS	EB
0200	N 4TH ST / SENECA ST	SS	WB
0202	N 4TH ST / OSAGE ST	SS	EB
0202	N 4TH ST / OSAGE ST	SS	WB
0203	N 4TH ST / POTTAWATOMIE ST	SS	EB
0203	N 4TH ST / POTTAWATOMIE ST	SS	WB

City of Leavenworth, KS Traffic Control Device Inventory, August 9, 2018

Intersection Number	Intersection Name	Traffic Device	Direction Controlled
0204	N 4TH ST / OTTAWA ST	SS	EB
0204	N 4TH ST / OTTAWA ST	SS	WB
0205	N 5TH ST / OTTAWA ST	SS	EB
0205	N 5TH ST / OTTAWA ST	SS	WB
0206	N 5TH ST / POTTAWATOMIE ST	SS	EB
0206	N 5TH ST / POTTAWATOMIE ST	SS	WB
0207	N 5TH ST / OSAGE ST	SS	EB
0207	N 5TH ST / OSAGE ST	SS	WB
0208	N 5TH ST / MIAMI ST	SS	WB
0209	N 5TH ST / SENECA ST	SS	EB
0209	N 5TH ST / SENECA ST	SS	WB
0210	N 6TH ST / SENECA ST	SS	NB
0210	N 6TH ST / SENECA ST	SS	SB
0211	N 6TH ST / MIAMI ST	SS	WB
0212	N 6TH ST / OSAGE ST	SS	EB
0213	N 6TH ST / POTTAWATOMIE ST	SS	EB
0213	N 6TH ST / POTTAWATOMIE ST	SS	WB
0214	N 6TH ST / OTTAWA ST	SS	SB
0214	N 6TH ST / OTTAWA ST	SS	WB
0215	N 7TH ST / OTTAWA ST	TL	1EB
0215	N 7TH ST / OTTAWA ST	TL	1WB
0215	N 7TH ST / OTTAWA ST	TL	1WB 1SB
0215	N 7TH ST / OTTAWA ST	TL	2NB 1EB
0216	N 7TH ST / POTTAWATOMIE ST	SS	EB
0216	N 7TH ST / POTTAWATOMIE ST	SS	WB
0217	N 7TH ST / OSAGE ST	SS	EB
0218	N 7TH ST / MIAMI ST	SS	WB
0219	N 7TH ST / SENECA ST	SS	EB
0219	N 7TH ST / SENECA ST	SS	WB
0220	S 7TH ST / SHAWNEE ST	TL	1NB 1EB
0220	S 7TH ST / SHAWNEE ST	TL	1NB 1WB
0220	S 7TH ST / SHAWNEE ST	TL	1SB 1EB
0220	S 7TH ST / SHAWNEE ST	TL	1SB 1WB
0221	S BROADWAY ST / SHAWNEE ST	TL	1EB
0221	S BROADWAY ST / SHAWNEE ST	TL	1NB
0221	S BROADWAY ST / SHAWNEE ST	TL	1SB
0221	S BROADWAY ST / SHAWNEE ST	TL	1WB
0222	N BROADWAY ST / SENECA ST	SS	EB
0222	N BROADWAY ST / SENECA ST	SS	WB
0223	N BROADWAY ST / MIAMI ST	SS	EB

City of Leavenworth, KS Traffic Control Device Inventory, August 9, 2018

Intersection Number	Intersection Name	Traffic Device	Direction Controlled
0223	N BROADWAY ST / MIAMI ST	SS	WB
0224	N BROADWAY ST / OSAGE ST	SS	EB
0224	N BROADWAY ST / OSAGE ST	SS	WB
0225	N BRDWAY / POTTAWATOMIE ST	SS	EB
0225	N BRDWAY / POTTAWATOMIE ST	SS	WB
0226	N BROADWAY ST / OTTAWA ST	SS	WB
0226	N BROADWAY ST / OTTAWA ST	SS	WB
0227	N 8TH ST / OTTAWA ST	SS	SB
0227	N 8TH ST / OTTAWA ST	SS	WB
0228	N 8TH ST / POTTAWATOMIE ST	SS	SB
0228	N 8TH ST / POTTAWATOMIE ST	SS	WB
0229	N 8TH ST / OSAGE ST	SS	NB
0229	N 8TH ST / OSAGE ST	SS	SB
0230	N 8TH ST / MIAMI ST	SS	NB
0230	N 8TH ST / MIAMI ST	SS	SB
0232	S 6TH ST / SHAWNEE ST	TL	1NB 1EB
0232	S 6TH ST / SHAWNEE ST	TL	1NB 1WB
0232	S 6TH ST / SHAWNEE ST	TL	1SB 1EB
0232	S 6TH ST / SHAWNEE ST	TL	1SB 1WB
0233	S 5TH ST / SHAWNEE ST	TL	1NB 1EB
0233	S 5TH ST / SHAWNEE ST	TL	1NB 1WB
0233	S 5TH ST / SHAWNEE ST	TL	1SB 1EB
0233	S 5TH ST / SHAWNEE ST	TL	1SB 1WB
0234	S 4TH ST / SHAWNEE ST	TL	1NB 1EB
0234	S 4TH ST / SHAWNEE ST	TL	1NB 1WB
0234	S 4TH ST / SHAWNEE ST	TL	1SB 1 EB
0234	S 4TH ST / SHAWNEE ST	TL	1SB 1WB
0235	S 3RD ST / SHAWNEE ST	SS	EB
0235	S 3RD ST / SHAWNEE ST	SS	WB
0236	S 2ND ST / SHAWNEE ST	SS	EB
0236	S 2ND ST / SHAWNEE ST	SS	WB
0237	S ESPLANDE ST / SHAWNEE ST	SS	EB
0238	S ESPLANDE ST / DELAWARE ST	SS	EB
0239	S 2ND ST / DELAWARE ST	SS	EB
0239	S 2ND ST / DELAWARE ST	SS	NB
0239	S 2ND ST / DELAWARE ST	SS	SB
0240	S 3RD ST / DELAWARE ST	SS	NB
0240	S 3RD ST / DELAWARE ST	SS	SB
0241	S 4TH ST / DELAWARE ST	TL	1NB 1EB
0241	S 4TH ST / DELAWARE ST	TL	1NB 1WB

City of Leavenworth, KS Traffic Control Device Inventory, August 9, 2018

Intersection Number	Intersection Name	Traffic Device	Direction Controlled
0241	S 4TH ST / DELAWARE ST	TL	1SB 1EB
0241	S 4TH ST / DELAWARE ST	TL	1SB 1WB
0242	S 5TH ST / DELAWARE ST	TL	1NB 1EB
0242	S 5TH ST / DELAWARE ST	TL	1NB 1WB
0242	S 5TH ST / DELAWARE ST	TL	1SB 1EB
0242	S 5TH ST / DELAWARE ST	TL	1SB 1WB
0243	N 6TH ST / DELAWARE ST	SS	EB
0243	N 6TH ST / DELAWARE ST	SS	NB
0243	N 6TH ST / DELAWARE ST	SS	SB
0244	S 7TH ST / DELAWARE ST	TL	1NB 1EB
0244	S 7TH ST / DELAWARE ST	TL	1NB 1WB
0244	S 7TH ST / DELAWARE ST	TL	1SB 1EB
0244	S 7TH ST / DELAWARE ST	TL	1SB 1WB
0245	S BROADWAY ST / DELAWARE ST	SS	EB
0245	S BROADWAY ST / DELAWARE ST	SS	WB
0246	S BROADWAY ST / CHEROKEE ST	TL	EB
0246	S BROADWAY ST / CHEROKEE ST	TL	NB
0246	S BROADWAY ST / CHEROKEE ST	TL	SB
0246	S BROADWAY ST / CHEROKEE ST	TL	WB
0247	S 7TH ST / CHEROKEE ST	TL	1NB 1EB
0247	S 7TH ST / CHEROKEE ST	TL	1NB 1WB
0247	S 7TH ST / CHEROKEE ST	TL	1SB 1EB
0247	S 7TH ST / CHEROKEE ST	TL	1SB 1WB
0248	S 6TH ST / CHEROKEE ST	TL	EB
0248	S 6TH ST / CHEROKEE ST	TL	NB
0248	S 6TH ST / CHEROKEE ST	TL	SB
0248	S 6TH ST / CHEROKEE ST	TL	WB
0249	S 5TH ST / CHEROKEE ST	TL	1NB 1EB
0249	S 5TH ST / CHEROKEE ST	TL	1NB 1WB
0249	S 5TH ST / CHEROKEE ST	TL	1SB 1EB
0249	S 5TH ST / CHEROKEE ST	TL	1SB 1WB
0250	S 4TH ST / CHEROKEE ST	TL	1NB 1EB
0250	S 4TH ST / CHEROKEE ST	TL	1NB 1WB
0250	S 4TH ST / CHEROKEE ST	TL	1SB 1EB
0250	S 4TH ST / CHEROKEE ST	TL	1SB 1WB
0251	S 3RD ST / CHEROKEE ST	SS	EB
0251	S 3RD ST / CHEROKEE ST	SS	NB
0251	S 3RD ST / CHEROKEE ST	SS	SB
0251	S 3RD ST / CHEROKEE ST	SS	WB
0252	S 2ND ST / CHEROKEE ST	SS	EB

City of Leavenworth, KS Traffic Control Device Inventory, August 9, 2018

Intersection Number	Intersection Name	Traffic Device	Direction Controlled
0252	S 2ND ST / CHEROKEE ST	SS	NB
0252	S 2ND ST / CHEROKEE ST	SS	SB
0252	S 2ND ST / CHEROKEE ST	SS	WB
0253	S ESPLANDE ST / CHEROKEE ST	SS	EB
0253	S ESPLANDE ST / CHEROKEE ST	SS	WB
0254	S ESPLANDE ST / CHOCTAW ST	SS	EB
0255	S 2ND ST / CHOCTAW ST	SS	EB
0255	S 2ND ST / CHOCTAW ST	SS	NB
0255	S 2ND ST / CHOCTAW ST	SS	SB
0255	S 2ND ST / CHOCTAW ST	SS	WB
0256	S 3RD ST / CHOCTAW ST	SS	EB
0256	S 3RD ST / CHOCTAW ST	SS	WB
0257	S 4TH ST / CHOCTAW ST	SS	EB
0257	S 4TH ST / CHOCTAW ST	SS	WB
0258	S 5TH ST / CHOCTAW ST	SS	WB
0260	S 21ST ST / HIGH ST	SS	NB
0260	S 21ST ST / HIGH ST	SS	SB
0261	S 21ST ST / CHOCTAW ST	SS	WB
0262	S 20TH ST / CHEROKEE ST	SS	WB
0263	S 20TH ST / CHOCTAW ST	SS	EB
0264	S 20TH ST / HIGH ST	SS	EB
0265	S 20TH ST / HIGH DR	SS	WB
0266	S 20TH ST / MARJORIE CIR (N)	SS	EB
0267	S 20TH ST	SS	EB
0268	HIGH DR / HIGH CT	SS	SB
0269	S 19TH ST / HIGH ST	SS	EB
0269	S 19TH ST / HIGH ST	SS	WB
0271	S 20TH ST / SPRUCE ST	TL	2EB
0271	S 20TH ST / SPRUCE ST	TL	2WB
0271	S 20TH ST / SPRUCE ST	TL	3NB
0271	S 20TH ST / SPRUCE ST	TL	3SB
0272	S 19TH ST / SPRUCE ST	SS	SB
0273	S 19TH ST / OLIVE ST	SS	WB
0274	S 18TH ST / SPRUCE ST	SS	SB
0275	S 18TH ST / OLIVE ST	SS	EB
0276	S 18TH ST / HIGH ST	SS	EB
0276	S 18TH ST / HIGH ST	SS	WB
0280	S. 18TH ST / SHERMAN AVE	SS	WB
0281	S 18TH ST CHEROKEE ST	SS	NB
0281	S 18TH ST CHEROKEE ST	SS	SB

City of Leavenworth, KS Traffic Control Device Inventory, August 9, 2018

Intersection Number	Intersection Name	Traffic Device	Direction Controlled
0282	TOPEKA AVE / CHEROKEE ST	SS	SB
0283	S 17TH ST / CHEROKEE ST	SS	SB
0284	LEAVENWORTH ST / CHEROKEE ST	SS	SB
0285	S 16TH ST / DELAWARE ST	SS	WB
0286	S 16TH ST / CHEROKEE ST	SS	NB
0286	S 16TH ST / CHEROKEE ST	SS	SB
0289	S 15TH ST / CHEROKEE ST	SS	NB
0289	S 15TH ST / CHEROKEE ST	SS	SB
0290	S 15TH ST / DELAWARE ST	SS	NB
0290	S 15TH ST / DELAWARE ST	SS	SB
0291	S 14TH ST / DELAWARE ST	SS	EB
0291	S 14TH ST / DELAWARE ST	SS	WB
0292	S 14TH ST / CHEROKEE ST	SS	NB
0292	S 14TH ST / CHEROKEE ST	SS	SB
0293	S 13TH ST / CHEROKEE ST	SS	SB
0294	S 13TH ST / DELAWARE ST	SS	EB
0294	S 13TH ST / DELAWARE ST	SS	WB
0295	S 12TH ST / DELAWARE ST	SS	EB
0295	S 12TH ST / DELAWARE ST	SS	WB
0296	S 12TH ST / CHEROKEE ST	SS	SB
0297	S 11TH ST / DELAWARE ST	SS	EB
0298	S 11TH ST / CHEROKEE ST	SS	NB
0298	S 11TH ST / CHEROKEE ST	SS	SB
0301	TERRACE RD / SHERMAN AVE	SS	EB
0303	S 15TH ST / SANDERS ST	SS	NB
0304	S 15TH ST / HIGH ST	SS	SB
0305	S 13TH ST / HIGH ST	Y	SB
0307	TERRACE RD / HIGH ST	SS	NB
0307	TERRACE RD / HIGH ST	SS	SB
0308	S 17TH TERR / SPRUCE ST	SS	NB
0309	S 17TH ST / SPRUCE ST	SS	NB
0310	S 16TH ST / SPRUCE ST	SS	SB
0311	SPRUCE ST / S 15TH ST (W)	SS	NB
0313	S 14TH ST / SPRUCE ST	SS	NB
0313	S 14TH ST / SPRUCE ST	SS	SB
0314	S 14TH ST / OLIVE ST	SS	NB
0315	TERRACE RD / SPRUCE ST	SS	SB
0316	TERRACE RD / OLIVE ST	SS	EB
0316	TERRACE RD / OLIVE ST	SS	WB
0317	NEWMAN ST / SPRUCE ST	SS	SB

City of Leavenworth, KS Traffic Control Device Inventory, August 9, 2018

Intersection Number	Intersection Name	Traffic Device	Direction Controlled
0318	NEWMAN ST / OLIVE ST	SS	NB
0318	NEWMAN ST / OLIVE ST	SS	SB
0319	NEWMAN ST / HIGH ST	SS	NB
0320	SPRUCE ST / GRAND AVE	SS	2EB
0320	SPRUCE ST / GRAND AVE	SS	2WB
0321	S 10TH ST ON RAMP / SPRUCE ST	Y	WB
0323	S 10TH ST / OLIVE ST	SS	EB
0323	S 10TH ST / OLIVE ST	SS	WB
0325	GRAND AVE / OLIVE ST	SS	EB
0325	GRAND AVE / OLIVE ST	SS	WB
0327	GRAND AVE / HIGH ST	SS	EB
0328	GRAND AVE / CHESTNUT ST	SS	WB
0329	S 10TH ST / CHESTNUT	SS	EB
0330	SPRUCE ST / 10TH AVE	TL	2EB
0330	SPRUCE ST / 10TH AVE	TL	2NB
0330	SPRUCE ST / 10TH AVE	TL	2SB
0330	SPRUCE ST / 10TH AVE	TL	2WB 1NB
0331	GRAND AVE / SANDERS ST	SS	EB
0332	GRAND ST / WALNUT ST	SS	WB
0333	S 10TH ST / WALNUT ST	SS	EB
0333	S 10TH ST / WALNUT ST	SS	WB
0334	S 10TH ST / SHERMAN AVE	SS	NBEB
0334	S 10TH ST / SHERMAN AVE	SS	SBWB
0335	GRAND AV / SHERMAN AV (S)	SS	WB
0336	GRAND AV / SHERMAN AV (N)	SS	EB
0338	GRAND ST / CHEROKEE ST	SS	NB
0339	S 10TH ST / CHEROKEE ST	SS	EB
0339	S 10TH ST / CHEROKEE ST	SS	WB
0340	S 10TH ST / DELAWARE ST	SS	WB
0342	S 9TH ST / CHEROKEE ST	SS	NB
0342	S 9TH ST / CHEROKEE ST	SS	SB
0343	RYAN ST / CHEROKEE ST	SS	SB
0345	CHEROKEE ST / CHEROKEE ST	SS	SB
0346	LAWRENCE AVE / CHEROKEE ST	SS	NB
0347	CHEROKEE ST / SHERMAN AV	SS	SB
0348	S 9TH ST / SHERMAN AV (E)	SS	SB
0349	S 9TH ST / SHERMAN AV (W)	SS	NB
0350	LAWRENCE AV / CHOCTAW ST	SS	WB
0351	LAWRENCE AVE / CHOCTAW ST	SS	EB
0352	S 9TH ST / WALNUT ST	SS	EB

City of Leavenworth, KS Traffic Control Device Inventory, August 9, 2018

Intersection Number	Intersection Name	Traffic Device	Direction Controlled
0352	S 9TH ST / WALNUT ST	SS	WB
0353	S 9TH ST / CHESTNUT ST	SS	EB
0353	S 9TH ST / CHESTNUT ST	SS	WB
0354	LAWRENCE AVE / CHESTNUT ST	SS	EB
0356	S 9TH ST / OLIVE ST	SS	EB
0356	S 9TH ST / OLIVE ST	SS	NB
0356	S 9TH ST / OLIVE ST	SS	SB
0357	10TH AVE ON RAMP / SPRUCE ST	Y	EB
0358	SPRUCE ST / S 9TH ST	SS	SB
0359	SPRUCE ST / LAWRENCE AVE	SS	SB
0360	SPRUCE ST / CENTRAL AVE	SS	NB
0361	RAILROAD AV / SPRUCE ST	SS	SB
0362	SPRUCE ST / 9TH AVE	SS	NB
0363	SPRUCE ST / COLUMBIA AVE	SS	NB
0363	SPRUCE ST / COLUMBIA AVE	SS	SB
0364	SPRUCE ST / S BROADWAY ST	TL	1NB 1EB
0364	SPRUCE ST / S BROADWAY ST	TL	1NB 1WB
0364	SPRUCE ST / S BROADWAY ST	TL	1SB 1EB
0364	SPRUCE ST / S BROADWAY ST	TL	1SB 1WB
0365	6TH AVE / SPRUCE ST (E)	SS	NB
0366	6TH AVE / SPRUCE ST (W)	SS	SB
0367	W 7TH ST / SPRUCE (E)	SS	NB
0368	W 7TH ST / SPRUCE (W)	SS	SB
0369	SPRUCE ST / S 7TH ST (W)	TL	1NB
0369	SPRUCE ST / S 7TH ST (W)	TL	1NB
0369	SPRUCE ST / S 7TH ST (W)	TL	1NB
0369	SPRUCE ST / S 7TH ST (W)	TL	1SB
0369	SPRUCE ST / S 7TH ST (W)	TL	1WB
0369	SPRUCE ST / S 7TH ST (W)	TL	2WB
0371	S BROADWAY ST / OLIVE ST	SS	WB
0372	6TH AVE / OLIVE ST	SS	NB
0372	6TH AVE / OLIVE ST	SS	SB
0373	W 7TH ST / OLIVE ST (N)	SS	EB
0374	W 7TH ST / OLIVE ST (S)	SS	WB
0376	S 7TH ST / OLIVE ST	SS	NB
0376	S 7TH ST / OLIVE ST	SS	NB
0376	S 7TH ST / OLIVE ST	SS	NB
0377	S BROADWAY ST / CHESTNUT ST	SS	WB
0378	6TH AVE / CHEST NUT ST	SS	NB
0378	6TH AVE / CHEST NUT ST	SS	SB

City of Leavenworth, KS Traffic Control Device Inventory, August 9, 2018

Intersection Number	Intersection Name	Traffic Device	Direction Controlled
0379	W 7TH ST / CHESTNUT ST (N)	SS	EB
0380	W 7TH ST / CHESTNUT ST (S)	SS	WB
0381	S 7TH ST CHESTNUT ST	SS	EB
0381	S 7TH ST CHESTNUT ST	SS	WB
0382	S 7TH ST / WALNUT ST	SS	EB
0382	S 7TH ST / WALNUT ST	SS	WB
0383	W 7TH ST / WALNUT ST (S)	SS	WB
0384	W 7TH ST / WALNUT ST (N)	SS	EB
0385	6TH AVE / WALNUT ST	SS	NB
0385	6TH AVE / WALNUT ST	SS	SB
0386	S BROAD WAY ST / WALNUT ST	SS	WB
0387	S BROADWAY ST / OAK ST	SS	WB
0388	6TH AVE / OAK ST	SS	NB
0389	W 7TH ST / OAK ST (N)	SS	EB
0390	W 7TH ST / OAK ST (S)	SS	WB
0391	S 7TH ST OAK ST	SS	EB
0391	S 7TH ST OAK ST	SS	WB
0393	S 7TH ST / SHORT ST	SS	EB
0395	S 6TH ST / SHORT ST	SS	EB
0396	S 6TH ST / OAK ST	SS	EB
0396	S 6TH ST / OAK ST	SS	WB
0397	S 5TH ST / OAK ST	SS	EB
0398	S 6TH ST / WALNUT ST	SS	EB
0398	S 6TH ST / WALNUT ST	SS	WB
0399	S 5TH ST / WALNUT ST	SS	EB
0399	S 5TH ST / WALNUT ST	SS	WB
0400	S 4TH ST / WALNUT ST	SS	EB
0400	S 4TH ST / WALNUT ST	SS	WB
0401	S 2ND ST / CHESTNUT ST	SS	EB
0402	S 3RD ST / CHEST NUT ST	SS	EB
0402	S 3RD ST / CHEST NUT ST	SS	WB
0403	S 3RD ST / MARKET ST	SS	EB
0404	S 3RD ST / WALNUT ST	SS	EB
0405	S 4TH ST / MARKET ST	SS	WB
0406	S 4TH ST / CHESTNUT ST	SS	WB
0407	S 5TH ST / CHESTNUT ST	SS	EB
0407	S 5TH ST / CHESTNUT ST	SS	WB
0408	S 6TH ST / CHESTNUT ST	SS	EB
0408	S 6TH ST / CHESTNUT ST	SS	WB
0409	S 6TH ST / OLIVE ST	SS	EB

City of Leavenworth, KS Traffic Control Device Inventory, August 9, 2018

Intersection Number	Intersection Name	Traffic Device	Direction Controlled
0409	S 6TH ST / OLIVE ST	SS	WB
0410	S 5TH ST / OLIVE ST	SS	EB
0410	S 5TH ST / OLIVE ST	SS	WB
0411	S 4TH ST / OLIVE ST	SS	EB
0411	S 4TH ST / OLIVE ST	SS	WB
0412	S 3RD ST / OLIVE ST	SS	EB
0412	S 3RD ST / OLIVE ST	SS	WB
0413	S 2ND ST / OLIVE ST	SS	EB
0413	S 2ND ST / OLIVE ST	SS	WB
0416	SPRUCE ST / S 2ND ST	SS	EB
0416	SPRUCE ST / S 2ND ST	SS	NB
0416	SPRUCE ST / S 2ND ST	SS	SB
0416	SPRUCE ST / S 2ND ST	SS	WB
0417	SPRUCE ST / S 3RD ST	SS	EB
0417	SPRUCE ST / S 3RD ST	SS	NB
0417	SPRUCE ST / S 3RD ST	SS	SB
0417	SPRUCE ST / S 3RD ST	SS	WB
0418	SPRUCE ST / S 4TH ST	TL	2EB
0418	SPRUCE ST / S 4TH ST	TL	2WB
0418	SPRUCE ST / S 4TH ST	TL	3NB
0418	SPRUCE ST / S 4TH ST	TL	3SB
0419	SPRUCE ST / S 5TH ST	TL	2EB
0419	SPRUCE ST / S 5TH ST	TL	2NB
0419	SPRUCE ST / S 5TH ST	TL	2SB
0419	SPRUCE ST / S 5TH ST	TL	2WB
0420	SPRUCE ST / 3RD AVE	SS	2EB
0421	SPRUCE ST / S 6TH ST	SS	SB
0422	SPRUCE ST / 4TH AVE	SS	NB
0423	S 22ND ST / SPRUCE ST	SS	NB
0424	S 21ST ST / SPRUCE ST	SS	NB
0430	S 20TH ST / EDGEWOOD DR	SS	WB
0433	S 20TH ST / WOODRIDGE DR	SS	WB
0436	S 20TH ST / LECOMPTON RD	SS	EB
0436	S 20TH ST / LECOMPTON RD	SS	WB
0437	S 18TH ST / LECOMPTON RD	SS	NB
0438	WESTERN ST / OHIO ST	SS	SB
0439	S 15TH ST / OHIO ST	SS	SB
0441	S 15TH ST / KANSAS ST (N)	SS	WB
0442	S 15TH ST / KANSAS ST (S)	SS	EB
0443	WESTERN ST / KANSAS ST	SS	NB

City of Leavenworth, KS Traffic Control Device Inventory, August 9, 2018

Intersection Number	Intersection Name	Traffic Device	Direction Controlled
0444	S 16TH ST / KANSAS ST (E)	SS	NB
0445	S 16TH ST / KANSAS ST (W)	SS	WB
0448	S 15TH ST / QUINCY ST	SS	NB
0449	PATTERSON ST / QUINCY ST	SS	NB
0450	S 14TH ST / QUINCY ST	SS	SB
0451	MADISON ST / QUINCY ST	SS	SB
0452	WASHINGTON ST / QUINCY ST	SS	EB
0452	WASHINGTON ST / QUINCY ST	SS	NB
0452	WASHINGTON ST / QUINCY ST	SS	SB
0452	WASHINGTON ST / QUINCY ST	SS	WB
0453	WESTWOOD DR / OHIO ST	SS	NB
0454	STONELEIGH CT / OHIO ST (W)	SS	NB
0455	STONELEIGH CT / OHIO ST (E)	SS	NB
0456	WASHINGTON ST / OHIO ST	SS	SB
0457	JACKSON ST / OHIO ST	SS	NB
0458	FRANKLIN ST / OHIO ST (W)	SS	NB
0459	FRANKLIN ST / OHIO ST (E)	SS	SB
0460	NEWMAN ST OHIO ST	SS	NB
0461	KLEMP ST / OHIO ST	SS	NB
0462	GRAND AVE / OHIO ST	SS	NB
0462	GRAND AVE / OHIO ST	SS	SB
0463	S 11TH ST / OHIO ST	SS	NB
0464	KINGMAN ST / OHIO ST	SS	SB
0465	FRANKLIN ST / KANSAS ST	SS	WB
0466	NEWMAN ST / KANSAS ST	SS	SB
0467	KLEMP ST / KANSAS ST	SS	NB
0467	KLEMP ST / KANSAS ST	SS	SB
0469	GRAND AVE / KANSAS ST	SS	EB
0469	GRAND AVE / KANSAS ST	SS	WB
0470	KINGMAN ST / KANSAS ST	SS	NB
0470	KINGMAN ST / KANSAS ST	SS	SB
0471	JACKSON ST / QUINCY ST	SS	SB
0472	FRANKLIN ST / QUINCY ST	SS	EB
0472	FRANKLIN ST / QUINCY ST	SS	WB
0473	NEWMAN ST / QUINCY ST	SS	NB
0474	KLEMP ST / QUINCY ST	SS	NB
0475	GRAND AVE / QUINCY ST	SS	EB
0475	GRAND AVE / QUINCY ST	SS	WB
0477	10TH AVE / OHIO ST	SS	EB
0478	10TH AVE / KANSAS ST	SS	EB

City of Leavenworth, KS Traffic Control Device Inventory, August 9, 2018

Intersection Number	Intersection Name	Traffic Device	Direction Controlled
0478	10TH AVE / KANSAS ST	SS	WB
0479	10TH AVE / QUINCY ST	SS	EB
0480	10TH AVE / IRONMOULDERS ST	SS	EB
0481	GRAND AVE / IRONMOULDERS ST	SS	EB
0481	GRAND AVE / IRONMOULDERS ST	SS	WB
0482	KLEMP ST / IRONMOULDERS ST	SS	SB
0483	FRANKLIN ST / IRONMOULDERS ST	SS	WB
0484	WASHINGTON ST / RANDOLPH ST	SS	WB
0485	JACKSON ST / RANDOLPH ST	SS	NB
0485	JACKSON ST / RANDOLPH ST	SS	SB
0486	FRANKLIN ST / RANDOLPH ST	SS	EB
0486	FRANKLIN ST / RANDOLPH ST	SS	WB
0487	KLEMP ST / RANDOLPH ST	SS	NB
0487	KLEMP ST / RANDOLPH ST	SS	SB
0488	GRAND AVE / RANDOLPH ST	SS	EB
0488	GRAND AVE / RANDOLPH ST	SS	WB
0489	10TH AVE / RANDOLPH ST	SS	EB
0490	10TH AVE / KENTON ST	SS	EB
0492	GRAND AVE / KENTON ST	SS	EB
0492	GRAND AVE / KENTON ST	SS	WB
0493	KLEMP ST / KENTON ST	SS	EB
0493	KLEMP ST / KENTON ST	SS	WB
0494	FRANKLIN ST / KENTON ST	SS	WB
0496	SPRUCE ST / KLEMP ST	SS	NB
0497	FRANKLIN ST / SPRUCE ST	SS	NB
0498	JACKSON ST / SPRUCE ST	SS	NB
0499	WASHINGTON ST / SPRUCE ST	SS	NB
0500	MADISON ST / SPRUCE ST	SS	NB
0505	CENTRAL AVE / RANDOLPH ST	SS	WB
0506	9TH AVE	SS	EB
0507	9TH AVE / FRANK ST	SS	WB
0508	COLUMBIA AVE / FRANK ST	SS	EB
0508	COLUMBIA AVE / FRANK ST	SS	WB
0509	S BROADWAY ST / FRANK ST	SS	EB
0509	S BROADWAY ST / FRANK ST	SS	WB
0510	6TH AVE / FRANK ST	SS	EB
0510	6TH AVE / FRANK ST	SS	WB
0511	W 7TH ST / FRANK ST	SS	EB
0512	W 7TH ST / CONGRESS ST	SS	WB
0513	5TH AVE / CONGRESS ST	SS	EB

City of Leavenworth, KS Traffic Control Device Inventory, August 9, 2018

Intersection Number	Intersection Name	Traffic Device	Direction Controlled
0513	5TH AVE / CONGRESS ST	SS	WB
0514	4TH AVE / CONGRESS ST	SS	EB
0514	4TH AVE / CONGRESS ST	SS	WB
0516	CENTRAL AVE / CHARLES ST	SS	EB
0516	CENTRAL AVE / CHARLES ST	SS	WB
0517	0517	SS	EB
0517	9TH AVE / CHARLES ST	SS	WB
0518	COLUMBIA AVE / CHARLES ST	SS	EB
0519	COLUMBIA AVE / MARSHALL ST	SS	WB
0520	S BROADWAY ST / MARSHALL ST	SS	EB
0520	S BROADWAY ST / MARSHALL ST	SS	WB
0521	6TH AVE / MARSHALL ST	SS	SB
0522	W 7TH ST / MARSHALL ST	SS	SB
0523	5TH AVE / MARSHALL ST	SS	EB
0523	5TH AVE / MARSHALL ST	SS	WB
0524	5TH AVE / MIDDLE ST	SS	WB
0525	5TH AVE SCOTT ST	SS	EB
0526	6TH AVE / SCOTT ST	SS	WB
0527	6TH AVE JAMES ST	SS	EB
0528	S BROADWAY ST / JAMES ST	SS	EB
0528	S BROADWAY ST / JAMES ST	SS	WB
0529	COLUMBIA AVE / JAMES ST	SS	EB
0529	COLUMBIA AVE / JAMES ST	SS	WB
0530	9TH AVE / JAMES ST	SS	EB
0530	9TH AVE / JAMES ST	SS	WB
0531	CENTRAL AVE / JAMES ST	SS	EB
0531	CENTRAL AVE / JAMES ST	SS	WB
0532	LAWRENCE AVE / QUINCY ST	SS	EB
0532	LAWRENCE AVE / QUINCY ST	SS	WB
0533	LAWRENCE AVE / KANSAS ST	SS	NB
0533	LAWRENCE AVE / KANSAS ST	SS	SB
0534	CENTRAL AVE / KANSAS ST	SS	EB
0534	CENTRAL AVE / KANSAS ST	SS	NB
0534	CENTRAL AVE / KANSAS ST	SS	SB
0534	CENTRAL AVE / KANSAS ST	SS	WB
0535	9TH AVE / KANSAS ST	SS	NB
0535	9TH AVE / KANSAS ST	SS	SB
0536	COLUMBIA AVE / KANSAS ST	SS	NB
0536	COLUMBIA AVE / KANSAS ST	SS	SB
0537	S BROADWAY ST / KANSAS ST	SS	EB

City of Leavenworth, KS Traffic Control Device Inventory, August 9, 2018

Intersection Number	Intersection Name	Traffic Device	Direction Controlled
0538	S BROADWAY ST / OHIO ST	SS	EB
0538	S BROADWAY ST / OHIO ST	SS	WB
0539	COLUMBIA ST / OHIO ST	SS	EB
0539	COLUMBIA ST / OHIO ST	SS	WB
0540	9TH AVE / OHIO ST	SS	EB
0540	9TH AVE / OHIO ST	SS	WB
0541	CENTRAL AVE / OHIO ST	SS	SB
0543	6TH AVE / PROSPECT ST	SS	WB
0544	5TH AVE PROSPECT ST	SS	EB
0544	5TH AVE PROSPECT ST	SS	WB
0545	4TH AVE / MARSHALL ST	SS	EB
0545	4TH AVE / MARSHALL ST	SS	WB
0546	3RD AVE / MARSHALL ST	SS	EB
0546	3RD AVE / MARSHALL ST	SS	WB
0547	3RD AVE / CONGRESS ST	SS	EB
0547	3RD AVE / CONGRESS ST	SS	WB
0548	S 5TH ST / PINE ST	SS	WB
0549	2ND AVE / CONGRESS ST	SS	EB
0550	2ND AVE / ARCH ST	SS	WB
0551	2ND AVE / MARSHALL ST	SS	EB
0552	2ND AVE / VINE ST	SS	WB
0553	2ND AVE / MIDDLE ST	SS	EB
0554	3RD AVE / MIDDLE ST	SS	NB
0554	3RD AVE / MIDDLE ST	SS	SB
0555	4TH AVE / MIDDLE ST	SS	NB
0555	4TH AVE / MIDDLE ST	SS	SB
0556	4TH AVE / PROSPECT ST	SS	NB
0556	4TH AVE / PROSPECT ST	SS	SB
0557	3RD AVE / PROSPECT ST	SS	NB
0557	3RD AVE / PROSPECT ST	SS	SB
0558	2ND AV / ELM ST	SS	WB
0559	S 6TH ST / ELM ST	SS	NB
0561	2ND AVE LINN ST	SS	WB
0562	2ND AVE / PROSPECT ST	SS	EB
0563	2ND AVE / OHIO ST	SS	EB
0564	3RD AVE / OHIO ST	SS	NB
0564	3RD AVE / OHIO ST	SS	SB
0565	4TH AVE / OHIO ST	SS	NB
0565	4TH AVE / OHIO ST	SS	SB
0566	5TH AVE / OHIO ST	SS	EB

City of Leavenworth, KS Traffic Control Device Inventory, August 9, 2018

Intersection Number	Intersection Name	Traffic Device	Direction Controlled
0566	5TH AVE / OHIO ST	SS	WB
0568	6TH AVE / OHIO ST	SS	SB
0569	10TH AVE / MICHIGAN ST	SS	EB
0569	10TH AVE / MICHIGAN ST	SS	WB
0571	10TH AVE / PENNSYLVANIA ST	TL	2EB
0571	10TH AVE / PENNSYLVANIA ST	TL	2NB
0571	10TH AVE / PENNSYLVANIA ST	TL	2SB
0571	10TH AVE / PENNSYLVANIA ST	TL	2WB
0572	LAWRENCE AVE/PENNSYLVANIA ST	SS	NB
0572	LAWRENCE AVE/PENNSYLVANIA ST	SS	SB
0573	9TH AVE / PENNSYLVANIA ST (W)	SS	NB
0574	9TH AVE / PENNSYLVANIA ST (E)	SS	SB
0575	GARLAND ST / PENNSYLVANIA ST	SS	NB
0576	S BROADWAY ST/PENNSYLVANIA ST	SS	EB
0576	S BROADWAY ST/PENNSYLVANIA ST	SS	NB
0576	S BROADWAY ST/PENNSYLVANIA ST	SS	SB
0576	S BROADWAY ST/PENNSYLVANIA ST	SS	WB
0577	W 7TH ST / PENNSYLVANIA ST	SS	SB
0578	5TH AVE / PENNSYLVANIA ST	SS	EB
0578	5TH AVE / PENNSYLVANIA ST	SS	WB
0579	4TH AVE / PENNSYLVANIA ST	SS	NB
0579	4TH AVE / PENNSYLVANIA ST	SS	SB
0580	3RD AVE / PENNSYLVANIA ST	SS	NB
0580	3RD AVE / PENNSYLVANIA ST	SS	SB
0581	2ND AVE / PENNSYLVANIA ST (S)	SS	WB
0582	2ND AVE / PENNSYLVANIA ST (N)	SS	EB
0583	2ND AVE / ISABELLE ST	SS	WB
0584	2ND AVE / MICHIGAN ST	SS	EB
0585	2ND AVE / ELIZABETH ST	SS	WB
0586	3RD AVE / MICHIGAN ST	SS	NB
0586	3RD AVE / MICHIGAN ST	SS	SB
0587	4TH AVE / MICHIGAN ST	SS	NB
0587	4TH AVE / MICHIGAN ST	SS	SB
0588	5TH AVE / MICHIGAN ST	SS	EB
0588	5TH AVE / MICHIGAN ST	SS	WB
0591	S BROADWAY ST / MICHIGAN ST	SS	EB
0591	S BROADWAY ST / MICHIGAN ST	SS	WB
0593	COLUMBIA AVE / MICHIGAN ST	SS	SB
0594	9TH AVE / MICHIGAN ST	SS	EB
0594	9TH AVE / MICHIGAN ST	SS	WB

City of Leavenworth, KS Traffic Control Device Inventory, August 9, 2018

Intersection Number	Intersection Name	Traffic Device	Direction Controlled
0595	S 5TH ST / PENNSYLVANIA ST	SS	EB
0595	S 5TH ST / PENNSYLVANIA ST	SS	WB
0596	ROSE ST / PENNSYLVANIA ST	SS	NB
0596	ROSE ST / PENNSYLVANIA ST	SS	SB
0597	S 4TH ST / PENNSYLVANIA ST	SS	EB
0598	S 5TH ST / ISABELLE ST	SS	EB
0599	S 5TH ST / ELIZABETH ST	SS	EB
0600	S 5TH ST / MAPLE ST	SS	WB
0601	S 4TH ST / MAPLE ST	SS	EB
0602	S 4TH ST / POPLAR ST	TL	WB
0602	S 4TH ST / POPLAR ST	TL	WB
0602	S 4TH ST / POPLAR ST	TL	WB
0602	S 4TH ST / POPLAR ST	TL	WB
0603	S 3RD ST / POPLAR ST	SS	SB
0604	S 2ND ST / POPLAR ST	SS	NB
0604	S 2ND ST / POPLAR ST	SS	SB
0604	S 2ND ST / POPLAR ST	SS	WB
0605	S 2ND ST / MAPLE ST	SS	EB
0606	S 3RD ST / MAPLE ST	SS	WB
0607	S 2ND ST / LINN ST	SS	EB
0608	S 3RD ST / LINN ST	SS	EB
0608	S 3RD ST / LINN ST	SS	WB
0609	S 4TH ST / LINN ST	SS	EB
0609	S 4TH ST / LINN ST	SS	WB
0610	S 5TH ST / LINN ST	SS	EB
0610	S 5TH ST / LINN ST	SS	NB
0610	S 5TH ST / LINN ST	SS	SB
0610	S 5TH ST / LINN ST	SS	WB
0611	S 5TH ST / ELM ST	SS	EB
0611	S 5TH ST / ELM ST	SS	WB
0612	S 4TH ST / ELM ST	SS	EB
0612	S 4TH ST / ELM ST	SS	WB
0613	S 3RD ST / ELM ST	SS	EB
0613	S 3RD ST / ELM ST	SS	WB
0614	S 2ND ST / ELM ST	SS	EB
0614	S 2ND ST / ELM ST	SS	WB
0616	S 5TH ST / VINE ST	SS	EB
0616	S 5TH ST / VINE ST	SS	WB
0617	S 5TH ST / ARCH ST	SS	EB
0617	S 5TH ST / ARCH ST	SS	WB

City of Leavenworth, KS Traffic Control Device Inventory, August 9, 2018

Intersection Number	Intersection Name	Traffic Device	Direction Controlled
0618	S 4TH ST / VINE ST	SS	EB
0618	S 4TH ST / VINE ST	SS	WB
0619	S 3RD ST / VINE ST	SS	EB
0619	S 3RD ST / VINE ST	SS	WB
0620	S 2ND ST / VINE ST	SS	EB
0620	S 2ND ST / VINE ST	SS	WB
0623	S 2ND ST / ARCH ST	SS	EB
0623	S 2ND ST / ARCH ST	SS	WB
0624	S 3RD ST / ARCH ST	SS	EB
0624	S 3RD ST / ARCH ST	SS	WB
0625	S 4TH ST / ARCH ST	SS	3NB
0625	S 4TH ST / ARCH ST	SS	3SB
0626	S 4TH ST / PINE ST	SS	EB
0626	S 4TH ST / PINE ST	SS	WB
0627	S 3RD ST / PINE ST	SS	EB
0627	S 3RD ST / PINE ST	SS	WB
0628	S 2ND ST / PINE ST	SS	EB
0628	S 2ND ST / PINE ST	SS	WB
0630	CLEVELAND TERR/PENNSYLVANIA ST	SS	NB
0631	S 24TH ST / HEBBELN DR	SS	NB
0631	S 24TH ST / HEBBELN DR	SS	SB
0632	S 23RD ST / HEBBELN DR	SS	NB
0633	S 22ND ST / HEBBELN DR	SS	EB
0636	S 24TH ST / VILAS ST	SS	SB
0637	S 23RD ST / VILAS ST	SS	NBEB
0637	S 23RD ST / VILAS ST	SS	SBWB
0638	S 22ND TERR / VILAS ST	SS	SB
0639	S 22ND ST / VILAS ST	SS	EB
0639	S 22ND ST / VILAS ST	SS	NB
0639	S 22ND ST / VILAS ST	SS	SB
0639	S 22ND ST / VILAS ST	SS	WB
0643	CAMBRIDGE ST / THORNTON ST	SS	NB
0643	CAMBRIDGE ST / THORNTON ST	SS	SB
0644	S 19TH ST / THORNTON ST	SS	NB
0645	S 18TH ST / THORNTON ST	SS	SB
0646	S 18TH ST / RIDGE RD	SS	EB
0646	S 18TH ST / RIDGE RD	SS	WB
0647	S 17TH TERR / THORNTON ST	SS	NB
0649	S 17TH ST / MARION ST	SS	EB
0650	S 17TH TERR / MARION ST	SS	WB

City of Leavenworth, KS Traffic Control Device Inventory, August 9, 2018

Intersection Number	Intersection Name	Traffic Device	Direction Controlled
0651	S 17TH ST / EVERGREEN ST	SS	EB
0652	S 17TH TERR / EVERGREEN ST	SS	NB
0652	S 17TH TERR / EVERGREEN ST	SS	SB
0653	CAMBRIDGE ST / EVERGREEN ST	SS	NB
0654	S 19TH TERR / EVERGREEN ST	SS	WB
0655	S 20TH ST / S19TH TERR	SS	WB
0658	S 20TH ST VILAS ST	TL	2EB 1 SB
0658	S 20TH ST VILAS ST	TL	2WB
0658	S 20TH ST VILAS ST	TL	3NB
0658	S 20TH ST VILAS ST	TL	3SB
0660	S 17TH ST / VILAS ST	SS	SB
0661	S 16TH TERR / VILAS ST	SS	SB
0662	S 16TH ST / VILAS ST	SS	NB
0662	S 16TH ST / VILAS ST	SS	SB
0663	FOLSOM ST / VILAS ST	SS	NB
0663	FOLSOM ST / VILAS ST	SS	SB
0664	S 16TH ST / HOLMAN ST	SS	EB
0665	N 6TH ST / DELAWARE ST	SS	EB
0665	N 6TH ST / DELAWARE ST	SS	NB
0665	N 6TH ST / DELAWARE ST	SS	SB
0666	FRANCIS AVE / VILAS ST	SS	NB
0666	FRANCIS AVE / VILAS ST	SS	SB
0667	S 14TH ST / VILAS ST	SS	NB
0667	S 14TH ST / VILAS ST	SS	SB
0668	SANTA FE ST / FRANCIS CT	SS	EB
0669	S 15TH ST / SANTA FE ST	SS	EB
0669	S 15TH ST / SANTA FE ST	SS	WB
0670	SANTA FE ST / FOLSOM ST	SS	NB
0671	S 16TH ST / SANTA FE ST	SS	WB
0672	S 15TH ST / JEANNE CT	SS	WB
0675	S 15TH ST / MARION ST	SS	WB
0678	VALHALLA PL / VILAS ST	SS	SB
0679	S 13TH ST / VILAS ST	SS	NB
0680	WESTWOOD DR / VILAS ST	SS	SB
0681	GRAND AVE / VILAS ST	SS	SB
0682	10TH AVE / VILAS ST	SS	EB
0682	10TH AVE / VILAS ST	SS	WB
0683	10TH AVE / HOLMAN ST	SS	EB
0684	10TH AVE / LIMIT ST	TL	2EB
0684	10TH AVE / LIMIT ST	TL	2NB

City of Leavenworth, KS Traffic Control Device Inventory, August 9, 2018

Intersection Number	Intersection Name	Traffic Device	Direction Controlled
0684	10TH AVE / LIMIT ST	TL	2SB
0684	10TH AVE / LIMIT ST	TL	2WB
0685	LIMIT ST / MEADOW RD	SS	NB
0686	GRAND AVE / LIMIT ST	SS	NB
0687	NEW LAWRENCE RD / LIMIT ST	SS	NB
0688	S 13TH ST / HOLMAN ST	SS	SB
0689	S 14TH ST / HOLMAN ST	SS	WB
0690	S 14TH ST / LIMIT ST	SS	NB
0690	S 14TH ST / LIMIT ST	SS	SB
0691	FRANCIS AVE / LIMIT ST	SS	SB
0692	S 15TH ST / LIMIT ST	SS	EB
0692	S 15TH ST / LIMIT ST	SS	WB
0693	FOLSOM ST / LIMIT ST	SS	SB
0694	S 16TH ST / LIMIT ST	SS	SB
0695	S 20TH ST / LIMIT ST	SS	EB
0695	S 20TH ST / LIMIT ST	SS	WB
0696	SOMERSET DR / LIMIT ST	SS	NB
0698	WESTWOOD DR / SANTA FE ST	SS	EB
0698	WESTWOOD DR / SANTA FE ST	SS	WB
0699	GRAND AV / SANTA FE ST	SS	EB
0700	10TH AVE / SANTA FE ST	SS	WB
0701	10TH AVE / SHERMAN ST	SS	EB
0702	KINGMAN ST / SHERMAN ST	SS	SB
0703	GRAND AVE / SHERMAN ST	SS	EB
0703	GRAND AVE / SHERMAN ST	SS	WB
0705	10TH AVE / MARION ST	SS	EB
0705	10TH AVE / MARION ST	SS	WB
0707	GRAND AVE / MARION ST	SS	WB
0708	10TH AVE / THORNTON ST	SS	WB
0709	10TH AVE / HALDERMAN ST	SS	EB
0709	10TH AVE / HALDERMAN ST	SS	WB
0710	GRAND AVE / HALDERMAN ST	SS	SB
0711	KLEMP ST / HALDERMAN ST	SS	SB
0718	WESTWOOD DR / FOREST LN (N)	SS	WB
0722	S 11TH ST / MICHIGAN ST	SS	NB
0722	S 11TH ST / MICHIGAN ST	SS	SB
0723	GRAND AV / MICHIGAN ST	SS	WB
0724	S 11TH ST / PENNSYLVANIA ST	SS	NB
0724	S 11TH ST / PENNSYLVANIA ST	SS	SB
0725	GRAND AVE / PENNSYLVANIA ST	SS	NB

City of Leavenworth, KS Traffic Control Device Inventory, August 9, 2018

Intersection Number	Intersection Name	Traffic Device	Direction Controlled
0725	GRAND AVE / PENNSYLVANIA ST	SS	SB
0726	KLEMP ST / PENNSYLVANIA ST	SS	WB
0727	KLEMP ST / SOUTH ST	SS	WB
0728	GRAND AV / SOUTH ST	SS	NB
0728	GRAND AV / SOUTH ST	SS	SB
0729	S 11TH ST / SOUTH ST	SS	SB
0730	10TH AVE / SOUTH ST	SS	EB
0736	MONTEZUMA ST/ REES ST	SS	NB
0737	ARTHUR ST / S BROADWAY ST	SS	WB
0739	CLEVELAND TERR / REES ST	SS	NB
0739	CLEVELAND TERR / REES ST	SS	SB
0740	S BROADWAY ST / REES ST	SS	EB
0740	LAWRENCE AVE / HALDERMAN ST	SS	EB
0740	S BROADWAY ST / REES ST	SS	WB
0742	GIRARD ST THORNTON ST	SS	NB
0742	GIRARD ST THORNTON ST	SS	SB
0743	GIRARD ST / MARION ST	SS	NB
0743	GIRARD ST / MARION ST	SS	SB
0744	SPRING GARDEN RD/MARION ST	SS	EB
0744	SPRING GARDEN RD/MARION ST	SS	WB
0745	SPRING GARDEN RD/THORNTON ST	SS	NB
0746	GARLAND ST / THORNTON ST	SS	NB
0747	GARLAND ST / MARION ST	SS	EB
0748	MONTEZUMA ST/THORNTON ST	SS	SB
0749	S BROADWAY ST/THORNTON ST	SS	SB
0751	CLEVELAND TER / GARFIELD ST	SS	SB
0752	THORNTON ST / MAPLE AVE	SS	NB
0752	THORNTON ST / MAPLE AVE	SS	SB
0755	W 7TH ST / REES ST	SS	NB
0756	5TH AVE / REES ST	SS	EB
0757	5TH AVE / DONIPHAN ST	SS	EB
0758	5TH AVE / THORNTON ST	SS	SB
0759	4TH AVE / THORNTON ST	SS	NB
0759	4TH AVE / THORNTON ST	SS	SB
0760	2ND AVE / THORNTON ST	TL	3NB 1EB
0760	2ND AVE / THORNTON ST	TL	3SB 1WB
0760	2ND AVE / THORNTON ST	TL	EB
0760	2ND AVE / THORNTON ST	TL	WB
0761	2ND AVE / BUTTINGER PL	SS	WB
0762	2ND AVE / DONIPHAN ST	SS	EB

City of Leavenworth, KS Traffic Control Device Inventory, August 9, 2018

Intersection Number	Intersection Name	Traffic Device	Direction Controlled
0764	2ND AVE / REES ST	SS	EB
0767	2ND AVE / SOUTH ST	SS	EB
0768	3RD AVE / SOUTH ST	SS	NB
0768	3RD AVE / SOUTH ST	SS	SB
0769	4TH AVE / SOUTH ST	SS	SB
0770	5TH AVE / SOUTH ST	SS	WB
0771	S 4TH ST / REES ST	SS	EB
0772	S 5TH ST / REES ST	SS	WB
0773	S 5TH ST / REASER ST	SS	EB
0774	S 4TH ST / APACHE ST	SS	EB
0775	ROSE ST / APACHE ST	SS	NB
0775	ROSE ST / APACHE ST	SS	SB
0776	S 5TH ST / BUTTINGER PL	SS	EB
0776	S 5TH ST / BUTTINGER PL	SS	WB
0776	S 5TH ST / BUTTINGER PL	SS	WB
0777	S 4TH ST / THORNTON ST	SS	EB
0778	ROSE ST / THORNTON ST	Y	SB
0779	S 5TH ST / THORNTON ST	SS	EB
0779	S 5TH ST / THORNTON ST	SS	NB
0779	S 5TH ST / THORNTON ST	SS	SB
0779	S 5TH ST / THORNTON ST	SS	WB
0780	S 4TH ST / MARION ST	TL	1SB 1EB
0780	S 4TH ST / MARION ST	TL	1WB 1NB
0780	S 4TH ST / MARION ST	TL	2NB 1 EB
0780	S 4TH ST / MARION ST	TL	2SB 1 WB
0781	ROSE ST / MARION ST	SS	NB
0782	S 5TH ST / MARION ST	SS	EB
0782	S 5TH ST / MARION ST	SS	WB
0783	S 4TH ST / EVERGREEN ST	SS	EB
0784	ROSE ST / EVERGREEN ST	SS	SB
0786	2ND AVE MARION ST	SS	WB
0787	S 4TH ST / SANTA FE ST	SS	WB
0788	S 4TH ST / SHERIDAN AVE	SS	EB
0788	S 4TH ST / SHERIDAN AVE	SS	WB
0789	S 4TH ST / VILAS ST	SS	EB
0789	S 4TH ST / VILAS ST	SS	WB
0790	2ND AVE / EVERGREEN ST	SS	EB
0791	2ND AVE / SHERMAN ST	SS	EB
0792	2ND AVE / SANTA FE ST	SS	EB
0792	2ND AVE / SANTA FE ST	SS	WB

City of Leavenworth, KS Traffic Control Device Inventory, August 9, 2018

Intersection Number	Intersection Name	Traffic Device	Direction Controlled
0793	2ND AVE / SHERIDAN ST	SS	WB
0794	2ND AVE / VILAS ST	SS	WB
0795	2ND AV / LIMIT ST	TL	NB
0795	2ND AV / LIMIT ST	TL	SB
0795	2ND AV / LIMIT ST	TL	SBNB
0795	2ND AV / LIMIT ST	TL	WB
0796	3RD AVE / SANTA FE ST	SS	NB
0796	3RD AVE / SANTA FE ST	SS	SB
0797	3RD AVE / SHERMAN ST	SS	EB
0797	3RD AVE / SHERMAN ST	SS	WB
0798	3RD AVE / EVERGREEN ST	SS	NB
0799	4TH AVE / MARION ST	SS	EB
0799		SS	WB
0800	4TH AVE / EVERGREEN ST (E)	SS	SB
0801	4TH AVE / EVERGREEN ST (W)	SS	NB
0803	MAPLE AVE / MARION ST	SS	WB
0804	4TH AVE / SHERMAN ST	SS	WB
0805	4TH AVE / SANTA FE ST	SS	NB
0805	4TH AVE / SANTA FE ST	SS	SB
0806	MAPLE AVE / SANTA FE ST	SS	EB
0806	MAPLE AVE / SANTA FE ST	SS	WB
0810	OLDE CREEK CT / SANTA FE ST	SS	NB
0811	BROADWAY TERR / SANTA FE ST	SS	NB
0812	BROADWAY TERR / VILAS ST	SS	EB
0813	LIMIT ST / SHRINE PARK RD	TL	1NB
0813	LIMIT ST / SHRINE PARK RD	TL	1SB
0813	LIMIT ST / SHRINE PARK RD	TL	2EB 1SB
0813	LIMIT ST / SHRINE PARK RD	TL	2WB 1SB
0814	LIMIT ST / VIRGINIA CIR	SS	NB
0815	BROADWAY TERR / LIMIT ST	SS	SB
0816	LIMIT ST / GARLAND ST (E)	SS	SB
0817	LIMIT ST / GARLAND ST (W)	SS	NB
0818	SPRING GARDEN RD/ LIMIT ST	SS	NB
0818	SPRING GARDEN RD/ LIMIT ST	SS	SB
0819	GIRARD ST / LIMIT ST	SS	SB
0820	GARLAND ST / VILAS ST	SS	NB
0820	GARLAND ST / VILAS ST	SS	SB
0821	GARLAND ST / SANTA FE ST	SS	NB
0821	GARLAND ST / SANTA FE ST	SS	SB
0822	SPRING GARDEN RD/SANTA FE ST	SS	NB

City of Leavenworth, KS Traffic Control Device Inventory, August 9, 2018

Intersection Number	Intersection Name	Traffic Device	Direction Controlled
0822	SPRING GARDEN RD/SANTA FE ST	SS	SB
0823	SPRING GARDEN RD/ VILAS ST	SS	NB
0823	SPRING GARDEN RD/ VILAS ST	SS	SB
0824	GIRARD ST / VILAS ST	SS	NB
0824	GIRARD ST / VILAS ST	SS	SB
0825	GIRARD ST / SANTA FE ST	SS	NB
0825	GIRARD ST / SANTA FE ST	SS	SB
0826	HUGHES RD / LIMIT ST	TL	1EB 1NB
0826	HUGHES RD / LIMIT ST	TL	1SB
0826	HUGHES RD / LIMIT ST	TL	3EB 1SB
0826	HUGHES RD / LIMIT ST	TL	3WB
0827	STATE ST / LOGAN ST	SS	WB
0828	STATE ST / VILAS ST	SS	WB
0830	S 4TH ST / LOGAN ST	SS	EB
0830	S 4TH ST / LOGAN ST	SS	WB
0831	S 4TH ST / LIMIT ST	TL	2EB 1SB
0831	S 4TH ST / LIMIT ST	TL	2WB 1NB
0831	S 4TH ST / LIMIT ST	TL	3NB
0831	S 4TH ST / LIMIT ST	TL	3SB
0832	LIMIT ST / TRAILHEAD DR	SS	NB
0833	S 2ND ST / LIMIT ST	SS	SB
0834	LIMIT ST / MARTIN LUTHER KING DR	SS	NB
0835	RALPH BUNCHE DR / LIMIT ST	SS	NB
0836	WILSON AVE / LIMIT ST	SS	NB
0836	WILSON AVE / LIMIT ST	SS	SB
0837	LIMIT ST / HOME PL	SS	EB
0838	HOME PL / LOGAN ST	SS	EB
0839	WILSON AVE / LOGAN ST	SS	EB
0839	WILSON AVE / LOGAN ST	SS	WB
0840	WILSON AVE / VILAS ST	SS	EB
0840	WILSON AVE / VILAS ST	SS	WB
0841	WILSON AVE / SHERIDAN ST	SS	EB
0841	WILSON AVE / SHERIDAN ST	SS	WB
0842	S 1ST ST / SHERIDAN ST	SS	EB
0842	S 1ST ST / SHERIDAN ST	SS	WB
0843	S 1ST ST / VILAS ST	SS	EB
0843	S 1ST ST / VILAS ST	SS	WB
0844	S 1ST ST / LOGAN ST	SS	EB
0844	S 1ST ST / LOGAN ST	SS	WB
0845	S 1ST ST / LIMIT ST	SS	SB

City of Leavenworth, KS Traffic Control Device Inventory, August 9, 2018

Intersection Number	Intersection Name	Traffic Device	Direction Controlled
0849	WILSON AVE / SANTA FE ST	SS	EB
0849	WILSON AVE / SANTA FE ST	SS	WB
0850	S 1ST ST / SANTA FE ST	SS	EB
0850	S 1ST ST / SANTA FE ST	SS	WB
0854	S 1ST ST / MARION ST	SS	NB
0855	S 2ND ST / MARION ST	SS	SB
0857	SOMERSET DR / SOMERSET TERR	SS	WB
0859	S 20TH ST / TONGANOSSIE DR	SS	NBEB
0859	S 20TH ST / TONGANOSSIE DR	SS	SBWB
0860	MICHALS RD / TONGANOSSIE DR	SS	SB
0861	MICHALS RD / STONEWALL CT	SS	NB
0862	MICHALS RD / CLAYTON DR	SS	NB
0863	MICHALS RD / RICHMOND DR	SS	NB
0864	RICHMOND DR / SUMTER CT	SS	EB
0864	RICHMOND DR / SUMTER CT	SS	WB
0866	MAGNOLIA DR / RICHMOND DR	SS	WB
0867	MAGNOLIA DR / LEE CT	SS	SB
0869	LEXINGTON CT / MAGNOLIA DR	SS	SB
0870	MAGNOLIA DR / TONGANOSSIE DR	SS	EB
0871	SHENANDOAH DR / TONGANOSSIE DR	SS	EB
0872	SHENANDOAH DR / CLAYTON CT	SS	NB
0873	SHENANDOAH DR / DISSIE DR	SS	NB
0875	RICHMOND DR / LINCOLN CT	SS	WB
0876	RICHMOND DR / SHENANDOAH DR	SS	NB
0876	RICHMOND DR / SHENANDOAH DR	SS	SB
0877	SHENANDOAH DR / GETTYSBURG DR	SS	NB
0878	GETTYSBURG DR / CADES CV	SS	WB
0879	GETTYSBURG DR / RICHMOND DR	SS	NBEB
0879	GETTYSBURG DR / RICHMOND DR	SS	SBWB
0880	GETTYSBURG DR / CAVALRY CT	SS	NB
0881	S 20TH ST / ESTATES DR	SS	EB
0882	S 21ST ST / ESTATES DR	SS	WB
0884	S 21ST ST / S 22ND ST	SS	NB
0885	S 21ST ST / RIDGEVIEW DR	SS	EB
0886	S 21ST ST / CEDAR RIDGE DR	SS	EB
0887	TONGANOSSIE DR / CANDLEWOOD DR	SS	NB
0888	TONGANOSSIE DR / SUMMIT DR	SS	SB
0889	TONGANOSSIE DR / GATEWOOD ST	SS	NB
0890	GATEWOOD ST / TUDOR DR	SS	EB
0891	TUDOR DR / CANDLEWOOD DR	SS	WB

City of Leavenworth, KS Traffic Control Device Inventory, August 9, 2018

Intersection Number	Intersection Name	Traffic Device	Direction Controlled
0892	WINCHESTER DR / CANDLEWOOD DR	SS	NBEB
0892	WINCHESTER DR / CANDLEWOOD DR	SS	SBWB
0894	REMINGTON LN / CANDLEWOOD DR	SS	WB
0895	REMINGTON LN / REMINGTON CT	SS	NB
0896	REMINGTON LN / WINCHESTER DR	SS	EB
0898	S 14TH ST / INDEPENDENCE CT	SS	EB
0898	S 14TH ST / INDEPENDENCE CT	SS	WB
0899	S 14TH ST / REVOLUTIONARY CT	SS	WB
0900	MILITIA CT / REVOLUTIONARY CT	SS	SB
0901	NEW LAWRENCE RD / TANGLEWOOD ST	SS	EB
0901	NEW LAWRENCE RD / TANGLEWOOD ST	SS	WB
0902	GRAND AVE / TANGLEWOOD ST	SS	EB
0903	10TH AVE / MEADOW LN	SS	EB
0904	MEADOW RD / MEADOW LN	SS	WB
0906	GRAND AVE / WILDWOOD ST	SS	EB
0907	NEW LAWRENCE RD / WILDWOOD ST	SS	EB
0907	NEW LAWRENCE RD / WILDWOOD ST	SS	WB
0908	WILDWOOD ST / FOXHILL ST	SS	NB
0909	10TH AVE / GATEWOOD ST	TL	2EB
0909	10TH AVE / GATEWOOD ST	TL	2NB
0909	10TH AVE / GATEWOOD ST	TL	2SB
0909	10TH AVE / GATEWOOD ST	TL	2WB
0910	NEW LAWRENCE RD / GATEWOOD ST	SS	WB
0911	S 14TH ST / NEW LAWRENCE RD	SS	SB
0912	S 20TH ST / NEW LAWRENCE RD	SS	WB
0913	10TH AVE / JOSELA CT	SS	WB
0914	10TH AVE / WELLINGTON DR	SS	EB
0916	WELLINGTON DR / GRAND AVE	SS	NB
0917	WELLINGTON DR / NEWMAN ST	Y	EB
0920	GRAND AVE / WALLIS LN	SS	NB
0920	GRAND AVE / WALLIS LN	SS	SB
0922	IRONWOOD DR / TAMARISK DR	SS	EB
0923	IRONWOOD DR / IRONWOOD CT	SS	EB
0924	WALLIS LN / IRONWOOD DR	SS	NB
0926	10TH AVE / FOREST HILLS LN	SS	EB
0927	10TH AVE / WALLIS LN	SS	EB
0928	10TH AVE / MUNCIE RD	SS	WB
0929	10TH AVE / PARK AVE	SS	WB
0930	10TH AVE / LEWIS DR	SS	WB
0931	10TH AVE / EISENHOWER RD	TL	2NB

City of Leavenworth, KS Traffic Control Device Inventory, August 9, 2018

Intersection Number	Intersection Name	Traffic Device	Direction Controlled
0931	10TH AVE / EISENHOWER RD	TL	3EB
0931	10TH AVE / EISENHOWER RD	TL	3SB
0931	10TH AVE / EISENHOWER RD	TL	3WB
0932	S 13TH ST / EISENHOWER RD	SS	SB
0933	S 20TH ST / EISENHOWER RD	SS	NB
0933	S 20TH ST / EISENHOWER RD	SS	SB
0934	BRANCHES WAY / EISENHOWER RD	SS	SB
0935	BIRCH ST / EISENHOWER RD	SS	SB
0936	BIRCH ST / COTTONWOOD ST	SS	NB
0936	BIRCH ST / COTTONWOOD ST	SS	SB
0937	COTTONWOOD ST / ALDER ST	SS	SB
0938	BRANCHES WAY / S 22ND ST	SS	NB
0939	S 22ND ST / S 22ND ST (S)	SS	EB
0941	S 22ND ST / ALDER ST	SS	EB
0942	S 22ND ST / BIRCH ST	SS	EB
0945	SPRING GARDEN RD/ MEADOW LN	Y	SB
0946	GARLAND ST / MEADOW LN	SS	SB
0958	MAPLE AVE/GODDARD CIR	SS	EB
0959	SHRINE PARK RD/VIRGINIA CIR	SS	EB
0960	SHRINE PARK RD / SILVERLEAF	SS	EB
0961	SHRINE PARK RD / GREENS RIDGE	SS	EB
0963	10TH AVE / BROOKSIDE ST	SS	WB
0970	SHRINE PARK RD / MCDONALD RD	SS	WB
0971	SHRINE PARK RD/VALLEY VIEW RD (N)	SS	WB
0972	SHRINE PARK RD / FAWN CREEK ST	SS	EB
0973	SHRINE PARK RD / DEERFIELD ST	SS	EB
0975	GARLAND ST / DEERFIELD ST	SS	WB
0978	VILLAGE ST / GARLAND ST	SS	SB
0981	MUNCIE RD / PARKWAY DR	SS	NB
0981	MUNCIE RD / PARKWAY DR	SS	SB
0985	PARK AVE / PARK LN	SS	EB
0985	MAPLE AVE/GODDARD CIR	SS	EB
0986	PARK LN / HIGHLAND DR	SS	WB
0987	MUNCIE RD / MUNCIE CT	SS	NB
0987	MUNCIE RD / MUNCIE CT	SS	SB
0988	GARLAND ST / MUNCIE RD	SS	SB
0989	BROADWAY TERR / MUNCIE RD	SS	SB
0991	HIGHLAND DR / EDGEHILL ST	SS	EB
0991	HIGHLAND DR / EDGEHILL ST	SS	WB
0993	PARK AVE / EDGEHILL ST	SS	EB

City of Leavenworth, KS Traffic Control Device Inventory, August 9, 2018

Intersection Number	Intersection Name	Traffic Device	Direction Controlled
0994	GLENVIEW ST / EDEHILL ST	SS	EB
0995	PARK LN / GLENVIEW ST	SS	WB
0996	HIGHLAND TERR / PARK LN	SS	WB
0997	HIGHLAND TERR / GARLAND ST	SS	NB
0998	HIGHLAND TERR /BROADWAY TERR	SS	NB
0999	HIGHLAND TERR / EDGEHILL ST	SS	EB
1000	LEWIS DR / PARKWAY DR	SS	SB
1002	SHRINE PARK RD / MUNCIE RD	SS	EB
1002	SHRINE PARK RD / MUNCIE RD	SS	WB
1003	SHRINE PARK RD / VALLEY VIEW RD (S)	SS	WB
1005	SHRINE PARK RD / SUMMIT RD (N)	SS	WB
1005	SHRINE PARK RD / SUMMIT RD (N)	SS	WB
1007	SHRINE PARK RD / EISENHOWER RD	TL	2NB
1007	SHRINE PARK RD / EISENHOWER RD	TL	2SB
1007	SHRINE PARK RD / EISENHOWER RD	TL	3EB
1007	SHRINE PARK RD / EISENHOWER RD	TL	3WB
1008	EISENHOWER RD / LAKEVIEW DR	SS	SB
1009	EISNEHOWER RD / HUGHES RD	SS	SB
1010	S 4TH ST / EISENHOWER RD	TL	1 SB 1 EB
1010	S 4TH ST / EISENHOWER RD	TL	1WB 1NB
1010	S 4TH ST / EISENHOWER RD	TL	2NB 1EB
1010	S 4TH ST / EISENHOWER RD	TL	3SB
1011	BREWER PL / COMMERCIAL ST	SS	EB
1012	BREWER PL / HIGHWAY TER	SS	WB
1013	MUNCIE RD / BREWER PL	SS	NB
1014	COMMERCIAL ST / COMMERCIAL PL	SS	SB
1015	MUNCIE RD / COMMERCIAL PL	SS	NB
1016	S 4TH ST / MUNCIE RD	TL	2EB
1016	S 4TH ST / MUNCIE RD	TL	2WB
1016	S 4TH ST / MUNCIE RD	TL	3NB
1016	S 4TH ST / MUNCIE RD	TL	3SB
1017	S 4TH ST / MUNCIE TERR	SS	EB
1018	S 4TH ST / COMMERCIAL ST	SS	WB
1019	MUNCIE RD / HUGHES RD	SS	EB
1019	MUNCIE RD / HUGHES RD	SS	WB
1020	HUGHES RD / PLEASANT AVE	SS	EB
1021	PLEASANT AVE / IOWA ST	SS	NB
1021	PLEASANT AVE / IOWA ST	SS	SB
1022	IOWA ST / NIPPER LN	SS	EB
1022	IOWA ST / NIPPER LN	SS	WB

City of Leavenworth, KS Traffic Control Device Inventory, August 9, 2018

Intersection Number	Intersection Name	Traffic Device	Direction Controlled
1023	HUGHES RD / MCDONALD RD	SS	EB
1025	MCDONALD RD / IOWA ST	SS	NB
1026	LAKEVIEW DR / MCDONALD RD	SS	NB
1026	LAKEVIEW DR / MCDONALD RD	SS	SB
1027	LAKEVIEW DR / PLEASANT AVE	SS	WB
1028	LAKEVIEW DR / MUNCIE RD	SS	NB
1028	LAKEVIEW DR / MUNCIE RD	SS	SB
1029	LAKEVIEW DR/ CEDAR CT	SS	WB
1030	LAKEVIEW DR / OREGON ST	SS	EB
1034	HUGHES RD / ST JOHN HOSPITAL	SS	WB
1035	HUGHES RD / CEDAR CT	SS	EB
1036	HUGHES RD / OREGON ST	SS	EB
1037	HUGHES RD / LV PLAZA	SS	WB
1038	HUGHES RD / IDAHO ST	SS	EB
1042	HUGHES RD / UTAH ST	SS	EB
1046	S 4TH ST / MONTANA CT	SS	WB
1047	IDAHO ST / FRONTAGE RD	SS	NB
1047	IDAHO ST / FRONTAGE RD	SS	SB
1048	S 4TH ST / IDAHO ST	TL	2EB
1048	S 4TH ST / IDAHO ST	TL	2WB
1048	S 4TH ST / IDAHO ST	TL	3NB
1048	S 4TH ST / IDAHO ST	TL	3SB 1WB
1049	MLK DR (S) / MLK DR (E)	SS	WB
1050	MLK DR / RALPH BUNCE DR (W)	SS	NB
1053	MLK DR / RALPH BUNCE DR (E)	SS	WB
1054	WILSON AVE / ASH ST	SS	EB
1055	FRONTAGE RD / ASH ST	SS	WB
1058	FRONTAGE RD / OREGON ST (S)	SS	EB
1059	FRONTAGE RD / OREGON ST (N)	SS	WB
1060	S 4TH ST / OREGON ST (N)	SS	WB
1062	S 4TH ST / ST JOHN HOSPITAL	SS	EB
1063	S 4TH ST / UNIVERSITY OF ST MARY DR	SS	EB
1065	S 4TH ST / VA ENTRANCE ON RAMP	Y	NB
1066	S 4TH ST / VA ENTRANCE	SS	WB
1068	S 4TH ST / SISTERS OF CHARITY DR	SS	EB
1471	MUNCIE RD / S VA ENTRANCE DR	SS	SB
1472	MUNCIE RD / VA CEMETARY ENTRANCE	SS	SB
1473	S 22ND ST / CO RD 12	SS	EB
1479	S 14TH ST / EISENHOWER RD	SS	SB
1480	WEST GLEN ST / NEW LAWRENCE RD	SS	NB

City of Leavenworth, KS Traffic Control Device Inventory, August 9, 2018

Intersection Number	Intersection Name	Traffic Device	Direction Controlled
1481	NEW LAWRENCE DR / SUNSET ST	SS	WB
1482	TALLGRASS ST / WEST GLEN DR	SS	NB
1483	SHADOW DR / SUNRISE ST	SS	NB
1483	SHADOW DR / SUNRISE ST	SS	SB
3076	FIRE STATION #2	TL	2NB
3076	FIRE STATION #2	TL	2WB
3077	FIRE STATION #3	TL	2NB
3077	FIRE STATION #3	TL	2SB
3079	FIRE STATION 1	TL	2NB
3079	FIRE STATION 1	TL	2SB
3079	FIRE STATION 1	TL	2WB